

## DESCRIPTION

The MAX13487/MAX13488 +3.3V/+5V Operation,  $\pm 15\text{kV}$  ESD-protected half-duplex, RS-485/RS-422-compatible transceivers feature one driver and one receiver. The MAX13487/ MAX13488 include a hot-swap capability to eliminate false transitions on the bus during power-up or live insertion.

The MAX13487/MAX13488 feature AutoDirection control. This architecture makes the devices ideal for applications, such as isolated RS-485 ports, where the driver input is used in conjunction with the driver-enable signal to drive the differential bus.

The MAX13487 features reduced slew-rate drivers that minimize EMI and reduce reflections caused by improperly terminated cables, allowing error-free transmission up to 500kbps. The MAX13488 driver slew rate is not limited, allowing transmit speeds up to 16Mbps.

The MAX13487/MAX13488 feature a 1/8-unit load receiver input impedance, allowing up to 256 transceivers on the bus. These devices are intended for half-duplex communications. All driver outputs are protected to  $\pm 15\text{kV}$  ESD using the Human Body Model. The MAX13487/MAX13488 are available in an 8-pin SO package. The devices operate over the extended  $-40^{\circ}\text{C}$  to  $+85^{\circ}\text{C}$  temperature range.

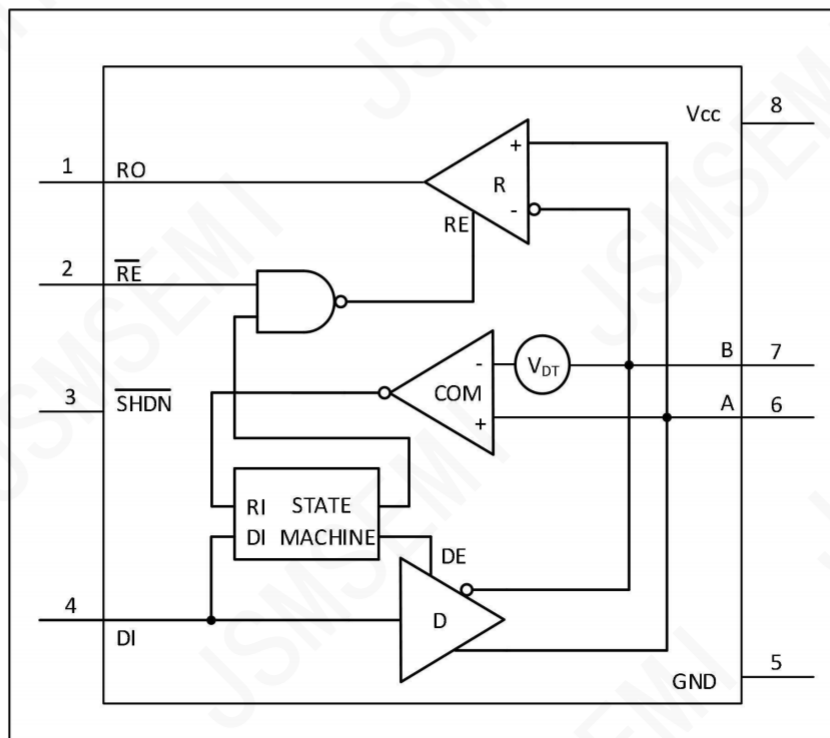
## FEATURES

- +3.3V/+5V Operation
- AutoDirection Enables Driver Automatically on Transmission
- Hot-Swappable for Telecom Applications
- Enhanced Slew-Rate Limiting Facilitates Error-Free Data Transmission (MAX13487)
- High-Speed Version (MAX13488) Allows for Transmission Speeds Up to 16Mbps
- Extended ESD Protection for RS-485 I/O Pins  $\pm 15\text{kV}$  Human Body Model
- 1/8-Unit Load, Allowing Up to 256 Transceivers on the Bus
- 8-Pin SO Package

## APPLICATIONS

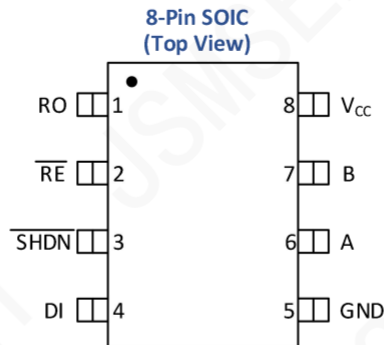
- Isolated RS-485 Interfaces
- Utility Meters
- Industrial Controls
- Industrial Motor Drives
- Automated HVAC Systems

## MAX13487/MAX13488 Block Diagram





## Pin Configuration and Functions



### Pin Functions

PIN	Name	FUNCTION
1	RO	Receiver Output. When receiver is enabled and $V(A) - V(B) > -50\text{mV}$ , RO is high. If $V(A) - V(B) < -200\text{mV}$ , RO is low.
2	$\overline{\text{RE}}$	Receiver Output Enable. Drive $\overline{\text{RE}}$ low to enable the RO. Drive $\overline{\text{RE}}$ high to let the AutoDirection circuit control the receiver. $\overline{\text{RE}}$ is a hot-swap input (see the <i>Hot-Swap Capability</i> section for more details).
3	$\overline{\text{SHDN}}$	Shutdown. Drive $\overline{\text{SHDN}}$ high to let the device operate in normal operation. Drive $\overline{\text{SHDN}}$ low to put the part in shutdown.
4	DI	Driver Input. Drive DI low to force noninverting output low and inverting output high. Drive DI high to force noninverting output high and inverting output low. DI is an input to the internal state machine that automatically enables and disables the driver. See the <i>Function Tables</i> and <i>General Description</i> for more information. DI is a hot-swap input (see the <i>Hot-Swap Capability</i> section for more details).
5	GND	Ground
6	A	Noninverting Receiver Input and Noninverting Driver Output
7	B	Inverting Receiver Input and Inverting Driver Output
8	V <sub>CC</sub>	Positive Supply, $V_{CC} = +3.3\text{V} \pm 5\% / +5\text{V} \pm 5\%$ . Bypass $V_{CC}$ to GND with a $0.1\mu\text{F}$ capacitor.

## Specifications

### Absolute Maximum Ratings

 See Note<sup>(1)</sup>

Parameter	Description	Value	Unit
$V_{CC}$	Supply Voltage	+6	V
$\overline{SHDN}$ , $\overline{RE}$ , DI	Control input voltage	-0.3 to +6	V
A, B	Driver output voltage	-8 to +13	V
$T_o$	Operating Temperature Range	-40 to +85	°C
$T_j$	Junction Temperature	+150	°C
$T_{stg}$	Storage Temperature Range	-65 to +150	°C

(1) Stresses beyond those listed under "Absolute Maximum Ratings" may cause permanent damage to the device.

### Electrical Characteristics

 ( $V_{CC} = +5V \pm 5\%$ ,  $T_A = T_{MIN}$  to  $T_{MAX}$ , unless otherwise noted. Typical values are at  $V_{CC} = +5V$  and  $T_A = +25^\circ C$ .) (Note 1)

PARAMETER	SYMBOL	CONDITIONS	MIN	TYP	MAX	UNITS
<b>DRIVER</b>						
Differential Driver Output	$V_{OD}$	$R_{DIFF} = 100\Omega$ , <a href="#">Figure 1</a>	2.5	3.3V	$V_{CC}$	V
		$R_{DIFF} = 54\Omega$ , <a href="#">Figure 1</a>	2.0	2.6V		
		$R_{DIFF} = 100\Omega, V_{CC} = 3.3V$ , <a href="#">Figure 1</a>	1.5	2.0V		
		$R_{DIFF} = 54\Omega, V_{CC} = 3.3V$ , <a href="#">Figure 1</a>	1.0	1.6V		
		No load			$V_{CC}$	
Driver Common-Mode Output Voltage	$V_{OC}$	$R_L = 100\Omega$ or $54\Omega$ , <a href="#">Figure 1</a>		$V_{CC}/2$	3	V
Driver Disable Threshold	$V_{DT}$	<a href="#">Figure 2</a> (Note 2)	+0.6		+1	V
Input-High Voltage	$V_{IH}$	DI, $\overline{SHDN}$ , $\overline{RE}$	2.0			V
Input-Low Voltage	$V_{IL}$	DI, $\overline{SHDN}$ , $\overline{RE}$			0.8	V
Input Current	$I_{IN}$	DI, $\overline{SHDN}$ , $\overline{RE}$			$\pm 1$	$\mu A$
Driver Short-Circuit Output Current	$I_{OSD}$	$0V \leq V_{OUT} \leq +12V$	+50		+250	mA
		$-7V \leq V_{OUT} \leq 0V$	-250		-50	
<b>RECEIVER</b>						
Input Current (A and B)	$I_{A, B}$	DI = $V_{CC}$ , $V_{CC} = GND$ or +5V	$V_{IN} = +12V$		250	$\mu A$
			$V_{IN} = -7V$	-200		
Receiver Differential Threshold Voltage	$V_{TH}$	$-7V \leq V_{CM} \leq +12V$	-200		-50	mV
Receiver Input Hysteresis	$\Delta V_{TH}$	$V_A + V_B = 0V$		25		mV
Output-High Voltage	$V_{OH}$	$I_O = -1.6mA$ , $V_A - V_B > V_{TH}$	$V_{CC} - 1.5$			V
Output-Low Voltage	$V_{OL}$	$I_O = 1mA$ , $V_A - V_B < -V_{TH}$			0.4	V
Tri-State Output Current at Receiver	$I_{OZR}$	$0V \leq V_O \leq V_{CC}$			$\pm 1$	$\mu A$
Receiver Input Resistance	$R_{IN}$	$-7V \leq V_{CM} \leq +12V$	96			k $\Omega$
Receiver Output Short-Circuit Current	$I_{OSR}$	$0V \leq V_{RO} \leq V_{CC}$	$\pm 7$		$\pm 95$	mA

POWER SUPPLY						
Supply Voltage	V <sub>CC</sub>		4.75		5.25	V
Supply Current	I <sub>CC</sub>	$\overline{\text{SHDN}} = 1, \overline{\text{RE}} = 0, \text{no load}$		0.6	2.0	mA
Supply Voltage	V <sub>CC</sub>		3.15		3.45	V
Supply Current	I <sub>CC</sub>	$\overline{\text{SHDN}} = 1, \overline{\text{RE}} = 0, \text{no load}$		0.47	1.0	mA
Shutdown Supply Current	I <sub>SHDN</sub>	$\overline{\text{SHDN}} = 0$		2	10	μA
ESD PROTECTION						
ESD Protection (A, B)		Air Gap Discharge IEC 61000-4-2		±15		kV
		Human Body Model		±15		
ESD Protection (All Other Pins)		Human Body Model		±4		kV

### Switching Characteristics—MAX13487

(V<sub>CC</sub> = +5V ±5%, T<sub>A</sub> = T<sub>MIN</sub> to T<sub>MAX</sub>, unless otherwise noted. Typical values are at V<sub>CC</sub> = +5V and T<sub>A</sub> = +25°C.)

PARAMETER	SYMBOL	CONDITIONS	MIN	TYP	MAX	UNITS
DRIVER						
Driver Propagation Delay	t <sub>DPLH</sub>	R <sub>L</sub> = 110Ω, C <sub>L</sub> = 50pF, <a href="#">Figure 2</a> and <a href="#">3</a>	200		1000	ns
	t <sub>DPHL</sub>		200		1000	
Driver Differential Output Rise or Fall Time	t <sub>HL</sub>	R <sub>L</sub> = 110Ω, C <sub>L</sub> = 50pF, <a href="#">Figure 2</a> and <a href="#">3</a>	200		900	ns
	t <sub>LH</sub>		200		900	
Maximum Data Rate			500			kbps
Driver Disable Delay	t <sub>DDD</sub>	<a href="#">Figure 3</a>			2500	ns
Driver Enable from Shutdown to Output High	t <sub>DZH(SHDN)</sub>	<a href="#">Figure 4</a>			5.5	μs
Driver Enable from Shutdown to Output Low	t <sub>DZL(SHDN)</sub>	<a href="#">Figure 4</a>			5.5	μs
Time to Shutdown	t <sub>SHDN</sub>		50	340	700	ns
RECEIVER						
Receiver Propagation Delay	t <sub>RPLH</sub>	C <sub>L</sub> = 15pF, <a href="#">Figures 5</a> and <a href="#">6</a>			80	ns
	t <sub>RPHL</sub>				80	
Receiver Output Skew	t <sub>RSKEW</sub>	C <sub>L</sub> = 15pF, <a href="#">Figure 6</a>			13	ns
Maximum Data Rate			500			kbps
Receiver Enable to Output High	t <sub>RZH</sub>	<a href="#">Figure 7</a>			50	ns
Receiver Enable to Output Low	t <sub>RZL</sub>	<a href="#">Figure 7</a>			50	ns
Receiver Disable Time from High	t <sub>RHZ</sub>	<a href="#">Figure 7</a>			50	ns
Receiver Disable Time from Low	t <sub>RLZ</sub>	<a href="#">Figure 7</a>			50	ns
Receiver Enable from Shutdown to Output High	t <sub>RZH(SHDN)</sub>	<a href="#">Figure 8</a>			2200	ns
Receiver Enable from Shutdown to Output Low	t <sub>RZL(SHDN)</sub>	<a href="#">Figure 8</a>			2200	ns
Receiver Enable Delay	t <sub>RED</sub>	<a href="#">Figure 3</a>			70	ns
Time to Shutdown	t <sub>SHDN</sub>		50	340	700	ns

**Switching Characteristics—MAX13488**

 ( $V_{CC} = +5V \pm 5\%$ ,  $T_A = T_{MIN}$  to  $T_{MAX}$ , unless otherwise noted. Typical values are at  $V_{CC} = +5V$  and  $T_A = +25^\circ C$ .)

PARAMETER	SYMBOL	CONDITIONS	MIN	TYP	MAX	UNITS
<b>DRIVER</b>						
Driver Propagation Delay	$t_{DPLH}$	$R_L = 110\Omega$ , $C_L = 50pF$ , <a href="#">Figures 2 and 3</a>			50	ns
	$t_{DPHL}$				50	
Driver Differential Output Rise or Fall Time	$t_{HL}$	$R_L = 110\Omega$ , $C_L = 50pF$ , <a href="#">Figures 2 and 3</a>			15	ns
	$t_{LH}$				15	
Maximum Data Rate			16			Mbps
Driver Disable Delay	$t_{DDD}$	<a href="#">Figure 3</a>			70	ns
Driver Enable from Shutdown to Output High	$t_{DZH(SHDN)}$	<a href="#">Figure 4</a>			2.2	$\mu s$
Driver Enable from Shutdown to Output Low	$t_{DZL(SHDN)}$	<a href="#">Figure 4</a>			2.2	$\mu s$
Time to Shutdown	$t_{SHDN}$		50	340	700	ns
<b>RECEIVER</b>						
Receiver Propagation Delay	$t_{RPLH}$	$C_L = 15pF$ , <a href="#">Figures 5 and 6</a>			80	ns
	$t_{RPHL}$				80	
Receiver Output Skew	$t_{RSKEW}$	$C_L = 15pF$ , <a href="#">Figure 6</a>			13	ns
Maximum Data Rate			16			Mbps
Receiver Enable to Output High	$t_{RZH}$	<a href="#">Figure 7</a>			50	ns
Receiver Enable to Output Low	$t_{RZL}$	<a href="#">Figure 7</a>			50	ns
Receiver Disable Time from High	$t_{RHZ}$	<a href="#">Figure 7</a>			50	ns
Receiver Disable Time from Low	$t_{RLZ}$	<a href="#">Figure 7</a>			50	ns
Receiver Enable from Shutdown to Output High	$t_{RZH(SHDN)}$	<a href="#">Figure 8</a>			2200	ns
Receiver Enable from Shutdown to Output Low	$t_{RZL(SHDN)}$	<a href="#">Figure 8</a>			2200	ns
Receiver Enable Delay	$t_{RED}$	<a href="#">Figure 3</a>			70	ns
Time to Shutdown	$t_{SHDN}$		50	340	700	ns

**Note 1:** All currents into the device are positive. All currents out of the device are negative. All voltages referred to device ground, unless otherwise noted.

**Note 2:** This is a differential voltage from A to B that the driving device must see on the bus to disable its driver.

**Function Tables**

TRANSMITTING					
INPUTS			OUTPUTS		
$\overline{\text{SHDN}}$	DI	A-B > $V_{DT}$	ACTION	A	B
1	0	X	Turn driver ON	0	1
1	1	False	If driver was OFF, keep it OFF	HIGH IMPEDANCE	HIGH IMPEDANCE
1	1	False	If driver was ON, keep it ON	1	0
1	1	True	Turn driver OFF	HIGH IMPEDANCE	HIGH IMPEDANCE
0	X	X	X	SHUTDOWN	

RECEIVING					
INPUTS				OUTPUT	
$\overline{\text{SHDN}}$	$\overline{\text{RE}}$	A-B	DRIVER STATE	RECEIVER STATE	RO
1	0	$\geq -50\text{mV}$	X	ON	1
1	0	$\leq -200\text{mV}$	X	ON	0
1	1	X	ON	OFF	HIGH IMPEDANCE
1	1	$\geq -50\text{mV}$	OFF	ON	1
1	1	$\leq -200\text{mV}$	OFF	ON	0
0	X	X	X	X	SHUTDOWN

X = Don't care, shutdown mode, driver, and receiver outputs are in high impedance.

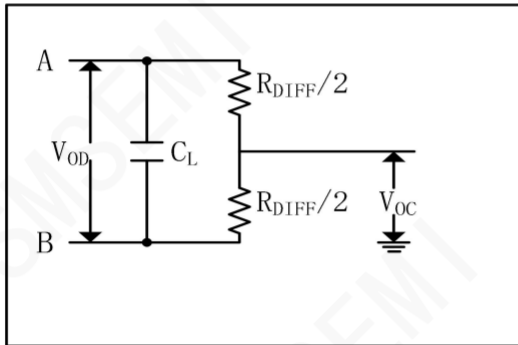
**Test Circuits and Waveforms**


Figure 1. Driver DC Test Load

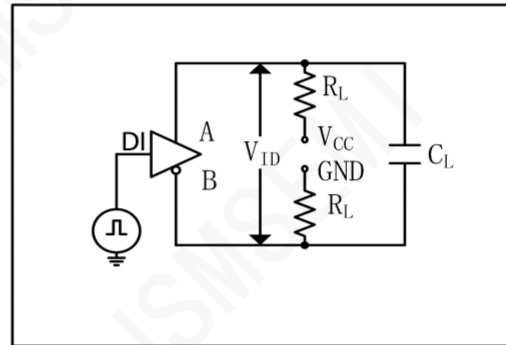


Figure 2. Driver-Timing Test Circuit

Test Circuits and Waveforms (continued)

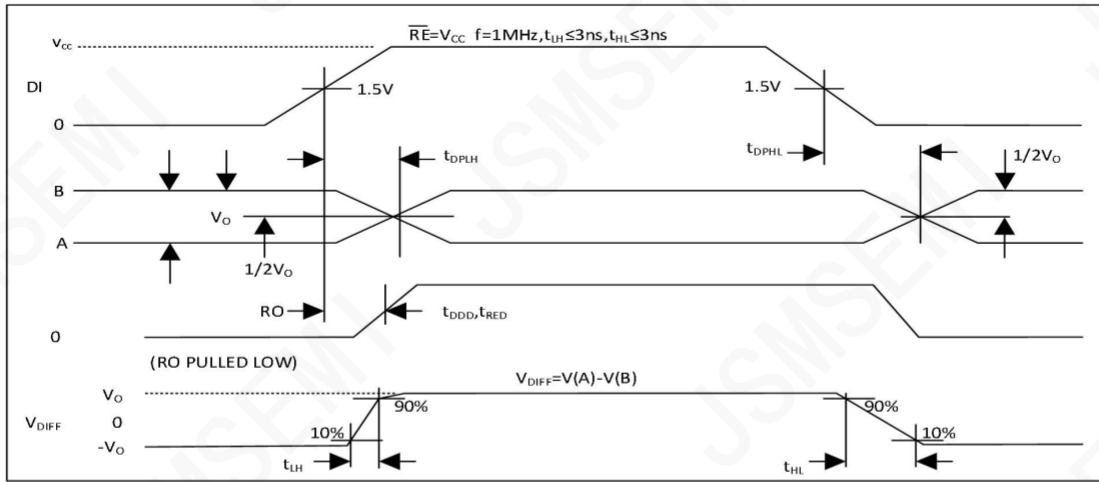


Figure 3. Driver Propagation Delays

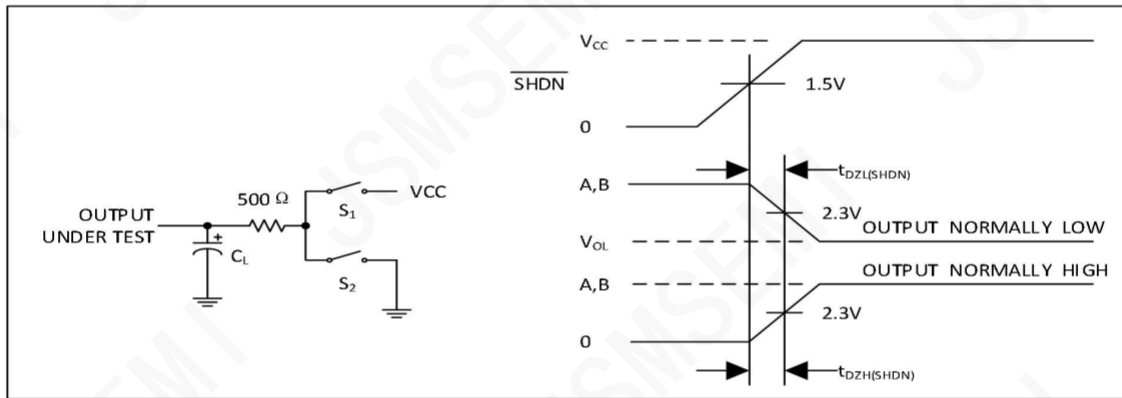


Figure 4. Driver Enable and Disable Times

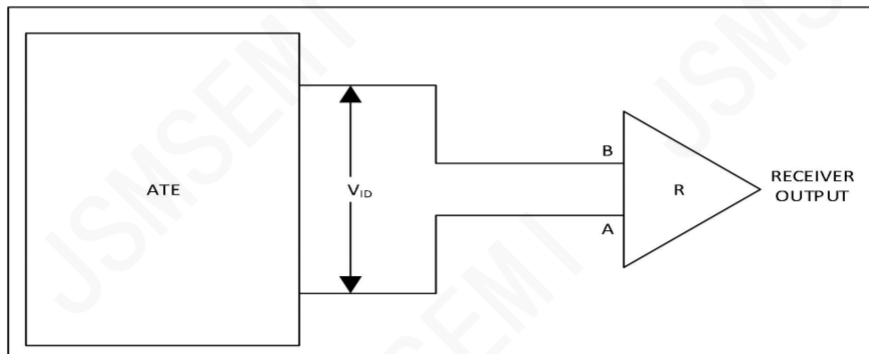


Figure 5. Receiver-Propagation-Delay Test Circuit

Test Circuits and Waveforms (continued)

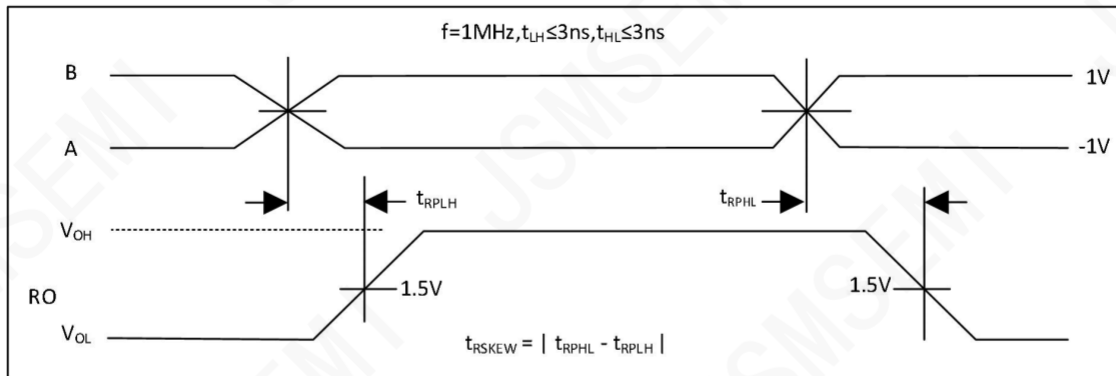


Figure 6. Receiver Propagation Delays

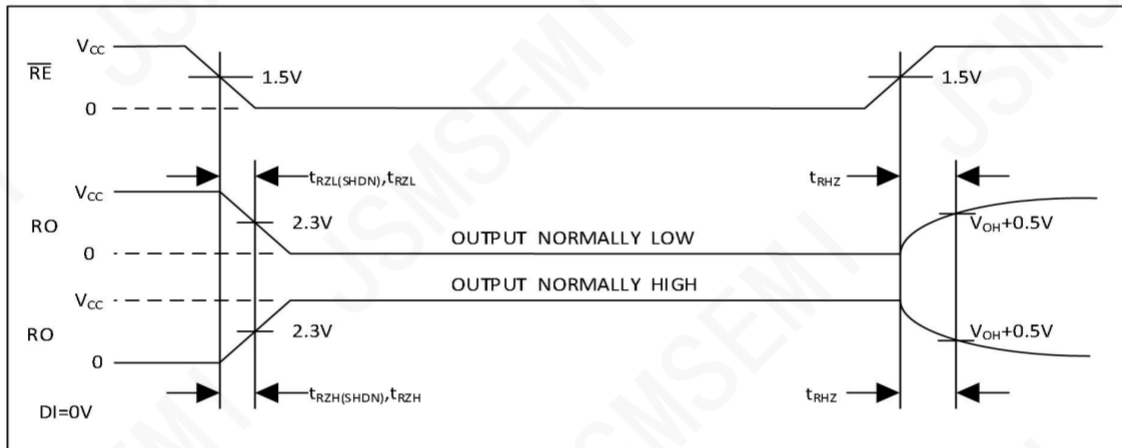


Figure 7. Receiver Enable and Disable Times

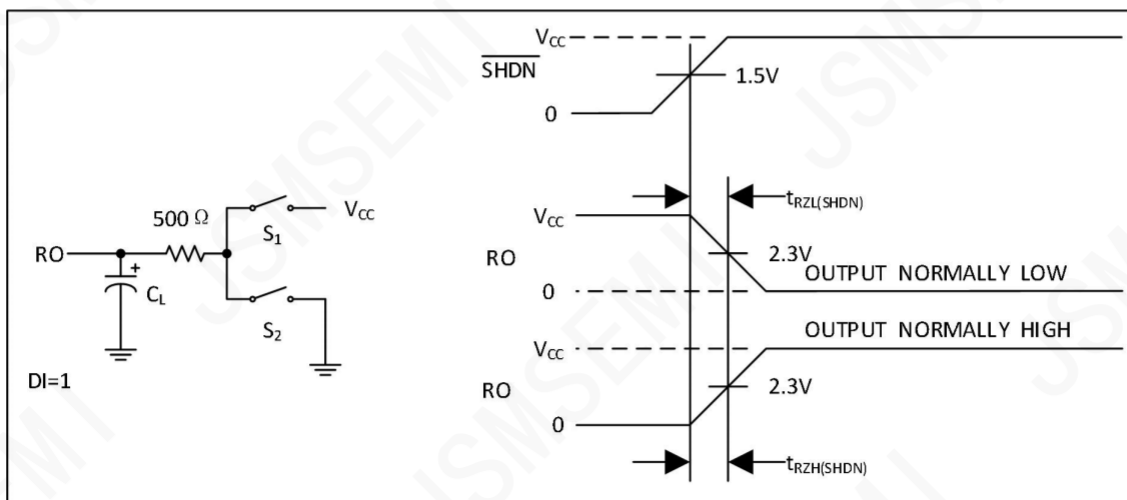


Figure 8. Receiver Enable Time from Shutdown

## Detailed Description

The MAX13487/MAX13488 half-duplex, high-speed transceivers for RS-485/RS-422 communication contain one driver and one receiver. The MAX13487/ MAX13488 feature a hot-swap capability allowing line insertion without erroneous data transfer (see the Hot-Swap Capability section). The MAX13487 features reduced slew-rate drivers that minimize EMI and reduce reflections caused by improperly terminated cables, allowing error-free transmission up to 500kbps. The MAX13488 driver slew rate is not limited, making data throughput of up to 16Mbps possible.

## AutoDirection Circuitry

Internal circuitry in the MAX13487/MAX13488, in conjunction with an external pullup resistor on A and pulldown resistor on B (see Typical Application Circuit), act to automatically disable or enable the driver and receiver to keep the bus in the correct state. This AutoDirection circuitry consists of a state machine and an additional receive comparator that determines whether this device is trying to drive the bus, or another node on the network is driving the bus.

The internal state machine has two inputs:

- DI
- The current state of A-B (determined by a dedicated differential comparator)

The state machine also has two outputs:

- DRIVER\_ENABLE—Internal signal that enables and disables the driver
- RECEIVER\_ENABLE—Internal signal that is the inverse of the DRIVER\_ENABLE signal, but it can be overridden by an external pin

When DI is low, the device always drives the bus low.

When DI is high, the device drives the bus for a short time, then disables the driver and allows the external pullup/pulldown resistors to hold the bus in the high state. During each low-to-high transition of DI, the driver stays enabled until  $(A-B) > V_{DT}$ , and then disables the driver, letting the pullup/pulldown resistors hold the A and B lines in the correct state.

## Pullup and Pulldown Resistors

The pullup and pulldown resistors on the A and B lines are required for proper operation of the device although their exact value is not critical. They function to hold the bus in the high state following a low-to-high transition. Sizing of these resistors is determined in the same way as when using any other RS-485 driver and depends on how the line is terminated and how many nodes are on the bus. The most important factor when sizing these resistors is to guarantee that the idle voltage on the bus (A-B) is greater than 200mV in order to remain compatible with standard RS-485 receiver thresholds.

## Idle State

When not transmitting data, the MAX13487/ MAX13488 require the DI input be driven high to remain in the idle state. A conventional RS-485 transceiver has DE and  $\overline{RE}$  inputs that are used to enable and disable the driver and receiver. However, the MAX13487/MAX13488 does not have a DE input, and instead uses an internal state machine to enable and disable the drivers. DI must be driven high in order to go to the idle state.

## Hot-Swap Capability

### Hot-Swap Inputs

When circuit boards are inserted into a hot or powered back plane, differential disturbances to the data bus can lead to data errors. Upon initial circuit-board insertion, the data communication processor undergoes its own power-up sequence. During this period, the processor's logic-output drivers are high impedance and are unable to drive the DI and  $\overline{RE}$  inputs of these devices to a defined logic level. Leakage currents up to  $\pm 10\mu\text{A}$  from the high-impedance state of the processor's logic drivers could cause standard CMOS enable inputs of a transceiver to drift to an incorrect logic level. Additionally, parasitic circuit-board capacitance could cause coupling of  $V_{CC}$  or GND to the enable inputs. Without the hot-swap capability, these factors could improperly enable the transceiver's driver.

To overcome both these problems, two different pullup switches (strong and weak) are turned on during the power-up. When  $V_{CC}$  rises, an internal power-up signal enables a strong pullup circuit. It holds DI and RE high with 1mA for 15 $\mu\text{s}$ . Once the timeout is expired, this strong pullup is switched off. A weak pullup (100 $\mu\text{A}$ ) remains active to overcome leakage on the pin. This second weak pullup disappears as soon as the micro-controller forces a low state on these pins.

Therefore, in normal operation (after the first activation), these pins can be considered as high-impedance pins (CMOS inputs) without any pullup circuitry.

The AutoDirection state machine is initialized, forcing the driver disabled. The receiver is enabled in AutoDirection mode.

### Hot-Swap Input Circuitry

The enable inputs feature hot-swap capability. At the input there are two PMOS devices, M1 and M2 (Figure 9). When  $V_{CC}$  ramps from zero, an internal  $15\mu s$  timer turns on M2 and sets the SR latch, which also turns on M1. Transistors M2, a  $1.5mA$  current source, and M1, a  $500\mu A$  current source, pull  $\overline{RE}$  to  $V_{CC}$  through a  $5k\Omega$  resistor. M2 is designed to pull  $\overline{RE}$  to the disabled state against an external parasitic capacitance up to  $100pF$  that can drive  $\overline{RE}$  high. After  $15\mu s$ , the timer deactivates M2 while M1 remains on, holding  $\overline{RE}$  high against three-state leakages that can drive  $\overline{RE}$  low. M1 remains on until an external source overcomes the required input current. At this time, the SR latch resets and M1 turns off. When M1 turns off,  $\overline{RE}$  reverts to a standard, high-impedance CMOS input. Whenever  $V_{CC}$  drops below  $1V$ , the hot-swap input is reset.  $\overline{RE}$  has similar hot-swap circuitry.

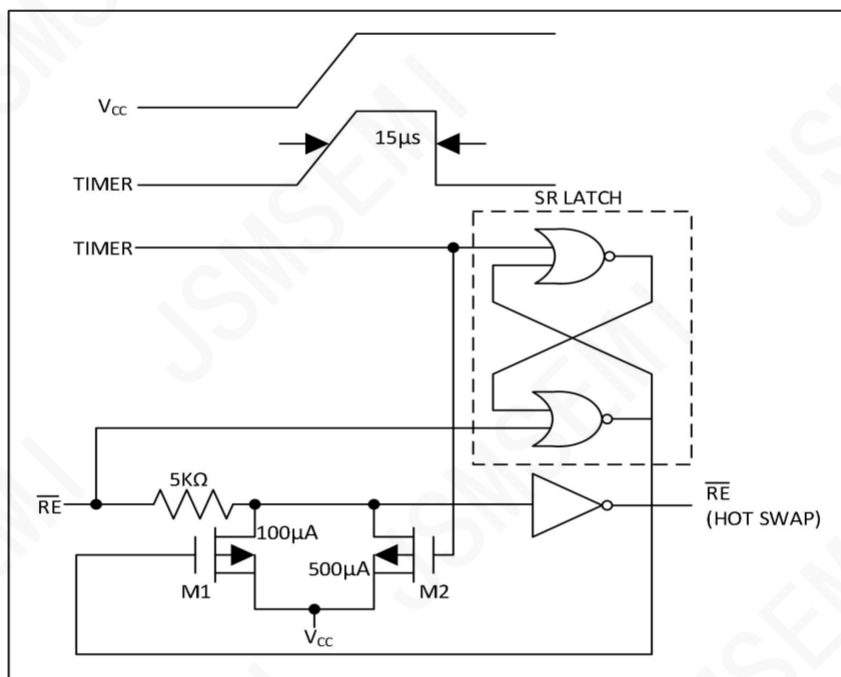


Figure 9. Simplified Structure of the Receiver Enable Pin ( $\overline{RE}$ )

## Application Information

### 256 Transceivers on the Bus

The standard RS-485 receiver input impedance is 12kΩ (1-unit load), and the standard driver can drive up to 32-unit loads. The MAX13487/MAX13488 have a 1/8-unit load receiver input impedance (96kΩ), allowing up to 256 transceivers to be connected in parallel on one communication line. Any combination of these devices, as well as other RS-485 transceivers with a total of 32-unit loads or fewer, can be connected to the line.

### Reduced EMI and Reflections

The MAX13487 features reduced slew-rate drivers that minimize EMI and reduce reflections caused by improperly terminated cables, allowing error-free data transmission up to 500kbps.

### Low-Power Shutdown Mode

Low-power shutdown mode is initiated by bringing  $\overline{\text{SHDN}}$  low. In shutdown, the devices draw a maximum of 10μA of supply current.

The devices are guaranteed not to enter shutdown if  $\overline{\text{SHDN}}$  is low for less than 50ns. If the inputs are in this state for at least 700ns, the devices are guaranteed to enter shutdown.

Enable times  $t_{ZH}$  and  $t_{ZL}$  (see the Switching Characteristics section) assume the devices were not in a low-power shutdown state. Enable times  $t_{ZH(\text{SHDN})}$  and  $t_{ZL(\text{SHDN})}$  assume the devices were in shutdown state. It takes drivers and receivers longer to become enabled from low-power shutdown mode ( $t_{ZH(\text{SHDN})}$ ,  $t_{ZL(\text{SHDN})}$ ) than from driver/receiver-disable mode ( $t_{ZH}$ ,  $t_{ZL}$ ).

### Line Length

The RS-485/RS-422 standard covers line lengths up to 4000ft.

### Typical Applications

The MAX13487/MAX13488 transceivers are designed for half-duplex, bidirectional data communications on multipoint bus transmission lines. Figure 10 shows a typical network application. To minimize reflections, terminate the line at both ends in its characteristic impedance, and keep stub lengths off the main line as short as possible. The slew-rate-limited MAX13487 is more tolerant of imperfect termination.

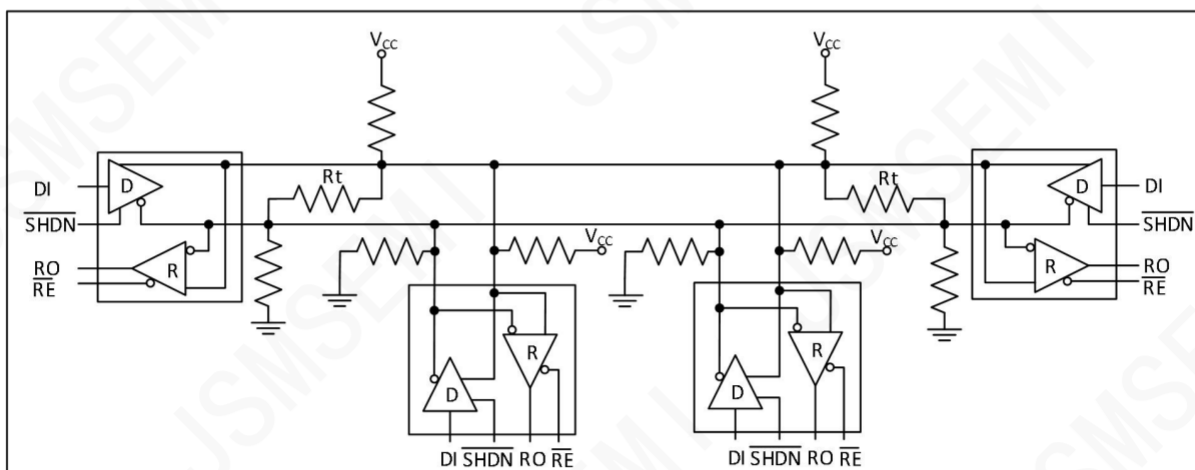
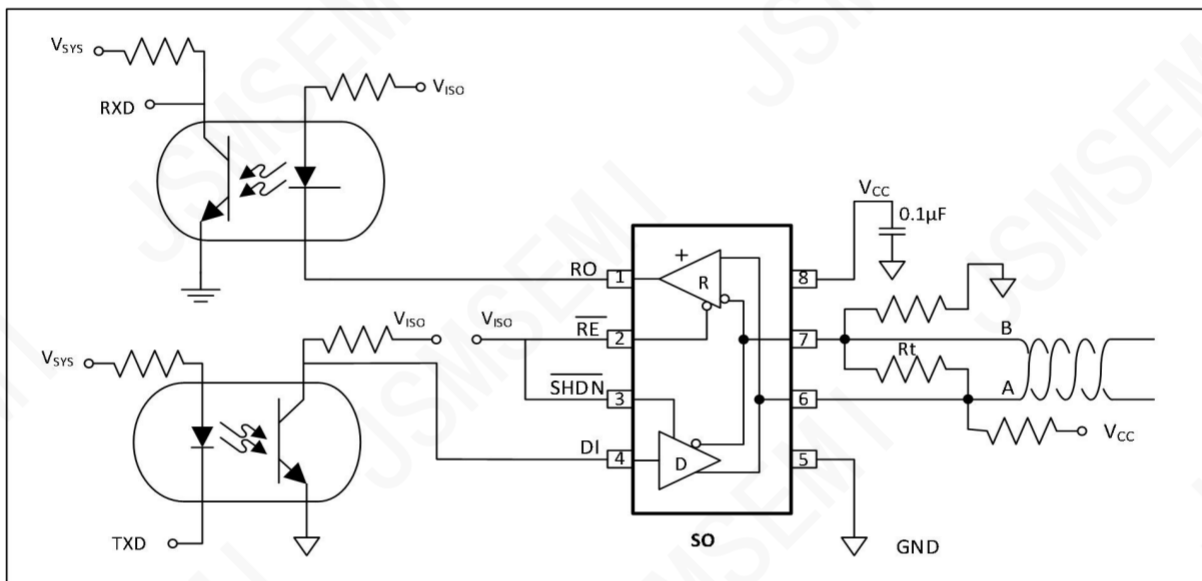


Figure 10. Typical Half-Duplex RS-485 Network

### Isolated RS-485 Interface

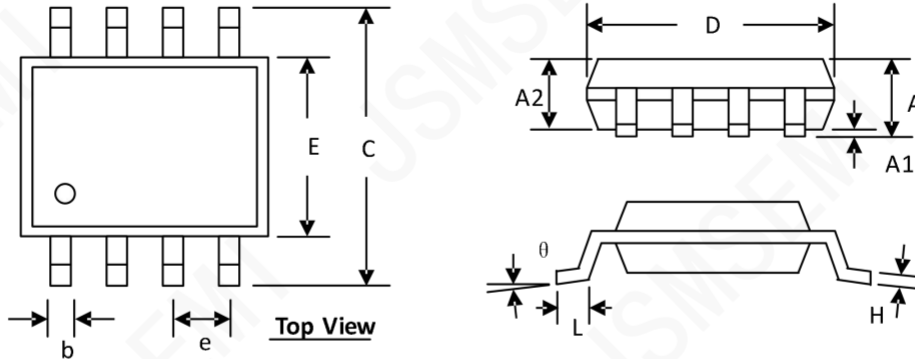
An isolated RS-485 interface electrically isolates different nodes on the bus to protect the bus from problems due to high common-mode voltages that exceed the RS-485 common-mode voltage range, conductive noise, and ground loops. The Typical Application Circuit shows an isolated RS-485 interface using the MAX13487/MAX13488. The transceiver is powered separately from the controlling circuitry. The AutoDirection feature of the MAX13487/MAX13488 (see the AutoDirection Circuitry section), replaces an external relay allowing faster switching speeds, no contact bounce, better reliability, and better electrical isolation. The MAX13487/MAX13488 only require two optocouplers to electrically isolate the transceiver.

### Pin Configuration/Typical Application Circuit





**PACKAGE DIMENSION SOP-8L**



SYMBOLS	DIMENSION (MM)		DIMENSION (INCH)	
	MIN	MAX	MIN	MAX
A	1.300	1.752	0.051	0.069
A1	0.000	0.203	0.000	0.008
A2	1.350	1.550	0.053	0.061
b	0.330	0.510	0.013	0.020
C	5.790	6.200	0.228	0.244
D	4.700	5.110	0.185	0.201
E	3.800	4.000	0.150	0.157
e	1.270 BSC		0.050 BSC	
H	0.170	0.254	0.007	0.010
L	0.400	1.270	0.016	0.050
$\theta$	0°	8°	0°	8°

**Order Information**

Order number	Package	Operation Temperature Range	MSL Grade	Ship, Quantity	Green
MAX13487	SOP8-L	-40 to 85°C	3	T&R, 2500	Rohs
MAX13488	SOP8-L	-40 to 85°C	3	T&R, 2500	Rohs