

RoHS

REV.	ECN NO.	DESCRIPTION	DESIGN	APPROVAL	DATE
A1	NEW	更换图框			2023.09.03

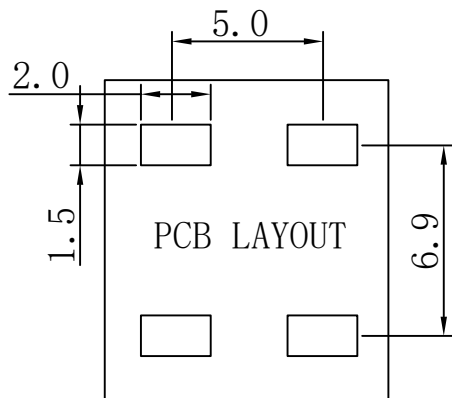
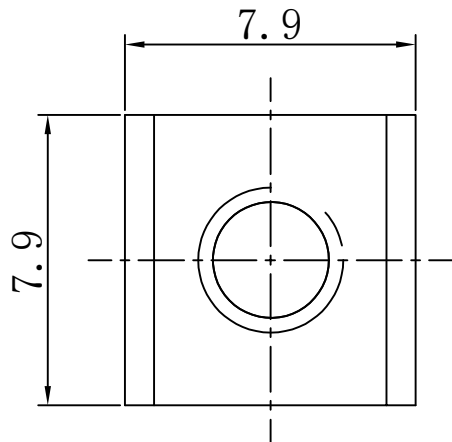

技术要求:

- 1.打铜底 $0.5-1\mu\text{m}$,镍 $2-2.5\mu\text{m}$, 镀雾锡 $3-5\mu\text{m}$ 。
- 2.铆好后不得有松动现象。
- 3.插脚尖部符合可焊性要求。
- 4.螺纹需符合通止规/止针要求。
- 5.螺纹扭矩: 1.0Nm 。
- 6.额定电流: 50A 。

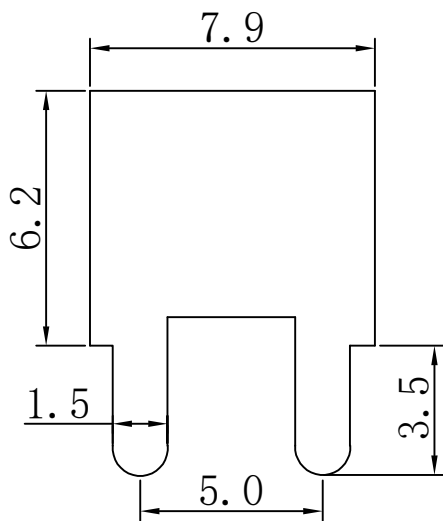
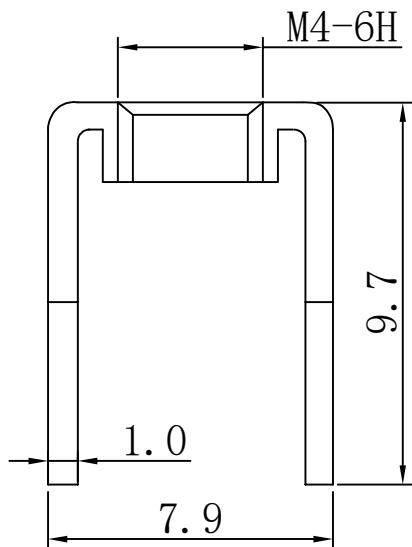

$>30\pm 0.4$	$X^\circ \pm$
$6-30\pm 0.3$	$.X^\circ \pm$
$0-6\pm 0.2$	$.XX^\circ \pm$
ANGLES $\pm 1^\circ$	$.XXX^\circ \pm$
UNITS:	mm

PART NO: T44079079-0970		XFCN 兴飞连接器		
TITLE: PCB SOLDERING TERMINAL		0769-82001899		
		www.xfconn.com		
		DWG NO: /		
APPD	Chen ZhiQiang	VIEW		
CHKD	Liu Wei	SCALE	SHEET	REV
DRAW	Chen HongJiang	NONE	1/1	A1
DATE	2024.09.04			

THESE DRAWINGS AND SPECIFICATIONS ARE THE PROPERTY OF XFCN AND SHALL NOT BE REPRODUCED, COPIED OR CUED IN ANY MANNER WITHOUT THE PRIOR WRITTEN CONSENT OF XFCN

序号	名称	零件编号	材质	数量
1	插脚		H62 (Y2)	1