



钰地半导体
Tudi Semiconductor

Product Specification

TUDI-MAX3486E

3.3V-Powered, $\pm 15\text{kV}$ ESD-Protected, 2.5Mbps and Slew-Rate-Limited True RS-485/RS-422 Transceivers

网址 www.sztdbdt.com 🔍

用芯智造 · 卓越品质

**semiconductor device
manufacturer**

- Design
- research and development
- production
- and sales



Features

- ESD protection for RS-485 I/O pins
 $\pm 15\text{kV}$ —Human Body Model
 $\pm 8\text{kV}$ —IEC 000-4-2, Contact discharge
 $\pm 15\text{kV}$ —IEC 1000-4-2, Air gap discharge
- 3.3V power supply
- Compatible with 5V logic
- 2.5Mbps data rate
- Low current shutdown mode
- -7V to 2V common mode input voltage range
- Current limiting and thermal shutdown for driver over-load protection

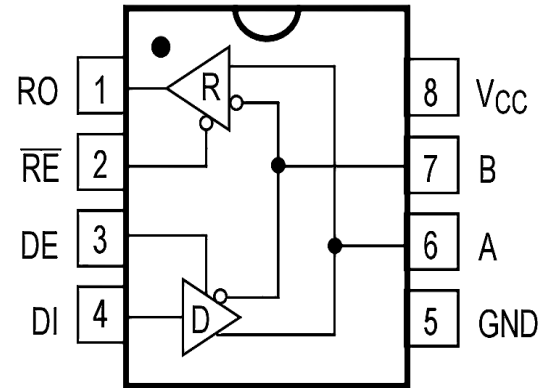

Figure 1. Pin Diagram

Description

The MAX3486E is a low-power, 3.3V transceiver for RS-485 and RS-42 communication with $\pm 15\text{kV}$ ESD protection. Each device contains a driver and a receiver. The MAX3486E has a partial slew rate limiting that allows speeds up to 2.5Mbps. All devices feature enhanced electrostatic discharge (ESD) protection. All drivers and receiver inputs are protected by IEC 100-4-2 air gap discharge ($\pm 15\text{kV}$), IEC 1000--2 contact discharge ($\pm 8\text{kV}$), and human body ($\pm 15\text{kV}$). The driver features short-circuit current limiting and is protected by a thermal shutdown circuit that places the driver output into a high-imped state. The receiver input features a fail-safe function that guarantees a logic high output if both inputs are open. The MAX3486E is designed for half-dup communication.

Applications

- Telecommunications
- Industrial-Control Local Area Networks
- Transceivers for EMI-Sensitive Applications
- Integrated Services Digital Networks
- Packet Switching



Pin description

Pin Number	Pin Name	FUNCTION
1	RO	Receiver Output. When enabled, if $A-B \geq -10\text{mV}$, then $RO = \text{high}$. If $A-B \leq -200\text{mV}$, then $RO = \text{low}$
2	/RE	Receiver Output Enable. A low level enables the RO; a high level places it in a high impedance state.
3	DE	Driver Output Enable. A high level enables the driver differential outputs, Pin A and Pin B; a low level places the driver in a high impedance state.
4	DI	Driver Input. When the driver is enabled, a logic low on DI forces Pin A low and Pin B high; a logic high on DI forces Pin A high and Pin B low.
5	GND	Ground Connection (0V).
6	A	No inverting Receiver Input A/Driver Output A
7	B	Inverting Receiver Input B/Driver Output B.
8	VCC	Power Supply

Parameter limit

PARAMETER	Symbol	Value	Unit
CTR Port	/RE, DE, DI	$-0.3 \sim V_{CC} + 0.3$	V
Driver Output Voltage	A, B	$-7 \sim 13$	V
Receiver Output Voltage	RO	$-0.3 \sim V_{CC} + 0.3$	V
Supply Voltage	VCC	+7	V
Continuous Power Dissipation	MSOP8, SOP8, DIP8	830	mW
Soldering Temperature (reflow)		300	°C
Storage Temperature Range		$-60 \sim 150$	°C
Temperature Range		$-40 \sim 85$	°C

Stresses beyond those listed under “Parameter limit” may cause permanent damage to the device. These are stress ratings only and functional operation of the device at these or any other conditions beyond those indicated in the operational sections of the specifications are not implied. Exposure to absolute maximum rating conditions for extended periods may affect device reliability



Receiver Switching Characteristics

Parameter	symbol	Test condition	Minimum	Typical case	Maximum	Unit
Propagation delay from receiver input to output, from low to high	tRPLH	CL=15pF See Figures 7 and 8		80	150	ns
The propagation delay from receiver input to output is from high to low	tRPHL			80	150	ns
tRPLH-tRPHL	tRPDS			7	10	ns
Enable low time out	tRPZL	CL=15pF See Figures 7 and 8		20	50	ns
Enable to output high time	tRPZH	CL=15pF See Figures 7 and 8		20	50	ns
Time from output low to disable	tpRLZ	CL=15pF See Figures 7 and 8		20	45	ns
Time from out-put high to disable	tpRHZ	CL=15pF See Figures 7 and 8		20	45	ns
Off stateEnable to output high time	tRPSH	CL=15pF See Figures 7 and 8		200	1400	ns
Off stateEnable low time out	tRPSL	CL=15pF See Figures 7 and 8		200	1400	ns
Time to turn off	tsHDN	NOTE	80		300	ns

NOTE: When /RE=1 and DE=0, the device will not enter shutdown mode if the duration is less than 80ns;however, it will definitely enter shutdown mode if the duration exceeds 300ns



supply current						
Parameter	symbol	Test condition	Minimum	Typical case	Maximum	Unit
Supply current	I _{CC1}	/RE=0V,DE=0V		520	800	uA
	I _{CC2}	/RE=VCC,DE=VCC		540	700	uA
Turn-off current	I _{sHDN}	/RE=VCC,DE=0V		0.5	10	uA
Drive Switch Characteristics						
Parameter	symbol	Test condition	Minimum	Typical case	Maximum	Unit
Driver differential output delay	t _{DD}	R _{DIFF} =60 Ω, C _{L1} =C _{L2} =100pF (see Figure 3 and Figure 4)		10	35	ns
Drive differential output transition time	t _{TD}			12	25	ns
Drive propagation delay from low to high	t _{PLH}	R _{DIFE} =27 Ω (see Figure 3 and Figure 4)		8	35	ns
Drive propagation delay from high to low	t _{PHL}			8	35	ns
t _{PLH} -t _{PHL}	t _{PDS}			1	8	ns
Enable to output high	t _{pZH}	R _L =110 Ω (see Figure 5 and 6)		20	90	ns
Enable to output low	t _{pZL}			20	90	ns
Input low to disable	t _{PLZ}	R _L =110 Ω (see Figure 5 and 6)		20	80	ns
Enable high input	t _{PHZ}			20	80	ns
Enable high output under off condition	t _{DSh}	R=110 Ω (see Figure 5 and 6)		500	900	ns
Enable low output under shutdown conditions	t _{DsL}	R _L =110 Ω (see Figure 5 and 6)		500	900	ns



DC electrical characteristics of the driver

Parameter	symbol	Test condition	Minimum	Typical case	Maximum	Unit
Driver differential output (non-loaded)	VoD ₁			3.3		V
Drive differential output	VoD ₂	graph 2,RL=54	1.5		VCC	V
		graph 2,RL=100	2		VCC	
Variation in the amplitude of the output voltage (NOTE1)	VoD	graph 2,RL=54			0.2	V
Output common mode voltage	Voc	graph 2,RL=54			3	V
Amplitude Variation of Common Mode Output Voltage (NOTE1)	Voc	graph 2,RL=54			0.2	V
High-level input	VH	DE,DI,/RE	2.0			V
Low level input	V	DE,DI,/RE			0.8	V
Logic input current	IN1	DE,DI,/RE	-2		2	uA
Output the current during a short circuit, with high short-circuit	I _{osD1}	Short circuit to 0V~12V			250	mA
Output the current during a short circuit, down to low	I _{osD2}	Short circuit to -7V~0V	-250			mA
Overtemperature shutdown threshold temperature				140		
Overtemperature turn-off hysteresis temperature				20		



DC Electrical Characteristics of the Receiver

Parameter	symbol	Test condition	Minimum	Typical case	Maximum	Unit
Input current(A,B)	IN2	DE=0V,VCC=0 or 3.3V VIn=12V			125	uA
		DE=0V,VCC=0 or 3.3V VIn=-7V	-100			uA
Forward input threshold voltage	VIT+	-7V Vcm 12V			+200	mV
Reverse input threshold voltage	VIT-	-7V Vcm 12V	-200			mV
Input hysteresis voltage	Vhys	-7V Vcm 12V	10	30		mV
High level output voltage	VoH	IoUT=-2.5mA,VID =+200 mV	VCC-1.5			V
Low level output voltage	VoL	IoUT=+2.5mA,VD =-200 mV			0.4	V
Three-state input leakage current	IozR	0.4V<Vo<2.4V			±1	uA
Input resistance of receiver	RIn	-7V Vcm 12V	96			k
Receiver short circuit current	IosR	0V Vo VCC	±8		±60	mA



FUNCTION TABLES

TRANSMITTING					RECEIVING				
CTR	/RE	X	X	0	1	0	0	0	1
	DE	1	1	0	0	X	X	X	X
INPUTS	DI	1	0	X	X				
	A-B					$\geq -10\text{mV}$	$\leq -200\text{mV}$	Open/shorted	X
OUTPUTS	A	H	L	Z					
	B	L	H	Z					
	RO					H	L	H	Z

X:Don't care;Z:high impedance.

TEST CIRCUIT

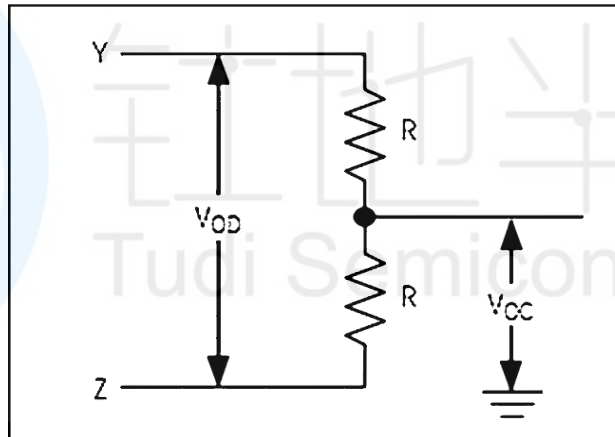

Figure 2 DC test load of the driver

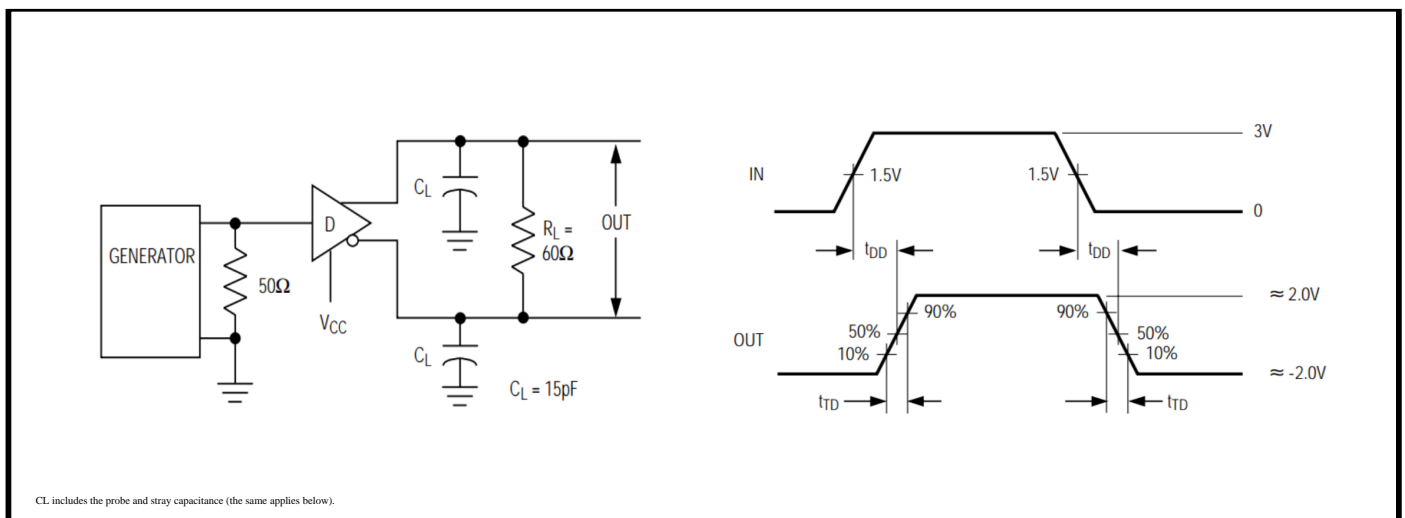

Figure 3 Differential delay and transit time of driver

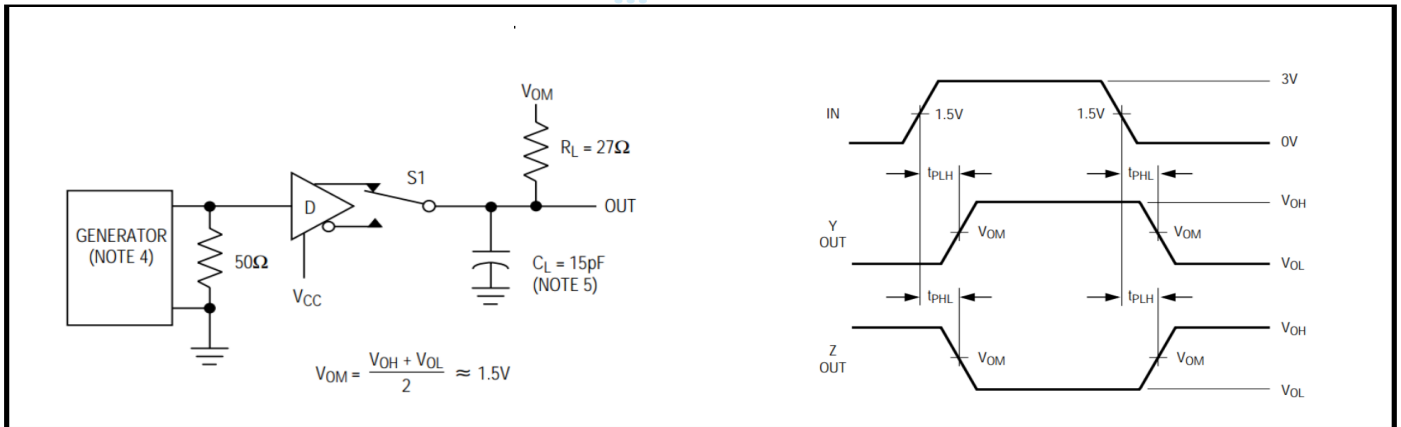

Figure 4 Propagation Delay of Driver

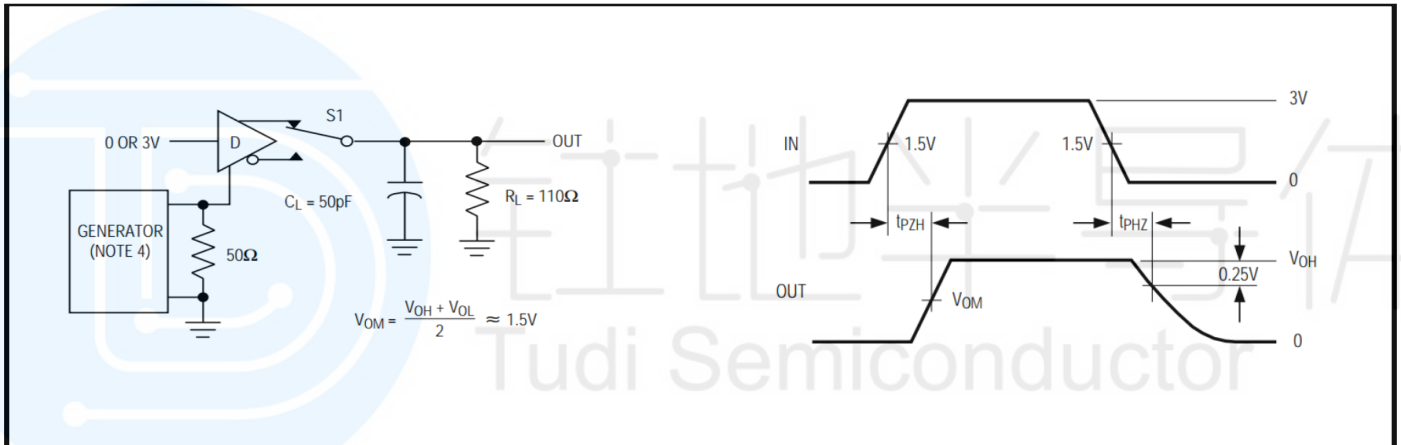

Figure 5 Driver enable and disable time

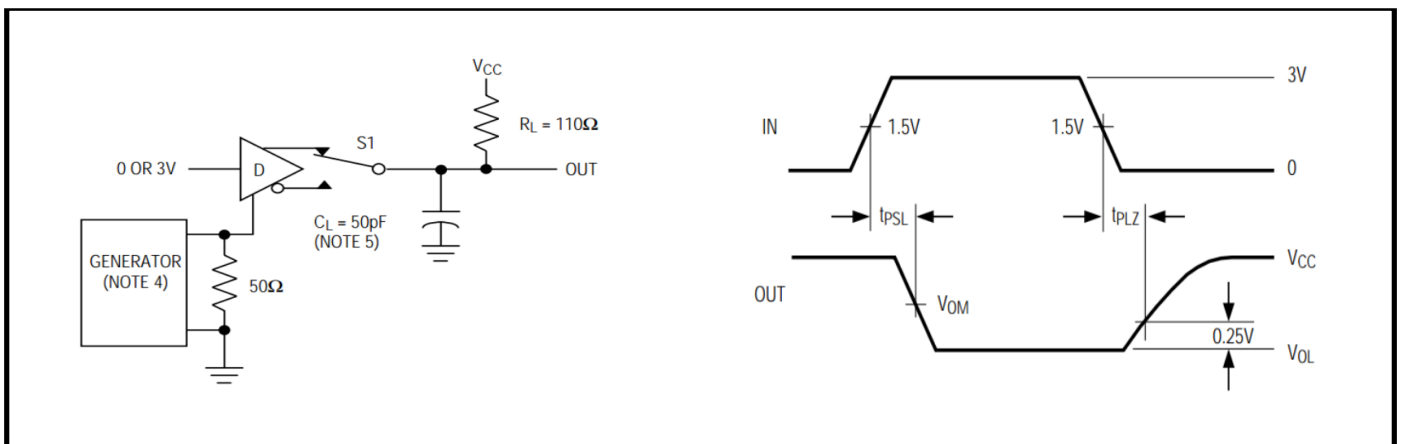
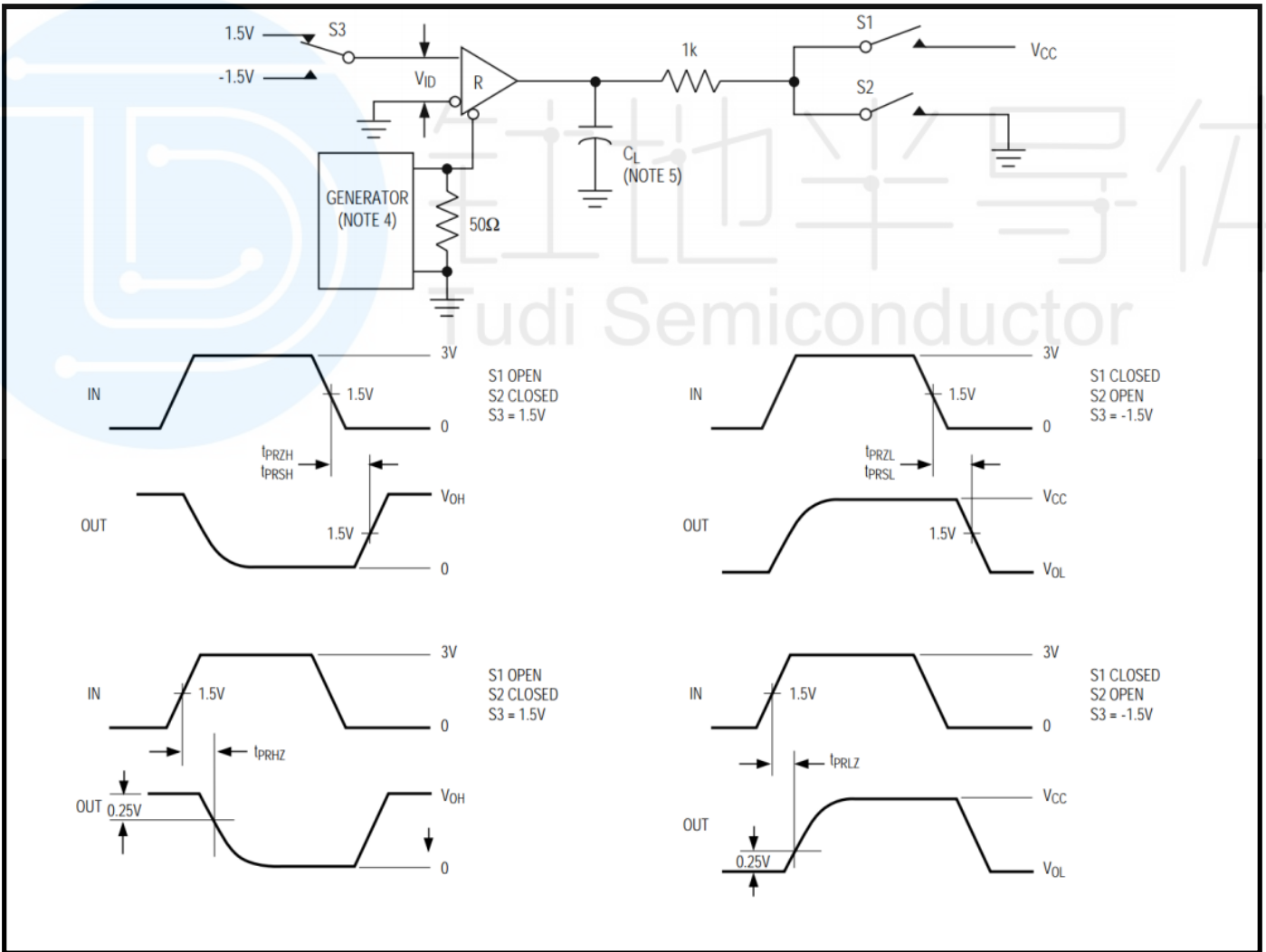
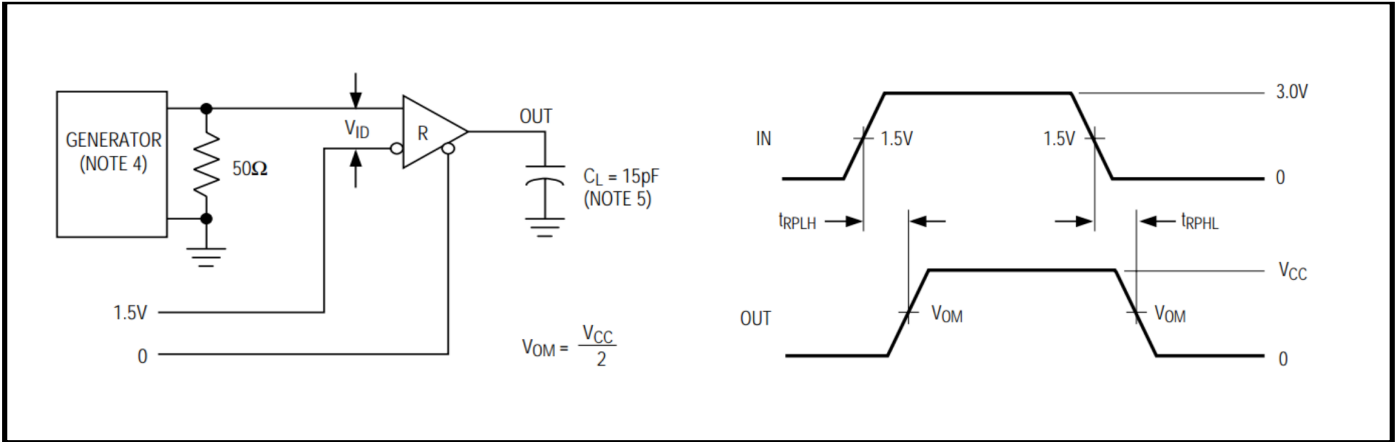

Figure 6 Driver enable and disable time



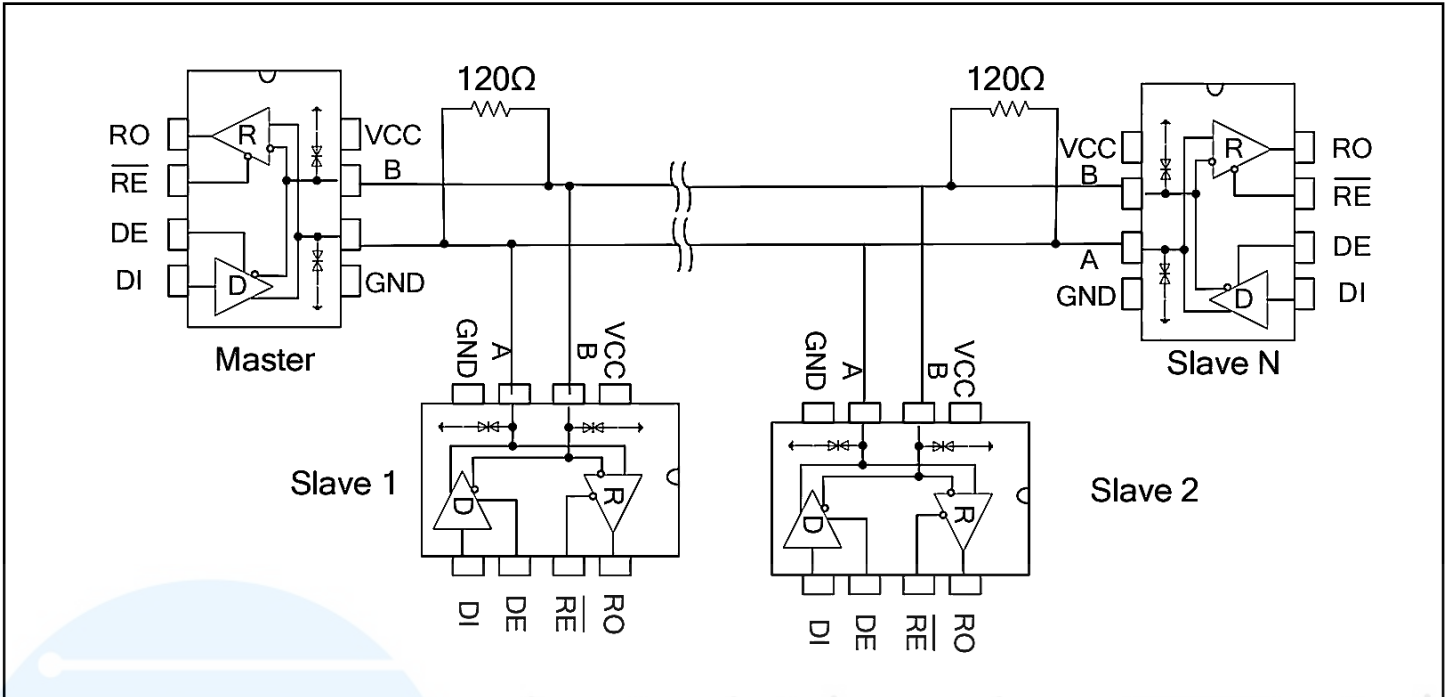

Fig11 Backbone cable type RS485 communications network

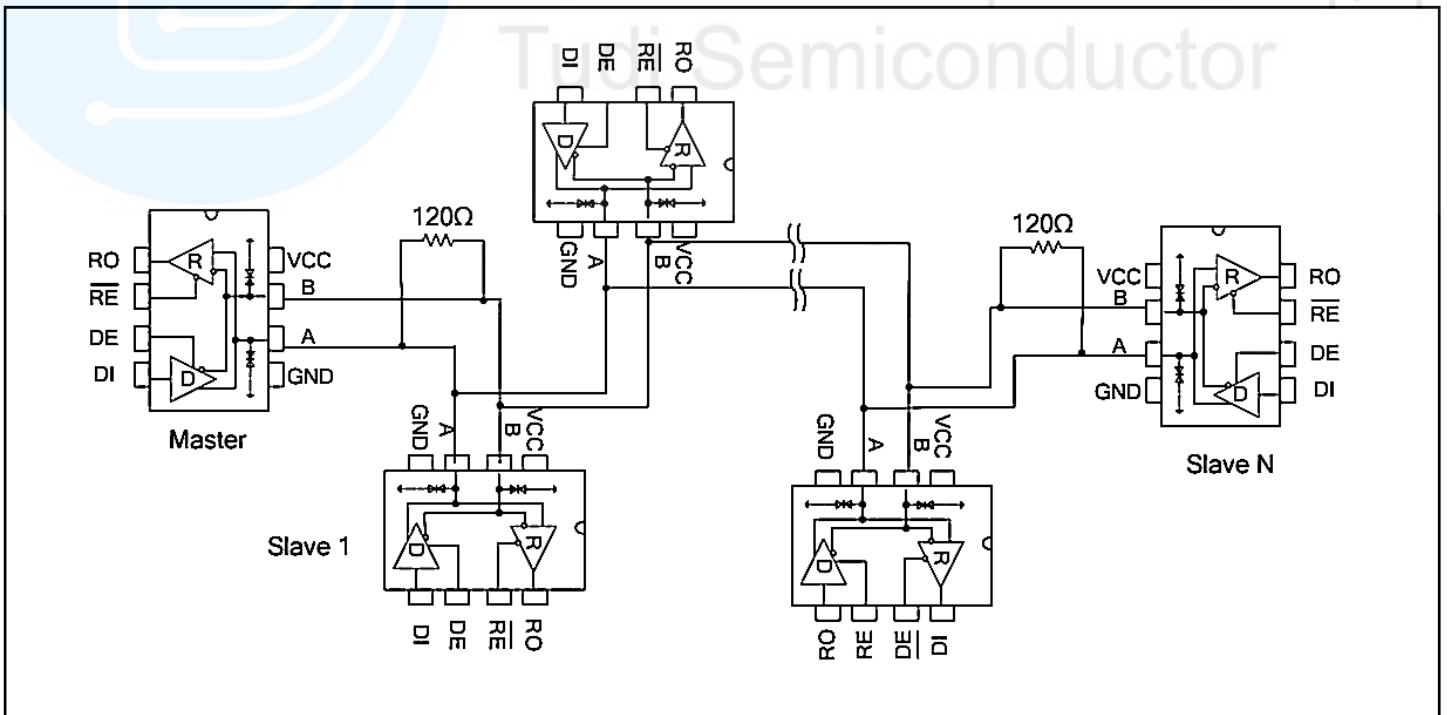

Fig12 Daisy chain topology type RS485 communications network

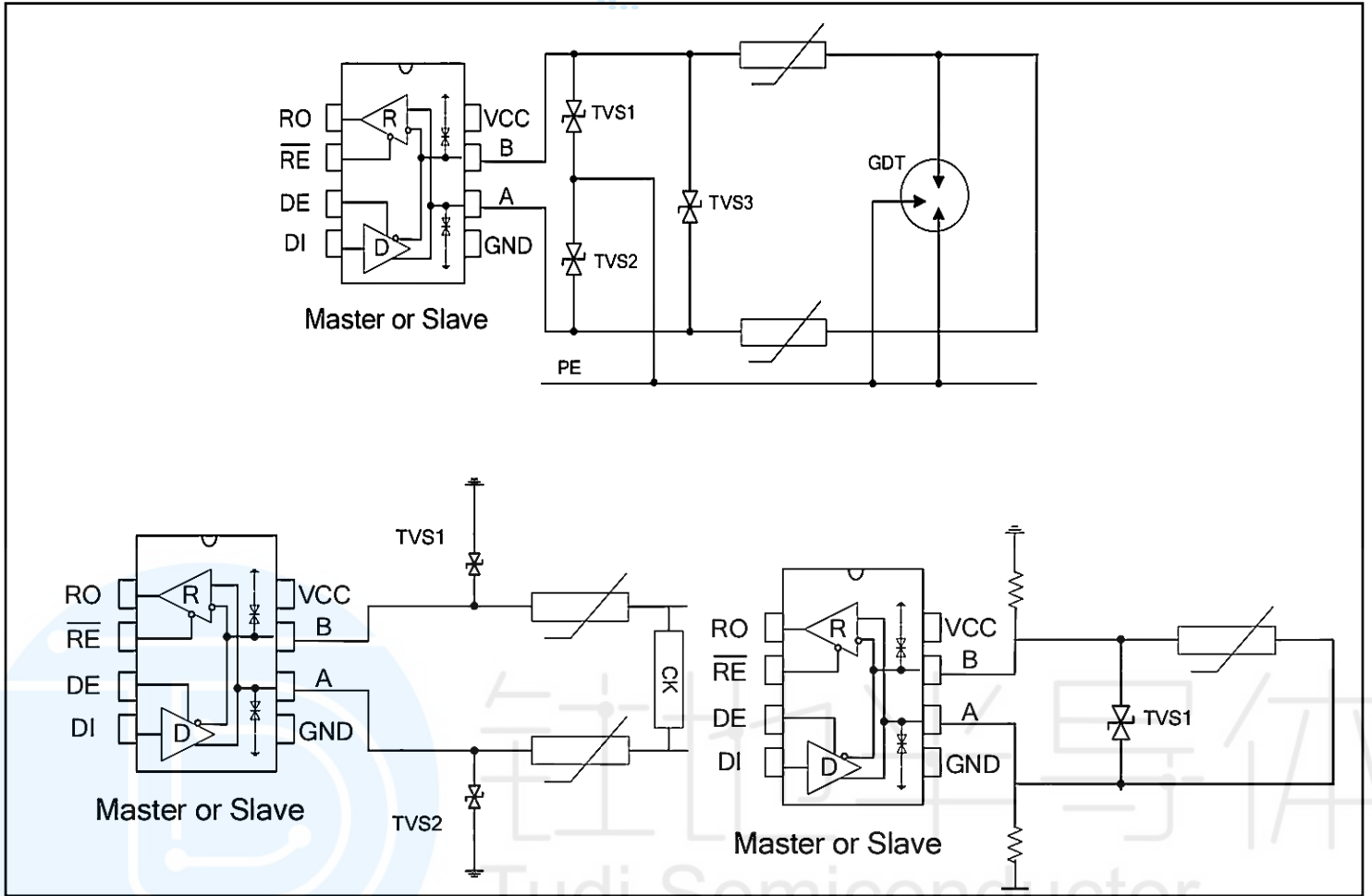

Fig13 RS485 bus ports Protection configuration

Order information

Order Number	Package	Package Quantity	Marking On The park	Temperature
MAX3486ECPA-TUDI	DIP8	Tube,50,A box of 2000	MAX3486ECPA	0°C to 70°C
MAX3486ECSA-TUDI	SOP8	Tape,Reel,2500	MAX3486ECSA	
MAX3486ECPA-TUDI	DIP8	Tube,50,A box of 2000	MAX3486ECPA	- 40°C to 85°C
MAX3486EESA-TUDI	SOP8	Tape,Reel,2500	MAX3486EESA	



Additional description

Description

3486E, including a driver and a receiver, is a half-duplex high-speed transceivers for RS-485 / RS-422 communications. 3486E features fail-safe, overvoltage protection, overcurrent protection, thermal protection, and allows / RE, DE hot-swappable. The 3486E allows an error-free data transmission up to 2.5Mbps.

Typical Application

Backbone cable type: 3486E transceiver is designed for multi-point bi-directional data communication bus transmission lines. Figure 11 shows a typical network application circuit. These devices can also be used as a cable longer than 4,000 feet of line repeater, to reduce the reflection, the transmission line should be in its ends terminated in its characteristic impedance, and stub lengths off the main line should be as short as possible. Hand in hand type: Also known as daisy chain topology, is the prior RS485 bus topology recommended by the TIA organization. The routing method is the master device and a number of slave devices connected in hand-handle configuration, as shown in Figure 12. It should be noted that hand in handle means no branch line. This kind of topology has the advantages of small reflection and high rate of success communication. The bus port protection: In harsh environments, RS485 communication ports are usually done with static protection, lightning surge protection, and other additional protection, even prepared to prevent 380V electricity access by mistake. To avoid the destruction of intelligent instruments and industrial control host, figure 13 demonstrates three general kinds of RS485 bus port protection configuration.

Connecting 32 Transceivers on one Bus

The standard 3486E receiver input impedance is guaranteed $>12k\ \Omega$, the standard driver can drive up to 32 unit loads. These devices can be any combination, or in combination with other RS-485 transceiver combination, as long as the total load does not load more than 32 units, can be connected on the same bus.

Drive Output Protection

Through two mechanisms to avoid failure or a bus contention causes power consumption is too high. First, in the entire common Mode voltage range, overcurrent protection circuit provides a fast short protection. Second, when the die temperature exceeds 150°C , driver output is forced into a high impedance state by the thermal shutdown circuit.

Fail Safe

When the receiver inputs are shorted or open, or when they are connected to a terminated transmission line with all drivers disabled, 3486E guarantees a logic-high receiver output. This is done by the receiver input thresholds are set between -10mV and -200mV . If the differential receiver input voltage $(A-B) \geq -10\text{mV}$, RO is logic high; if the voltage $(A-B) \leq -200\text{mV}$, RO is logic low. When attached to the terminal all transmitters on the bus are disabled, the receiver differential input voltage is pulled to 0V by the termination resistor. With the receiver threshold of the 3486E, this results in a logic-high with a 10mV minimum noise margin. The -10mV to -200mV threshold complies with the $\pm 200\text{mV}$ EIA/TIA-485 standard.



Package SOP8

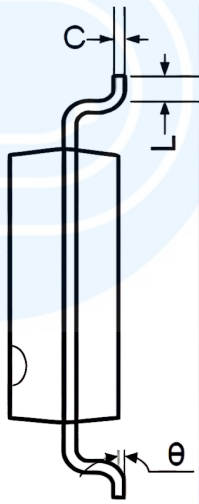
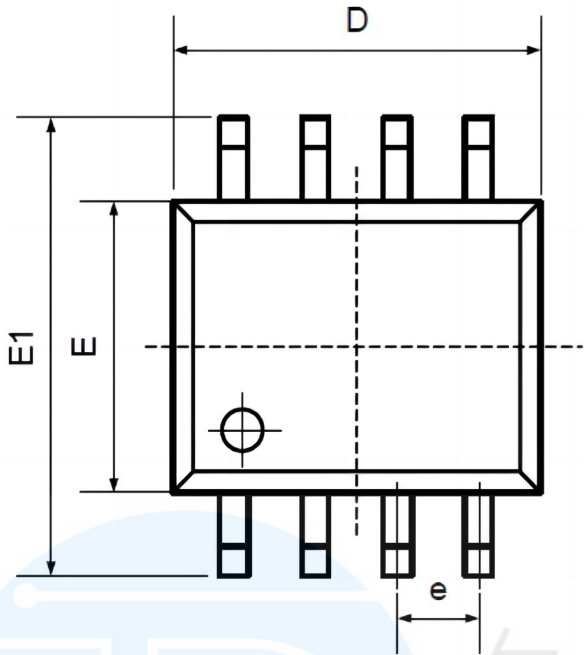

Symbol	Dimensions In Millimeters		Dimensions In Inches	
	Min	Max	Min	Max
A	1.350	1.750	0.053	0.069
A1	0.100	0.250	0.004	0.010
A2	1.350	1.550	0.053	0.061
B	0.330	0.510	0.013	0.020
C	0.190	0.250	0.007	0.010
D	4.780	5.000	0.188	0.197
E	3.800	4.000	0.150	0.157
E1	5.800	6.300	0.228	0.248
e	1.270TYP		0.050TYP	
L	0.400	1.270	0.016	0.050
theta	0°	8°	0°	8°

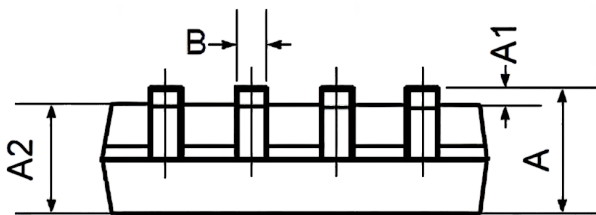



Package DIP8

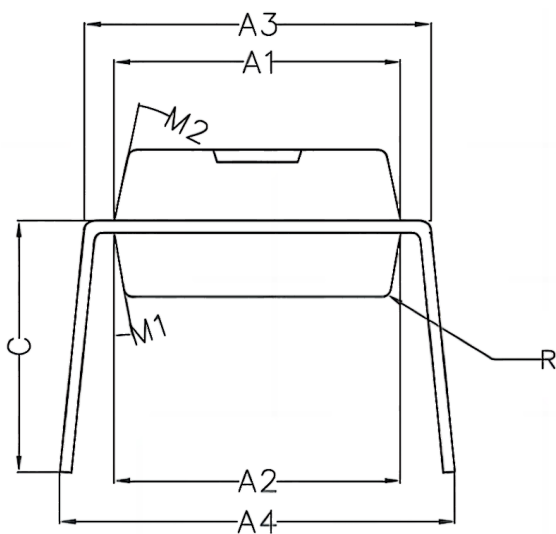
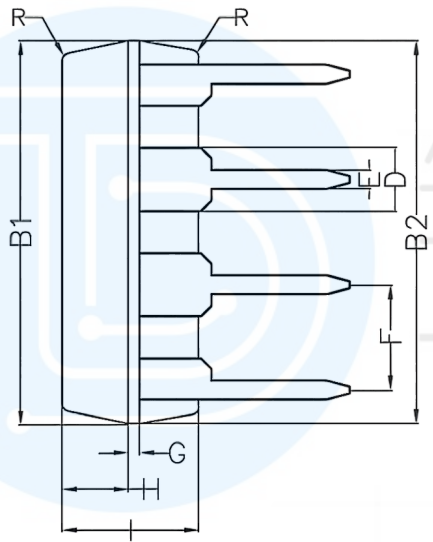
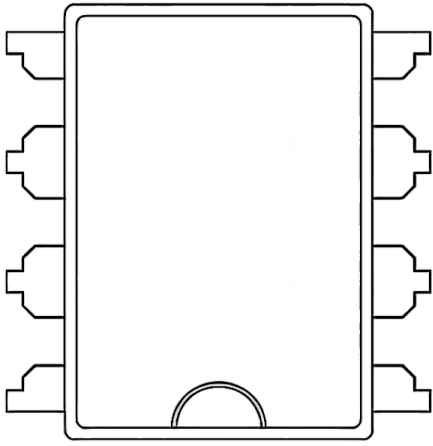

Symbol	Min	Non	Max
A1	6.28	6.33	6.38
A2	6.33	6.38	6.43
A3	7.52	7.62	7.72
A4	7.80	8.40	9.00
B1	9.15	9.20	9.25
B2	9.20	9.25	9.30
C		5.57	
D		1.52	
E	0.43	0.45	0.47
F		2.54	
G		0.25	
H	1.54	1.59	1.64
I	3.22	3.27	3.32
R		0.20	
M1	9°	10°	11°
M2	11°	12°	13°



Important statement:

- TUDI Semiconductor reserves the right to modify the product manual without prior notice! Before placing an order, customers need to confirm whether the obtained information is the latest version and verify the completeness of the relevant information.
- Any semi-guide product is subject to failure or malfunction under specified conditions. It is the buyer's responsibility to comply with safety standards when using TUDI Semiconductor products for system design and whole machine manufacturing. And take the appropriate safety measures to avoid the potential in the risk of loss of personal injury or loss of property situation!
- TUDI Semiconductor products have not been licensed for life support, military, and aerospace applications, and therefore TUDI Semiconductor is not responsible for any consequences arising from the use of this product in these areas.
- If any or all TUDI Semiconductor products (including technical data, services) described or contained in this document are subject to any applicable local export control laws and regulations, they may not be exported without an export license from the relevant authorities in accordance with such laws.
- The specifications of any and all TUDI Semiconductor products described or contained in this document specify the performance, characteristics, and functionality of said products in their standalone state, but do not guarantee the performance, characteristics, and functionality of said products installed in Customer's products or equipment. In order to verify symptoms and conditions that cannot be evaluated in a standalone device, the Customer should ultimately evaluate and test the device installed in the Customer's product device.
- TUDI Semiconductor documentation is only allowed to be copied without any alteration of the content and with the relevant authorization. TUDI Semiconductor assumes no responsibility or liability for altered documents.
- TUDI Semiconductor is committed to becoming the preferred semiconductor brand for customers, and TUDI Semiconductor will strive to provide customers with better performance and better quality products.