

修订	标记	修改摘要	签名	日期
REV NO	MARK	REVISION DESCRIPTION	SIGNATURE	DATE
		NEW DRG		2016-03-12

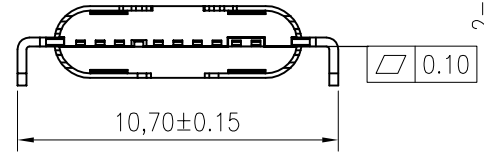
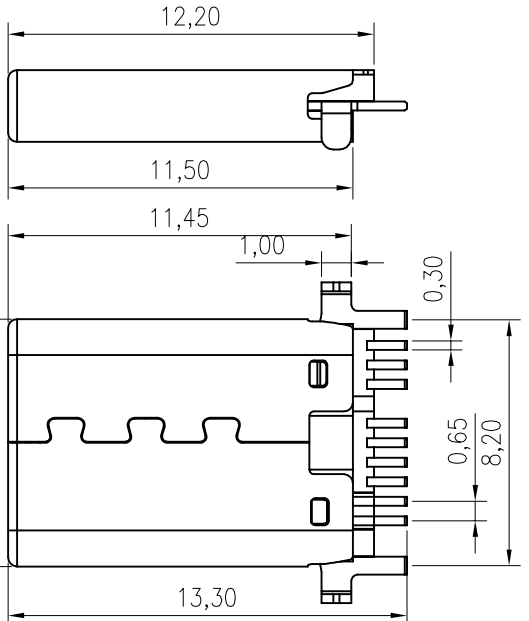
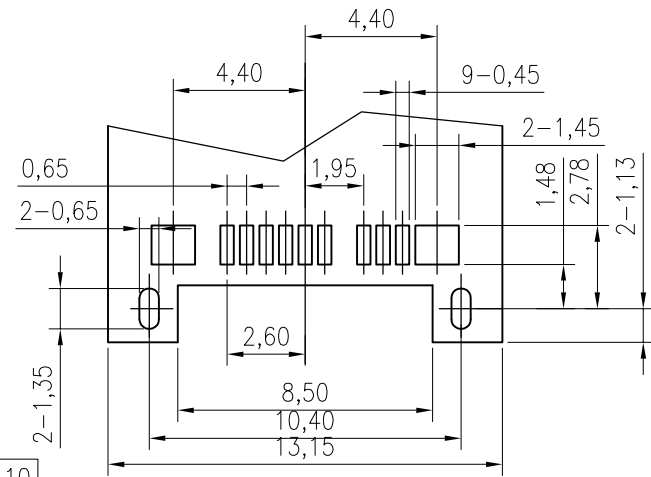
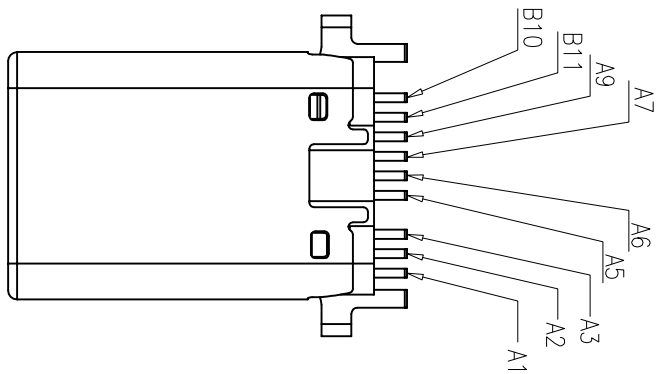
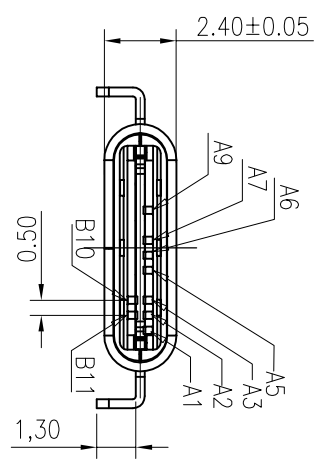

RECOMMENDED P.C.B. LAYOUT
TOLERANCE UNSPECIFIED ±0.05mm

5	EMC SPRING	Stainless Steel;SUS201,T=0.10mm;
4	CONTACT	Copper Alloy;AuNiSn;
3	LATCH	Stainless Steel;SUS301,T=0.3mm;
2	HOUSING	LCP Thermoplastic,UL94V-0;
1	SHELL	Stainless Steel;SUS316,T=0.15mm;
NO.	NAME	DESCRIPTION

A12	A11	A10	A9	A8	A7	A6	A5		A3	A2	A1
			VBUS		D-	D+	CC		TX1-	TX1+	GND
									RX1-	RX1+	
B1	B2	B3	B4	B5	B6	B7	B8	B9	B10	B11	B12

Specification:

- Electrical Characteristics:
 - Contact Current Rating: 3 Amperes Max.
 - Rated Voltage: 30V Max.
 - Dielectric Withstanding Voltage: AC 100V r.m.s.
 - Insulation Resistance: 100 MΩ Minimum.
 - Contact Resistance: 40 mΩ Maximum.
- Environmental:
 - Operating Temperature: -30°C~+85°C.
- Mechanical Characteristics:
 - Insertion Force: 5~20Nf.
 - Withdrawal Force: 8~20Nf.
 - Durability Cycles: 10000 Cycles.

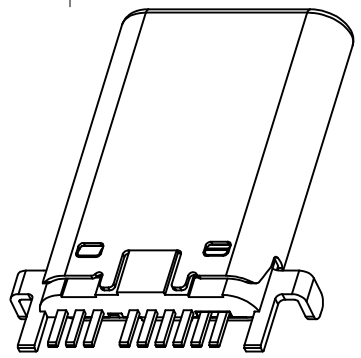

深圳市华德共创科技有限公司
Shenzhen Huade co-create Technology Co.,LTD
电话: 0755-27111216 传真: 0755-29940187

-TOLERANCES- UNLESS OTHERWISE SPECIFIED 公差参数表				TITLE: 产品名称: TYPEC 公头9PIN铆压有脚				
X.X	±0.30	X.X*	±3°	APPD: 核准:	PART NO: 产品编号: TYPEC-ZD-101PWB			
X.XX	±0.20	X.XX*	±2°	CHECK: 校对: 王建业	DATE	SCALE	UNIT	CODE NUMBER
X.XXX	±0.10	X.XXX*	±1°	DRAW: 绘图: 黄艳兰	2016-03-12	1:1	mm	A001

由Autodesk教育版产品制作

由Autodesk教育版产品制作