

1 POGO PIN 2 REAC/ROHS

REV	ECN NO	DESCRIPTION	DESIGN	APPROVAL	DATE
A1	NEW	Replace frame			2018.06.12

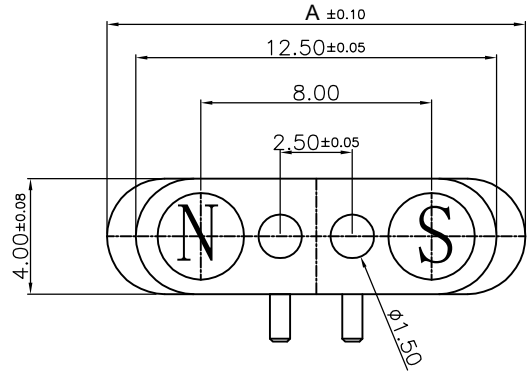

SERIES	PIN NO	A:mm
PR5W4036-F	2PIN	14.50
	3PIN	17.00
	4PIN	19.50
	5PIN	22.00
	6PIN	24.50
	7PIN	27.00
	8PIN	29.50
	9PIN	32.00
	10PIN	34.50
	11PIN	37.00
	12PIN	39.50

- otes:
 Characteristics:
 A. Material (材料)
 1) Housing: High Plastic Black (UL94V-0)
 2) Plunger: brass c3604
 3) Barrel: brass c3604
 4) Spring: Stainless steel wire.
 B. Plating (电镀)
 1) Plunger: Plating Min. 3u' Au over Min. 50u' Ni.
 2) Barrel: Plating Min. 0u' Au over Min. 50u' Ni.
 3) Spring: Plating Min. 0u' Au
 C. Electrical (电气性能)
 1) Operating voltage: 12V Max.
 2) Operating current: 3A Max.
 3) Contact resistance: 30mohm Max. at working height (Quiescence).
 D. Mechanical (机械性能)
 1) Total stroke: 1.10mm.
 2) Working height: 1.0mm.
 3) Spring Force: 45gf ± 10gf at working height
 4) Mechanical life: 10,000 cycle min.
 5) Don't exceed the Max. allowed compression
 E. Environmental (工作环境)
 1) Storage and operating temperature range: -40°C ~ +85°C
 2) Humidity range: 10% RH to 90% RH
 3) Salt spray: 48H
 F. Others (其它)
 1) The dimensions marked * are critical, Should be checked in production
 2) RoHS compliant product.

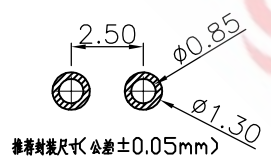
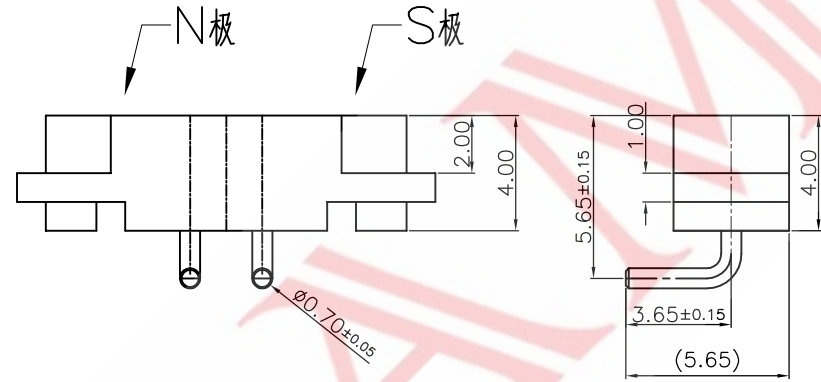

DESIGN	WANGGUIFA	2018.06.12	≥0~2<	±0.15	
CHECKED	ZHENGUILAN	2018.06.12	≥2~5<	±0.25	
APPROVED	LILIANJIANG	2018.06.14	≥0~2<	±0.15	
			≥5	±0.35	

FIRST VIEW

SCALE 1:1 UNIT mm

The copyright belongs to samzo parts [China] Co., Ltd. please use the material after samzo parts agree to authorize. The final right of interpretation belongs to samzo parts. WWW.KKK-JP.COM

TITLE: 2.5PH 90度弯脚 PA4.0
DWG NO: GA02103-P001
PART NO: GA02103230592
MODEL NO: PR5W4036-NP-C-F
NAME: POGO PIN

SAMZO COMPONENTS
 Electronic switch and connector manufacturer