

MSKSEMI 美森科

SEMICONDUCTOR



ESD



TVS



TSS



MOV



GDT



PLED

LM331CXF-MS

Product specification

GENERAL DESCRIPTION

The LM331CXF-MS is a voltage comparator used in integrated circuit. It provides lower offset voltage, higher power supply voltage capability, lower power supply current, lower propagation delay, wider temperature range and higher ESD performance.

The chip supports single power and dual power supply. For dual power supply, the supply voltage ranges from $\pm 1.5V$ to $\pm 16V$, and the V_S is at least $1.5V$ higher than the input common-mode voltage. The output is compatible with TTL and CMOS, and the drain current is not affected by the power supply voltage. The output can be connected to other drain open circuit output to achieve the wired-and" relationship.

The LM331CXF-MS are available in Green SOT23-5. It operates over an ambient temperature range of $-25^{\circ}C$ to $+85^{\circ}C$.

Features

- Wide Supply Range: 3V to 32V
- Low Input Offset: 2mV (Typ)
- Low Quiescent Current:
75 μA at $V_S=5V$
- Low Input Bias Current: 100nA
- Input Common-Mode Voltage Range
- Includes Ground
- Open-Drain Output
- Short Response Time
- SIZE PACKAGES: SOT23-5

Applications

- Hysteresis Comparators
- Floor mopping robot
- One-way UPS
- Server PSU
- Cordless power tool
- Industrial Automation and Control
- Motor driver
- Instruments and apparatus

Pin Description AND MARKING

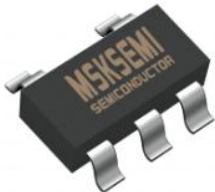
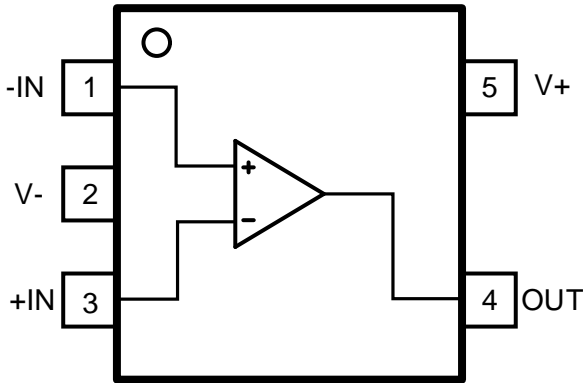
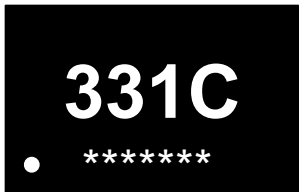
SOT-23-5	Pin Description	Marking
		

Pin Name	Pin Number	I/O	Description
	SOT23-5		
-IN	1	I	Inverting input
V-	2	—	Negative (lowest) power supply
+IN	3	I	Noninverting input
OUT	4	O	Output
V+	5	—	Positive (highest) power supply

Package/Order Information

ORDERING NUMBER	Op Temp(°C)	Package	Packing Option
LM331CXF-MS	-25°C~85°C	SOT23-5	3000PCS

Absolute Maximum Ratings⁽¹⁾

		MIN	MAX	UNIT
Voltage	Supply, $V_s=(V+) - (V-)$		36	V
	Input pin (IN+, IN-) ⁽²⁾	(V-) - 0.3	(V+) + 0.3	V
	Signal output pin ⁽³⁾	(V-) - 0.3	(V+) + 0.3	V
Current	Signal Input pin (IN+, IN-) ⁽²⁾	-10	10	mA
	Signal output pin ⁽³⁾	-55	55	mA
Temperature	Operating Range	-25	85	°C
	Storage	-65	150	°C
	Junction		150	°C

(1) Stresses above these ratings may cause permanent damage. Exposure to absolute maximum conditions for extended periods may degrade device reliability. These are stress ratings only, and functional operation of the device at these or any other conditions beyond those specified is not implied.

(2) Output terminals are diode-clamped to the power-supply rails. Output signals that can swing more than 0.5V beyond the supply rails should be current-limited to ± 55 mA or less.

(3) Short-circuit from output to V_{CC} can cause excessive heating and eventual destruction.

ESD Ratings

			VALUE	UNIT
$V_{(ESD)}$	Electrostatic discharge	Human-body model (HBM), per ANSI/ESDA/JEDEC JS-001, all pins ⁽¹⁾	± 2000	V
		Charged device model (CDM), per JEDEC specification JESD22-C101, all pins ⁽²⁾	± 1000	V

(1) JEDEC document JEP155 states that 500V HBM allows safe manufacturing with a standard ESD control process.

(2) JEDEC document JEP157 states that 250V CDM allows safe manufacturing with a standard ESD control process.

Recommended Operating Conditions

		MIN	MAX	UNIT
Supply voltage, $V_s=(V+) - (V-)$	Single-supply	3	32	V
	Dual-supply	± 1.5	± 16	V

SIMPLIFIED SCHEMATIC

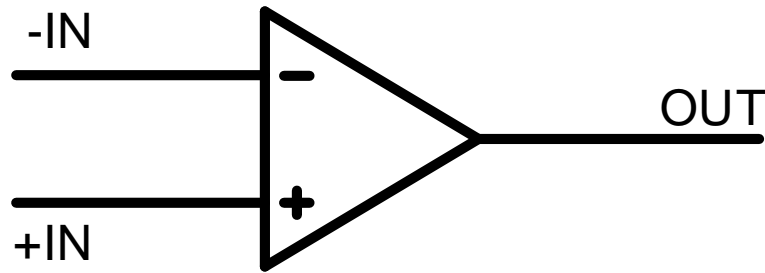

Figure 1. Simplified Schematic

ELECTRICAL CHARACTERISTICS

At $T_A = 25^\circ\text{C}$, $V_S = +5\text{V}$, $V_{IN+} = V_S$, $V_{IN-} = 1.4\text{V}$, $R_{PU} = 10\text{k}\Omega$, unless otherwise noted.

Symbol	PARAMETER	CONDITIONS	MIN	TYP	MAX	UNIT
POWER SUPPLY						
V_S	Operating Voltage Range		3		36	V
I_Q	Quiescent Current /per channel	$V_S = 5\text{V}$		75		μA
		$V_S = 36\text{V}$		110		μA
INPUT CHARACTERISTICS						
V_{OS}	Input offset voltage			2	10	mV
I_B	Input Bias Current	$V_{CM} = V_S/2$		1		nA
I_{OS}	Input Offset Current			1		nA
V_{CM}	Common-Mode Voltage Range		V_{S-}		$V_{S+} - 1.5$	V
A_{VD}	Large-signal Differential-voltage Amplification	$V_S = 15\text{V}$, $V_O = 1.4\text{V to } 11.4\text{V}$, $R_L \geq 15\text{ k}\Omega \text{ to } V_S$	50	200		V/mV
OUTPUT CHARACTERISTICS						
I_{OH}	High-level Output Current	$V_{OH} = 36\text{V}$, $V_{ID} = 1\text{V}$		2	30	nA
I_{OL}	Low-level Output Current	$V_{OL} = 1.5\text{V}$, $V_{ID} = -1\text{V}$		30		mA
V_{OL}	Low-level Output Voltage	$I_{OL} = 4\text{mA}$, $V_{ID} = -1\text{V}$		270		mV

DYNAMIC CHARACTERISTICS						
t_{RT}	Propagation Delay H To L	$V_S=5V$, $R_{PU}=5.1k\Omega$, Overdrive =10mV		485		ns
		$V_S=5V$, $R_{PU}=5.1k\Omega$, Overdrive =100mV		400		
	Propagation Delay L To H	$V_S=5V$, $R_{PU}=5.1k\Omega$, Overdrive =10mV		360		
		$V_S=5V$, $R_{PU}=5.1k\Omega$, Overdrive =100mV		90		

DETAILED DESCRIPTION

Overview

The LM331CXF-MS family of comparators can operate up to 36V on the supply pin. This standard device has proven ubiquity and versatility across a wide range of applications. This is due to its low power and high speed. The open-drain output allows the user to configure the output's logic low voltage (V_{OL}) and can be utilized to enable the comparator to be used in AND functionality.

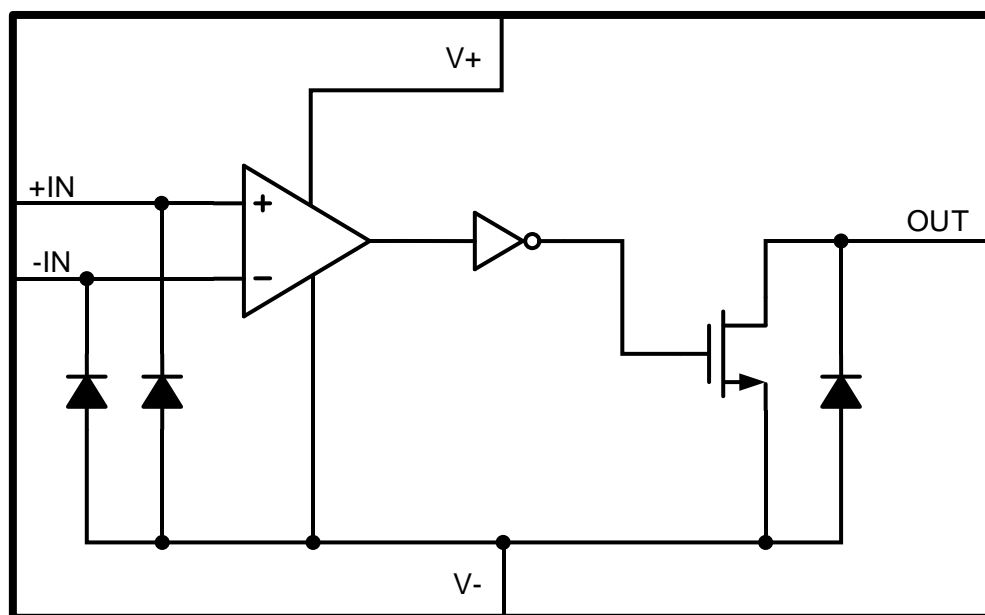
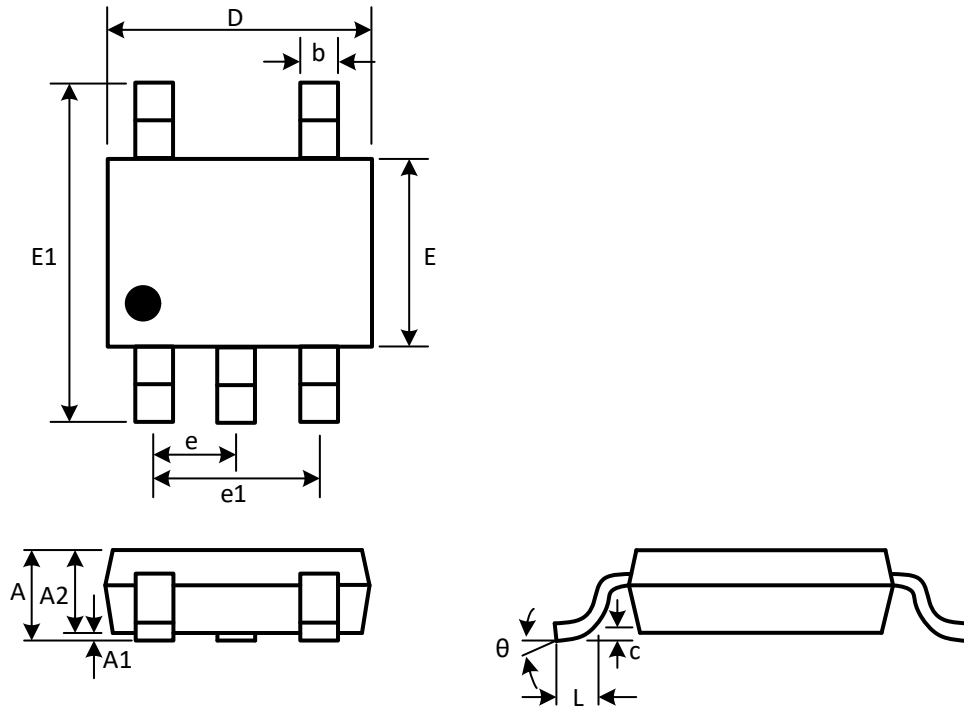

Figure 2. Functional Block Diagram

PACKAGE DESCRIPTION

SOT23-5



(Unit: mm)

Symbol	Min	Max
A	1.050	1.250
A1	0.000	0.100
A2	1.050	1.150
b	0.300	0.500
c	0.100	0.200
D	2.820	3.020
e	0.950(BSC)	
e1	1.800	2.000
E	1.500	1.700
E1	2.650	2.950
L	0.300	0.600
θ	0°	8°

Attention

- Any and all MSKSEMI Semiconductor products described or contained herein do not have specifications that can handle applications that require extremely high levels of reliability, such as life-support systems, aircraft's control systems, or other applications whose failure can be reasonably expected to result in serious physical and/or material damage. Consult with your MSKSEMI Semiconductor representative nearest you before using any MSKSEMI Semiconductor products described or contained herein in such applications.
- MSKSEMI Semiconductor assumes no responsibility for equipment failures that result from using products at values that exceed, even momentarily, rated values (such as maximum ratings, operating condition ranges, or other parameters) listed in products specifications of any and all MSKSEMI Semiconductor products described or contained herein.
- Specifications of any and all MSKSEMI Semiconductor products described or contained herein stipulate the performance, characteristics, and functions of the described products in the independent state, and are not guarantees of the performance, characteristics, and functions of the described products as mounted in the customer's products or equipment. To verify symptoms and states that cannot be evaluated in an independent device, the customer should always evaluate and test devices mounted in the customer's products or equipment.
- MSKSEMI Semiconductor strives to supply high-quality high-reliability products. However, any and all semiconductor products fail with some probability. It is possible that these probabilistic failures could give rise to accidents or events that could endanger human lives, that could give rise to smoke or fire, or that could cause damage to other property. When designing equipment, adopt safety measures so that these kinds of accidents or events cannot occur. Such measures include but are not limited to protective circuits and error prevention circuits for safe design, redundant design, and structural design.
- In the event that any or all MSKSEMI Semiconductor products (including technical data, services) described or contained herein are controlled under any of applicable local export control laws and regulations, such products must not be exported without obtaining the export license from the authorities concerned in accordance with the above law.
- No part of this publication may be reproduced or transmitted in any form or by any means, electronic or mechanical, including photocopying and recording, or any information storage or retrieval system, or otherwise, without the prior written permission of MSKSEMI Semiconductor.
- Information (including circuit diagrams and circuit parameters) herein is for example only ; it is not guaranteed for volume production. MSKSEMI Semiconductor believes information herein is accurate and reliable, but no guarantees are made or implied regarding its use or any infringements of intellectual property rights or other rights of third parties.
- Any and all information described or contained herein are subject to change without notice due to product/technology improvement, etc. When designing equipment, refer to the "Delivery Specification" for the MSKSEMI Semiconductor product that you intend to use.