

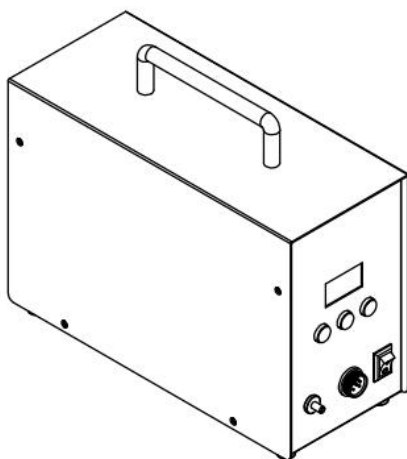

# QUICK 201B Desoldering Tool

## Instruction Manual



**Thank you for purchasing our products. Please keep the instruction manual properly for future reference.**

# Contents

1. Safety Instructions.....	1
2. Overview.....	2
3. Product Characteristics.....	2
4. Product Specifications.....	3
5. Functional Descriptions.....	4
5.1. Dimensions.....	4
5.2. Part Descriptions.....	5
5.3. Key Descriptions.....	7
6. Installment and Connection of        Desoldering Tool.....	7
6.1. Installment of Desoldering Holder and Sponge.....	7
6.2. Connection.....	8
7. Temperature Settings.....	9
7.1. Real-time Temperature Settings.....	9
7.2. General Temperature Settings.....	9
8. Password Settings.....	9
9. Working Modes Settings.....	11
10. Sleeping and Wake Up.....	12
11. Temperature Calibration.....	12
12. Operation.....	13
13. Cleaning and Maintenance of the Nozzle.....	13

13.1.Maintenance of the Nozzle.....	13
13.2.Checking and Cleaning of the Nozzle.....	14
13.2.1.Checking the Nozzle.....	14
13.2.2.Cleaning the Nozzle.....	15
13.3.Replacing the Filter Pipe.....	16
13.4.Installing the Filter Pipe.....	16
14.Replacing the Heater.....	17
14.1.Steps of Removing the Heater.....	17
14.2.Steps of Replacing the Heater.....	18
15. Troubleshooting.....	19
16.Selection of Desoldering Nozzles.....	19

# 1. Safety Instructions



## CAUTION

- During the installation and use of this product, all electrical safety regulations of the country and regions must be strictly observed.
- The power supply must be disconnected when disassembling the product. Do not operate with power on.
- If the product does not work properly, please contact the supplier or our company, and do not disassemble or change the product in any way. We are not responsible for any problems caused by unauthorized maintenance or modification.



## WARNING

- Don't install the product in a place where the surface is easy to shake or be impacted, as it may damage the product.
- Don't place the product in places where it may be exposed to rain or moisture.
- The product should be used away from places where there is magnetic interference.
- Don't use in flammable and explosive environments.
- After using, the nozzle temperature will be quite high, which is easy to burn and may cause dangerous accidents.
- Don't knock workbench with the desoldering tool to remove residual flux, which may seriously damage the desoldering tool.
- After the desoldering tool is used, a layer of melting tin should be plated to prolong its life before placing it into the holder.
- Please unplug the power cord when the product is not used for a long time.

## 2. Overview

This desoldering tool uses high-frequency eddy current heating, which makes the nozzle heat up quickly to melt the solder in the pad of the PCB through-hole devices. The vacuum pump is started by the desoldering tool switch to generate vacuum to suck the liquid solder into the solder storage tube to achieve the purpose of quickly disassembling the through-hole components. At the same time, it can also be used for solder removal on the surface of the pad to improve maintenance efficiency.

## 3. Product Characteristics

- ESD design prevents PCB damage caused by static electricity and electric leakage.
- Built-in powerful vacuum pump, strong suction, no need for external vacuum system, easy to carry.
- The heating system uses closed-loop sensor to control the temperature, precise and accurate.
- The heating element adopts 36V AC low-voltage power supply which is completely isolated by a transformer with the main power supply, safe and reliable.
- LED digital display, temperature adjustment by button, auto sleep function available.
- Digital temperature calibration.
- Suction nozzle and heating pipe are specially designed, even if the solder is in the molten state, it can be sucked into the filter without frequent maintenance, high efficiency.
- With heat proof vacuum hose, prevents contact with heating parts from being damaged.
- The circuit of the vacuum pump for desoldering is equipped with a temperature control switch to prevent the motor from being damaged due to overheating for a long time.

## 4. Product Specifications

Product model	201B
Power consumption	120W
Voltage	AC 110V/220V
Temperature range	200°C~480°C
Pump	Diaphragm type
Vacuum pressure	600mmHg
Nozzle to ground resistance	<2Ω
Nozzle to ground potential	<2mV
Dimensions (L*W*H)	103*252*208mm
Weight	About 4.8Kg

# 5. Functional Descriptions

## 5. 1. Dimensions

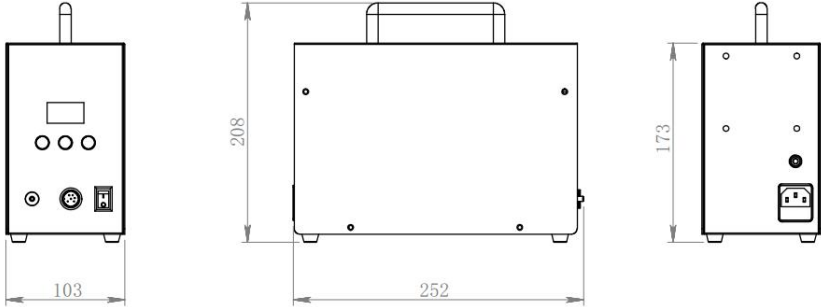

Unit: mm

## 5. 2. Part Descriptions

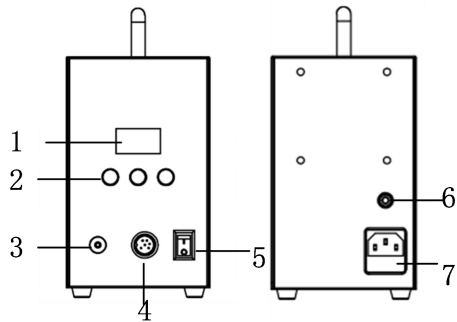

NO.	Part Descriptions
1	LED temperature display, when heating, display the set temperature
2	Temperature control key, set and control the temperature of the nozzle.
3	Fixing pipe connector, connect to the filter hose.
4	Socket, connect the plug of the desoldering tool.
5	Power switch, 1 indicates power on, 2 indicates power off
6	Grounding base, connecting grounding wire
7	Power socket, connecting the power cord.

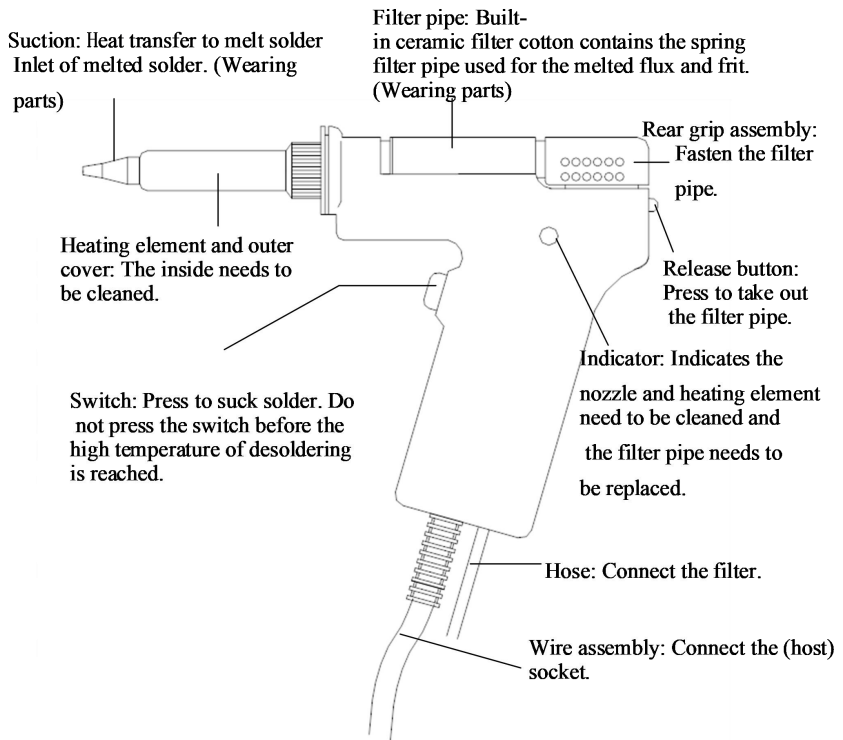

### 5. 3. Key Descriptions

Key	Function Descriptions
▲	Temperature rise, in the working state, press this key, the temperature rises by 1°C; long press, the temperature rises quickly.
*	After adjusting the temperature, press the "*" key to save.
▼	Temperature decrease, in the working state, press "▼", the temperature drops by 1°C; long press, the temperature drops quickly.
*/▲/▼	Press and hold the "*" key, then press the "▲" and "▼" keys simultaneously to enter the temperature calibration interface.

## 6. Installment and Connection of Desoldering Tool

### 6. 1. Installment of Desoldering Holder and Sponge

- 1) Take out the desoldering tool and place it in the holder.
- 2) Place the sponge in the hole of the desoldering holder.

## 6. 2. Connection

Connecting the desoldering tool assembly: make the external filter and the hose of the desoldering tool connected (as shown in the figure below).

- 1) Insert the metal plug of the wire assembly of the desoldering tool into the "IRON" socket of the host, pay attention to positioning and then insert.

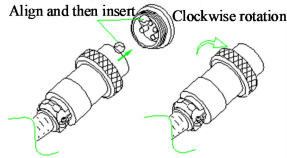

- 2) Insert the power cord into the power socket.
- 3) Connect the external filter with hose of the desoldering tool.
- 4) Turn on the power switch, the displayed temperature lights up, and the desoldering tool starts heating. When the temperature is stable, the heating indicator will flash and the desoldering tool will start heating. (Note: Do not start the desoldering switch if the temperature does not rise to the set temperature)

Note:

\*The external filter has its connection direction, and it shall be connected according to the label, otherwise it will affect the suction of the unit.

\*The desoldering can be carried out after the power switch is turned on for 3 minutes.

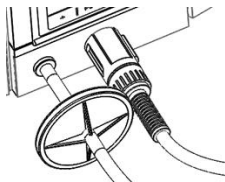

## 7. Temperature Settings

 **Note:** Input the correct password or the original password "000".

### 7. 1. Real-time Temperature Settings

During working mode, set the temperature rapidly.

**Temperature increase:** press "▲" key to set temperature increase by 1°C; long press to increase rapidly.

**Temperature decrease:** press "▼" key to set temperature decrease by 1°C; long press to decrease rapidly.

### 7. 2. General Temperature Settings

"▲" or "▼": number selection key; "\*" : digit selection key.

1) Long press the "\*" key, and the leftmost digit (hundreds) will blink. It indicates to enter the temperature setting mode, and the hundreds digit can be set.

2) Press the "▲" or "▼" key to change the displayed value of hundreds, press the "\*" key to confirm. The operation method of tens and ones are the same as of hundreds.

## 8. Password Settings

### 8.1. Input Correct Password

**Enter the password modification mode**

1) Turn off the power switch. Long press the "▲" and "▼" keys at the same time, then turn on the power switch.

2) Long press the "▲" and "▼" keys until the screen displays:

3) When the screen displays , entering into password settings.

**Input the initial password**

Press "\*" key, the screen displays , and the hundreds digit blinks, indicating entering into password setting mode, the hundreds digit number is adjustable. Press the "▲" or "▼" key to change the displayed value. After selecting the three digits of the password, press the "\*" key for confirmation.

### **If the password input is wrong**

If the screen displays the current input password for two seconds, the desoldering tool enters the working state, indicating the input password is wrong, and the temperature setting and temperature calibration cannot be operated.

### **If the password input is right**



If the screen displays , indicating the input password is correct. After displaying about 4 seconds, the unit enters the working state, the temperature setting can be operated.

## **8.2.New Password Settings**

- 1) When the screen displays , press the "\*" key and displays , indicating the unit enters the new password input state. After entering the new password setting, press the "▲" or "▼" key, and the hundred digit blinks.
- 2) Press the "▲" or "▼" key to select the hundred digit value. After selection, press the "\*" key to confirm and enter the ten-digit number selection. The selection method of ten-digit and one-digit numbers are the same as hundred-digit numbers. After selecting the one digit, press the "\*" key to confirm and enter the second input of the password. The second password setting method is the same as the first password setting method.
- 3) **If the password input twice are different:** the screen displays "Err", indicating that the new password setting is unsuccessful. Until the last two password input values are the same, the password setting will succeed .
- 4) **If the password input twice are same:** the screen displays "OK", in

dicating that the password is set successfully. After shutdown and restart, the new password takes effect.

## 9. Working Modes Settings

1) When the screen displays , press "▲" and "▼" at the same time and it will display , indicating that the desoldering tool has entered in working modes settings state. Press "▲" or "▼" to change the value.

2) After selecting working modes, press "\*" to save.

The meaning of the displayed numbers is shown in the following "Working Modes Sheet". Note: "X" represents the original working mode number. There are four working modes for this desoldering tool, and the default mode is 0.

**Working Modes Sheet**

<b>Working Modes</b>	<b>Adjustable Temperature Range</b>	<b>Applicable Handle Type</b>	<b>Notes</b>
0	200°C~450°C	Desoldering tool/electromagnetic soldering handle	With sleeping function
1	200°C~480°C	Desoldering tool/electromagnetic soldering handle	With sleeping function
0.	200°C~450°C	Desoldering tool/electromagnetic soldering handle	Without sleeping function
1.	200°C~480°C	Desoldering tool/electromagnetic soldering handle	Without sleeping function

## 10. Sleeping and Wake Up

### Sleeping

- 1) Auto-sleeping: If the sleeping mode and working mode have been set, the desoldering tool is not used for 20mins and the screen displays "---" indicating the unit enters the sleeping state.
- 2) When the unit enters the sleeping mode, the temperature of the desoldering tool will drop to 200°C, and the temperature will be maintained until the unit resumes working.

### Wake Up

- 1) Turn off the power switch of the unit, then turn on the power switch.
- 2) Press any key .
- 3) Press the red switch of the desoldering tool. If the unit enters the sleeping state and does not wake up for 40 minutes, the power supply of the desoldering tool will be cut off automatically, and the screen will not display.

## 11. Temperature Calibration

It is recommended to recalibrate the temperature of the unit after replacing the desoldering tool, heating element or nozzle.

- 1) Set a certain temperature according to your request.
- 2) When the temperature is stable, use the thermometer to measure the nozzle temperature and write down the readings.
- 3) Press and hold the "\*" key, then press "▲" or "▼" keys at the same time to enter the temperature calibration mode.
- 4) At this time, the LED shows the hundreds digit of the temperature blinking, press the "▲" or "▼" key to select the value, press "\*" to select the digit, input the reading value of the thermometer, after completed inputting, press the "\*" key to save, the desoldering temperature calibration is completed.

5) Repeat the above steps if there's any temperature difference between the thermometer and desoldering tool.

Note: \* It is recommended to use QUICK 191/192 to measure the nozzle temperature.

\* If the password is locked, the temperature cannot be calibrated, and the correct password must be input before operation.

## 12.Operation

**Melting solder** After the set temperature is stable, use the nozzle of the desoldering tool to melt the solder.

**Solder removal** After confirming that all the soldering solder has been melted, press the red switch (trigger) on the handle to suck the soldering solder.

**Note:** 1) To check if the solder is completely melted, observe the inside of the aperture and the back of PCB, if it is difficult, use the nozzle to shake the pin slightly. If it can be moved, it means that the solder has been melted.

2) Do not shake the pins vigorously. If the pin does not move easily, it indicates the solder has not been completely melted

3) Do not leave any solder residue in the PCB aperture.

## 13.Cleaning and Maintenance of the Nozzle

### 13.1.Maintenance of the Nozzle

After using the desoldering tool, please make maintenance to ensure durability. Solder removal efficiency depends on temperature, quality and quantity of solder and flux. Please follow the following procedures for maintenance according to the usage of the desoldering tool:

- 1) Apply a little solder to the plating part of the nozzle to keep the nozzle shiny.
- 2) If the nozzle is covered with oxide, the thermal conductivity will be weakened. Apply a little new solder on the nozzle to exert the thermal conductivity function.
- 3) Remove the solder inside the nozzle and the heating element, then clean the nozzle with the cleaner, and plate a layer of solder on the nozzle to protect the coating.

**Note:** After the desoldering tool is used, the temperature will be high. During maintenance, please wait it to cool down or wear heat insulation gloves for safe operation.

## 13.2. Checking and Cleaning of the Nozzle

### 13.2.1. Checking the Nozzle

Please observe the indicator, the nozzle hole must be open. Press the desoldering tool switch (trigger) and observe the indicator. If it is red, indicating need to clean the nozzle and heating element, and empty or replace the filter pipe. If it is blue, please continue to use it without cleaning.

△Note: If the nozzle hole is blocked or the solder in the PCB hole is not melted, the indicator operation is inaccurate.

If the suction is obviously weakened, please clean the nozzle and heating element with a cleaning needle.

Normal	Abnormal	Solution
Blue or slight red are visible	More than half of the indicators are red	If more than half of the indicators are red, please replace the filter pipe and clean the inside of the nozzle and heating element.

### 13.2.2.Cleaning the Nozzle

1) Insert the plug into the power socket, and turn on the power switch to heat the nozzle.

2) Clean the nozzle hole with a nozzle needle.

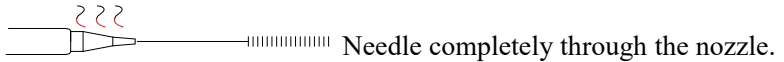

3) If there is slight wear and tear, please re-solder the nozzle with new solder to avoid oxidation.

4) If the nozzle hole is worn or corroded inside and outside, please replace the nozzle.

**Note:** a. Since it is difficult to observe the erosion of the nozzle with naked eyes, if the solder suction efficiency is reduced while the performance of other parts is good, it may be that the nozzle is eroded and should be replaced with a new one.

b. Please select the appropriate size of the needle according to the diameter of the nozzle. If the solder in the nozzle is not completely melted, the needle cannot penetrate the nozzle, please check the solder coating on the nozzle surface.

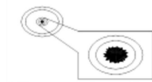
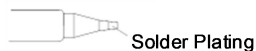

After erosion, the nozzle hole will be enlarged or chipped.

c. A layer of special alloy is plated inside and outside the nozzle aperture. If the alloy layer is eroded due to high temperature, the nozzle will not be able to maintain a proper temperature.

### 13.3.Replacing the Filter Pipe

- 1) Press "OFF" on the power switch.
- 2) When the filter pipe is cooled, press the release button on the back of desoldering tool, and take out the filter pipe.

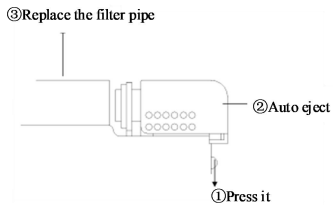

- 3) Check the spring filter pipe and ceramic filter cotton.

Note: The spring filter pipe needs to be replaced when two thirds of the solder is collected and stored.

The ceramic filter cotton needs to be replaced when it is hardened due to the accumulation of solder and flux.

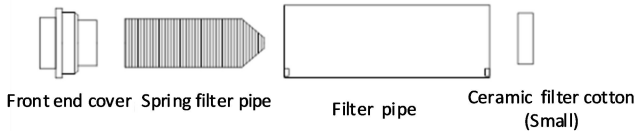

### 13.4.Installing the Filter Pipe

- 1) Install the spring filter pipe on the front end cover.
- 2) Install front end cover on the filter pipe.
- 3) Put the ceramic filter cotton(small) into filter pipe.

Note: If a large filter cotton is loaded into the filter pipe, it may damage the desoldering tool or reduce the suction efficiency.

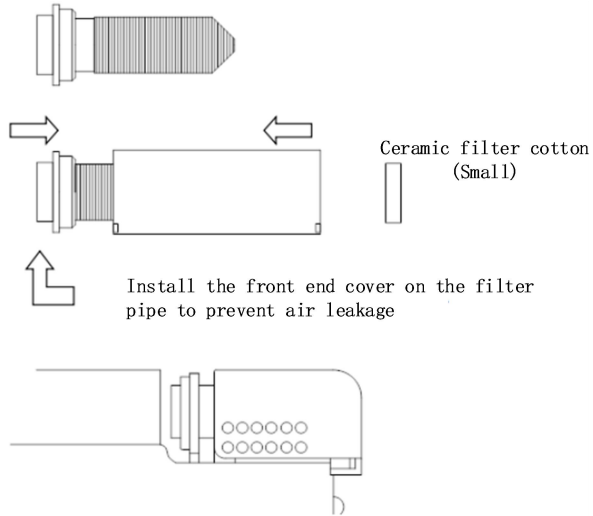

## 14.Replacing the Heater

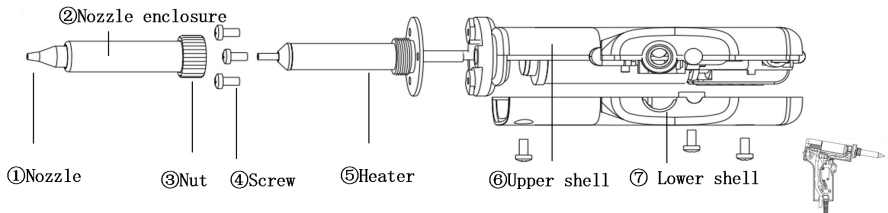

### 14.1.Steps of Removing the Heater

- 1) Unscrew ②Nozzle enclosure and ③Nut, and pull out ①Nozzle.
- 2) Unscrew three④Screws at the tail of the heater.
- 3) Pull off the release button and remove the filter pipe and gasket after the tail seat of the handle pops open.
- 4) Unscrew three screws on ⑥Upper shell.

5) Pull out the four wires of the ⑤Heater at the connector of the handle, and remove the ⑤Heater.

⚠️ Note: All operating steps are performed with the power disconnected and the handle cooled.

## 14.2.Steps of Replacing the Heater

- 1) Fix ⑤Heater on the ⑦Lower shell with three④Screws.
- 2) Insert the four wires of the heater into the handle wire according to the disassembly color.
- 3) Tidy up the wires, toggle the switch to put the wire into the slot, cover ⑥Upper shell, then lock the three screws of the upper shell.
- 4) Place the gasket and the filter pipe in the original position and push the tail seat up.
- 5) Sleeve ①Nozzle on ⑤Heater, then sleeve ②Nozzle enclosure and ③Nut and lock it tightly.
- 6) After the heater is replaced, please do the following measurements:

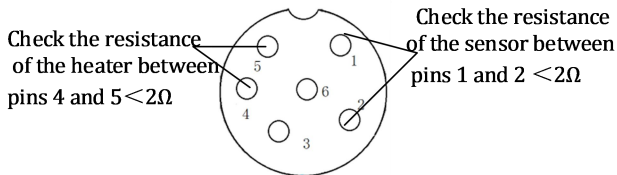

7)After replacing the heater, it is recommended to recalibrate the temperature (refer to the temperature calibration steps).

## 15.Troubleshooting

NO.	Error display	Error description
1	S-E	Sensor error The sensor is not inserted or disconnected
2	H-E	Heater error The heater is open circuit or the power supply circuit is not inserted.

## 16.Selection of Desoldering Nozzles

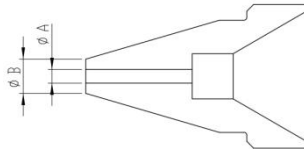

P/N	$\Phi A(\text{mm})$	$\Phi B(\text{mm})$
A1001	0.3	0.7
A1002	1.2	1.8
A1003	1.0	2.0
A1004	0.8	2.3
A1005	1.0	2.5
A1006	1.3	3.0
A1007	2.0	3.0

## Warranty Card

●The warranty period of this product is calculated from the date of Purchase. During the warranty period, if the product breaks down during normal use, show the original warranty card and enjoy free service in the authorized repair company(or our company).

Please keep the purchase certificate and this warranty card and show it before maintenance.

●During the warranty period, the following repairs need to be paid:

- a.Unable to offer valid warranty card or certificate;
- b.The purchase date, sales company and other items are not completely filled or the warranty card is altered;
- c.Damage caused by failure to follow the use methods and precautions in the manual;
- d.Damage caused by disassembly, repair and modification of products without authorization of the manufacturer;
- e.Replacement of vulnerable and consumable parts.

●All items of the warranty card shall be completely filled in by the agent or user to obtain a 12-month warranty period.

●Please keep this warranty card properly It will not be re-offered after.

QUICK INTELLIGENT EQUIPMENT  
CO., LTD.

ADD: NO.11, FengXiang Road, Wujin  
High-Tech Industrial Development  
Zone, Jiangsu, China

TEL: 86-519-86225678

FAX: 86-519-86558599

POSTCODE: 213167

WEBSITE: www.quick-global.com

## Warranty Card

Type: \_\_\_\_\_

Model No.: \_\_\_\_\_

Serial No.: \_\_\_\_\_

Delivery Date: \_\_\_\_\_

## Warranty File Card

Type: \_\_\_\_\_

Model No.: \_\_\_\_\_

Serial No.: \_\_\_\_\_

Delivery Date: \_\_\_\_\_

Address : \_\_\_\_\_

Postcode: \_\_\_\_\_

Telephone: \_\_\_\_\_

Contact Person: \_\_\_\_\_

QUICK INTELLIGENT EQUIPMENT CO., LTD.

ADD: NO.11, FengXiang Road, Wujin  
High-Tech Industrial Development Zone,  
Jiangsu, China

TEL: 86-519-86225678

FAX: 86-519-86558599

POSTCODE: 213167

WEBSITE: [www.quick-global.com](http://www.quick-global.com)

