



DC input side



AC output side



IEC62368-1 BS EN/EN62368-1 (for 112/124 type GFCI only) TPTC004 AS/NZS 62368.1
 Please refer to page3 for more details.

Features

- Built-in UPS function (AC by-pass)
- True sine wave output (THD<3%)
- High surge power up to 2000W
- Temperature controlled cooling fan
- AC output voltage and frequency selectable by DIP S.W
- -25°C ~+70°C wide operating temperature
- Power ON-OFF remote control
- Front panel indicator for operation status
- Protections :
 Input : Reverse polarity / DC low alarm / DC low shutdown / Over voltage
 Output : Short circuit / Overload / Over temp.
- Battery over discharge protection (low voltage disconnect)
- Suitable for lead-acid or li-ion batteries
- Remote controller
 (IRC1, IRC2, IRC3 accessory sold separately, please refer to: <https://www.meanwell.com/webapp/product/search.aspx?prod=IRC1>)
- Support RS-232 communication(Communication cable order No.: RJ11-RS232, sold sperately)
- Carry handle accessory available(Order NO.: Carry handle, sold separately)
- Conformal coating
- 3 years warranty

Applications

- Home and office appliance
- Power tools
- Portable equipment
- Vehicle
- Yacht
- Off-grid solar power system
- Wireless network
- Telecom or datacom system

GTIN CODE

MW Search: <https://www.meanwell.com/serviceGTIN.aspx>

Description

NTU-1200 is a 1200W highly reliable off-grid true sine wave DC-AC power inverter with built-in UPS function(AC by-pass). Its key features include: digital design with MCU control, streamlined control circuitry that quickly responds to environmental changes and improves reliability, high quality fan with low acoustic noise, 2000W peak power, adjustable AC output voltage and frequency, -25~+70°C wide operating temperature range, complete protection features, and etc. Combined with batteries, the NTU-1200 is suitable for use in residential, commercial, marine, automobile, mine, construction site, and remote areas with no access to utility power, and the output can be used to power fans, TV, radio, phone charger, PC/laptop, lighting, induction stove, air conditioner, electromechanical tool, communication equipment, power distribution cabinet, outdoor camping equipment, marine AC power, factory equipment, and etc.

Model Encoding

NTU - 1200 - **1** **12** **US**

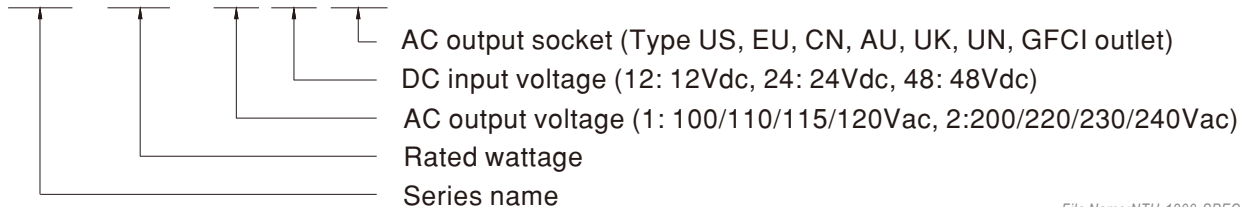

SPECIFICATION

MODEL NO.		NTU-1200-112 <input type="checkbox"/>	NTU-1200-124 <input type="checkbox"/>	NTU-1200-148 <input type="checkbox"/>	NTU-1200-212 <input type="checkbox"/>	NTU-1200-224 <input type="checkbox"/>	NTU-1200-248 <input type="checkbox"/>		
		<input type="checkbox"/> = US, GFCI, UN			<input type="checkbox"/> = EU, CN, AU, UK, UN				
AC OUTPUT	RATED POWER(Continuous)	1200W							
	OVER RATED POWER(3 Min.)	1380W							
	PEAK POWER(10 Sec.)	1800W							
	SURGE POWER(30 Cycles)	2000W							
	AC VOLTAGE	Default setting set at 110VAC 100 / 110 / 115 / 120Vac selectable by DIP S.W			Default setting set at 230VAC 200 / 220 / 230 / 240Vac selectable by DIP S.W				
	FREQUENCY	Default setting set at 60±0.1Hz 50/60Hz selectable by DIP S.W			Default setting set at 50±0.1Hz 50/60Hz selectable by DIP S.W				
	WAVEFORM <small>Note.1</small>	True sine wave (THD<3%)							
	AC REGULATION	±3.0% at rated output voltage							
FRONT PANEL LED	Please see page 5								
DC INPUT	DC VOLTAGE	12Vdc	24Vdc	48Vdc	12Vdc	24Vdc	48Vdc		
	VOLTAGE RANGE (Typ.)	10 ~ 16.5Vdc	20 ~ 33Vdc	40 ~ 66Vdc	10 ~ 16.5Vdc	20 ~ 33Vdc	40 ~ 66Vdc		
	DC CURRENT (Typ.)	120A	60A	30A	120A	60A	30A		
	NO LOAD DISSIPATION (Typ.)	NON-SAVING MODE	15W			25W			
		SAVING MODE	Default disable, auto detect AC output load ≤ 10W will be changed to saving mode <8W						
	OFF MODE CURRENT DRAW	≤ 1mA							
	EFFICIENCY (Typ.) <small>Note.1</small>	89%	90%	91%	90%	92%	93%		
BATTERY TYPES	Lead Acid or li-ion								
PROTECTION	DC INPUT	FUSE (INTERNAL)	40A*4	40A*2	25A*2	40A*4	40A*2	25A*2	
		LOW	ALARM	11±0.3Vdc	22±0.5Vdc	44±1Vdc	11±0.3Vdc	22±0.5Vdc	44±1Vdc
			SHUTDOWN	10±0.3Vdc	20±0.5Vdc	40±1Vdc	10±0.3Vdc	20±0.5Vdc	40±1Vdc
			RESTART	12.5±0.3Vdc	25±0.5Vdc	50±1Vdc	12.5±0.3Vdc	25±0.5Vdc	50±1Vdc
		HIGH	ALARM	15.5±0.3Vdc	31±0.5Vdc	62±1Vdc	15.5±0.3Vdc	31±0.5Vdc	62±1Vdc
			SHUTDOWN	16.5±0.3Vdc	33±0.5Vdc	66±1Vdc	16.5±0.3Vdc	33±0.5Vdc	66±1Vdc
	RESTART		15±0.3Vdc	30±0.5Vdc	60±1Vdc	15±0.3Vdc	30±0.5Vdc	60±1Vdc	
	BAT. POLARITY		By internal fuse open						
	AC OUTPUT	OVER TEMPERATURE	Protection type : Shut down o/p voltage, re-power on to recover						
		OUTPUT SHORT	Protection type : Shut down o/p voltage, re-power on to recover						
		OVER LOAD (Typ.)	105 ~ 115% load for 180 sec., 115% ~ 150% load for 10 sec. Protection type : Shut down o/p voltage, re-power on to recover						
		CIRCUIT BREAKER	15A			10A			
GFCI PROTECTION		UL458 (Only for "GFCI" AC socket, by request)			None				
FUNCTION	REMOTE CONTROL	CONNECTOR ACCESSORY	Power ON-OFF remote control by front panel dry contact connector(by RELAY), Open : Normal work ; Short : Remote off Remote controller sold separately, Order No.: IRC1,IRC2,IRC3						
	RS-232 COMMUNICATION		RS-232 ~ RJ11 Type connector (Please refer to page 4 for more details)						
AC UPS MODE	AC INPUT RANGE	100/110/115/120Vac±16%, recover±13%			200/220/230/240Vac±16%, recover±13%				
	FREQUENCY RANGE	45 ~ 65Hz							
	TRASFER TIME(Typ.)	10ms inverter → AC by pass							
ENVIRONMENT	WORKING TEMP.	-25 ~ +70°C (Refer to "Derating curve")							
	WORKING HUMIDITY	20% ~ 90% RH non-condensing							
	STORAGE TEMP., HUMIDITY	-30 ~ +70°C / -22 ~ +158°F, 10 ~ 95% RH non-condensing							
	VIBRATION	10 ~ 500Hz, 3G 10min./1cycle, 60min. each along X, Y, Z axes							
SAFETY & EMC <small>(Note.4)</small>	SAFETY STANDARDS		CB IEC62368-1, Dekra BS EN/EN62368-1, UL458, E13, EAC TP TC 004 approved; Design refer to AS/NZS 62368.1 (Please refer to next page "AC output socket" table for more details)						
	WITHSTAND VOLTAGE		DC I/P - AC I/P:3.0KVac DC I/P - AC O/P:3.0KVac AC O/P - FG:1.5KVac						
	EMC EMISSION	Radiated	Parameter	Standard			Test Level / Note		
				FCC for 112, 124, 148 only(expect for Type-UN)			Class A		
		Conducted		BS EN/EN55032(CISPR32) for 212, 224, 248 only(expect for Type-UN)			Class A		
				FCC for 112, 124, 148 only(expect for Type-UN)			Class A		
		Harmonic Current		BS EN/EN61000-3-2			Class A		
		Voltage Flicker		BS EN/EN61000-3-3			-----		
	EMC IMMUNITY			BS EN/EN55024, BS EN/EN55035					
			Parameter	Standard			Test Level / Note		
			ESD	BS EN/EN61000-4-2			Level 3, 8KV air ; Level 2, 4KV contact		
			Radiated	BS EN/EN61000-4-3			Level 2		
		EFT / Burst	BS EN/EN61000-4-4			Level 2, 1KV			
		Surge	BS EN/EN61000-4-5			Level 3, 1KV/Line-Line 2KV/Line-Earth			
		Conducted	BS EN/EN61000-4-6			Level 2			
		Magnetic Field	BS EN/EN61000-4-8			Level 1			
	Voltage Dips and Interruptions	BS EN/EN61000-4-11			>95% dip 0.5 periods, 30% dip 25 periods, >95% interruptions 250 periods				
OTHERS	MTBF	460.5K hrs min. Telcordia TR/SR-332 (Bellcore) ; 58.3K hrs min. MIL-HDBK-217F (25°C)							
	DIMENSION	333*184*70mm (L*W*H)							
	PACKING	3.3Kg; 2pcs/ 7.6Kg/ 1.25CUFT							
NOTE	<p>1.Efficiency, AC regulation and THD are tested by 900W load, linear load at 12.5Vdc/25Vdc/50Vdc input voltage.</p> <p>2.All parameters not specified above are measured at rated load, 25°C of ambient temperature and set to factory setting.</p> <p>3.Internal pre-start circuit, the setup time is 8s.</p> <p>4.The power supply is considered as an independent unit, but the final equipment still need to re-confirm that the whole system complies with the EMC directives. For guidance on how to perform these EMC tests, please refer to "EMI testing of component power supplies." (as available on https://www.meanwell.com/Upload/PDF/EMI_statement_en.pdf)</p> <p>※ Product Liability Disclaimer : For detailed information, please refer to https://www.meanwell.com/serviceDisclaimer.aspx</p>								

AC Output Socket

MODEL NO.	NTU-1200-112 <input type="checkbox"/>	NTU-1200-124 <input type="checkbox"/>	NTU-1200-148 <input type="checkbox"/>	NTU-1200-212 <input type="checkbox"/>	NTU-1200-224 <input type="checkbox"/>	NTU-1200-248 <input type="checkbox"/>		
Socket type								
	TYPE-US	TYPE-GFCI	TYPE-UN	TYPE-EU	TYPE-CN	TYPE-UK	TYPE-AU	TYPE-UN
	In Stock	By request	In Stock	In Stock	In Stock	By request	By request	In Stock
Country	USA	USA	UNIVERSAL	EUROPE	CHINA	U.K	AUSTRALIA	UNIVERSAL
Certificate			None					

DERATING CURVE

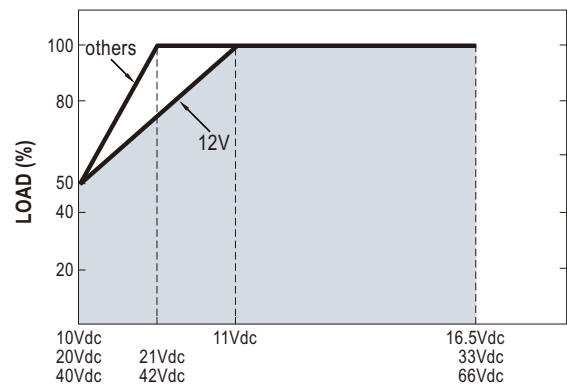
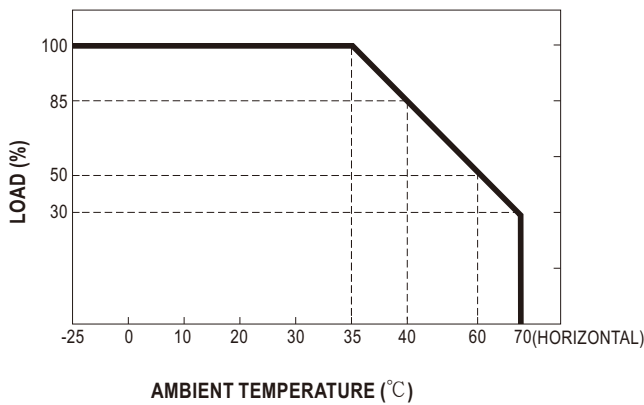

Block Diagram

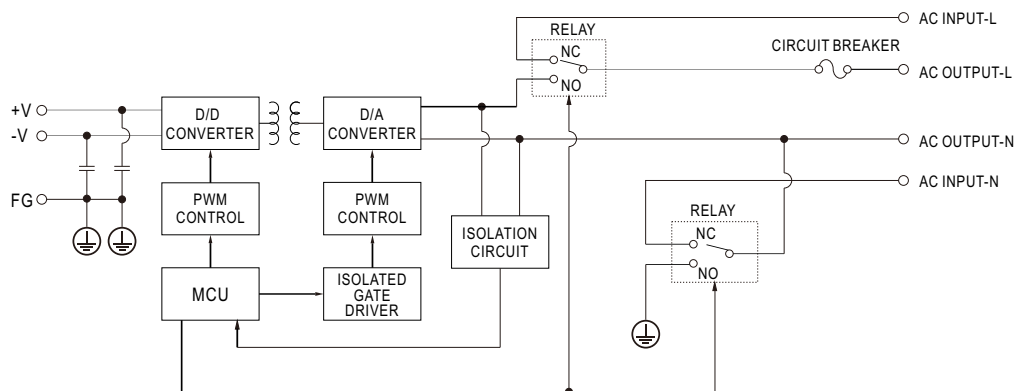

Note:

1. The inverter operates in AC bypass mode when the AC input is connected and remains within $\pm 16\%$ of the AC output setting. During this mode, energy from the AC input is directly supplied to the loads. Conversely, the inverter switches to inverter mode when there is no AC input available or the AC input exceeds $\pm 16\%$ of the AC output setting.
2. The relationship between the AC receptacle Earth and AC output-N is shown in the table below.
3. The AC receptacle earth and FG are electrically identical in the hardware and are shorted together.
4. The bypass relays remain in NC position when the inverter is turned off. As a result, energy from the AC input can still pass through the inverter to the loads, operating as in the AC bypass mode.

Operating Mode	Connection Status Between AC Output and AC Receptacle Earth
Inverter Mode (Battery input)	The AC Output-N pin, AC Receptacle Earth and FG are shorted internally
Bypass Mode (AC mains input)	The AC Receptacle Earth and FG are shorted internally. AC Output-L/N depends on AC mains input

IRC1/2/3 Remote Controller (Accessory sold separately)

- IRC1/IRC2/IRC3 is the monitoring and control unit.
- IRC1/IRC2/IRC3 can decode the RS-232 signals sent by the inverter series and display through digital meters.

Note: Part of the control signals will not function properly due to different compliance of each model.

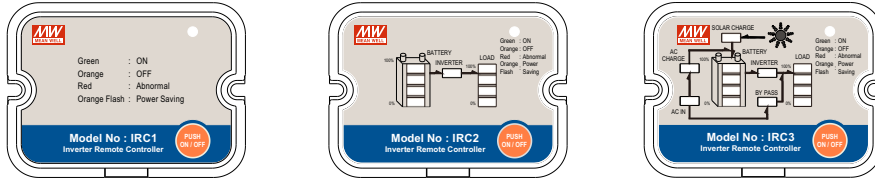

※ Please refer to for more detail: <https://www.meanwell.com/webapp/product/search.aspx?prod=IRC1>

Support RS-232 Communication

- The internal data of single NTU-1200 can be read through RS-232.

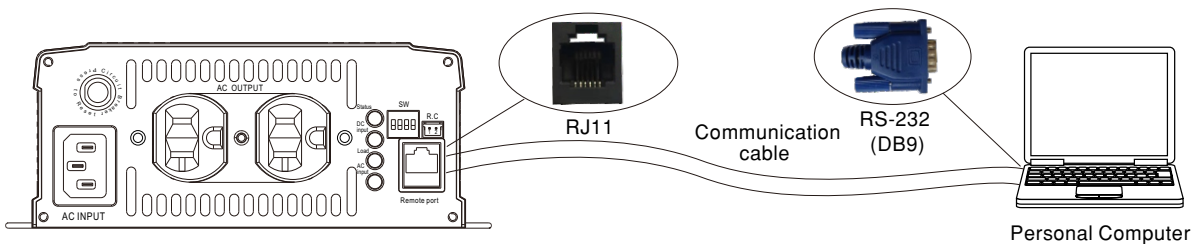

※ Please refer to for more detail: <http://www.meanwell.com/manual.html>

※ RJ11-RS232 Communication cable should be ordered separately, Order No.: RJ11-RS232

Remote ON-OFF Control (Built-in)

Remote ON-OFF	AC Output Status
Open	power inverter ON
Short	power inverter OFF

AC Output Voltage, Frequency, Power saving mode selectable by DIP SW

Output voltage and frequency setting factory settings are either 110Vac/60Hz or 230Vac/50Hz, users are able to adjust the voltage and frequency, through the DIP switch of position 1,2,3,4 on the panel.

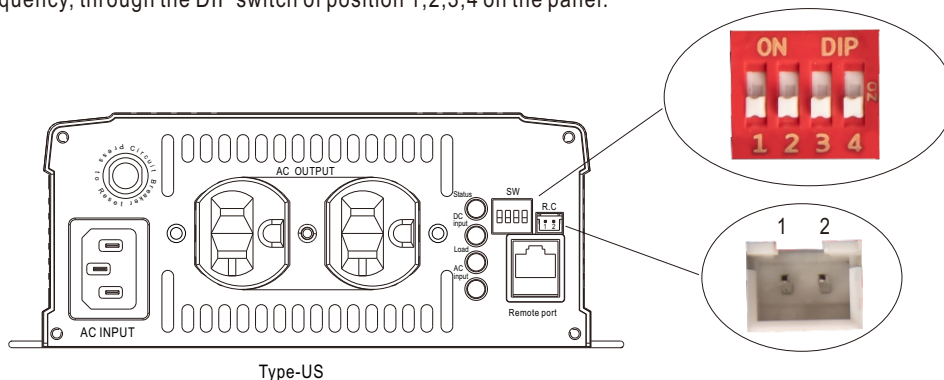

Type-US

AC Output Voltage, Frequency, Power saving mode selectable by DIP SW

SW1	SW2	SW3	SW4
OFF	OFF : 100Vac or 200Vac	ON : 50Hz	ON : Saving mode
OFF	ON : 110Vac or 220Vac		
ON	OFF : 115Vac or 230Vac	OFF: 60Hz	OFF: Non-Saving mode
ON	ON : 120Vac or 240Vac		

■ LED STATUS

Normal work:

	Green	Orange	Red
Status	System check	Remote off	Abnormal Status (See below table)
	Inverter OK	Saving mode	

	Green	Orange	Red
DC Input	12.5~15.5Vdc	11~12.5Vdc	<11Vdc or >15.5Vdc
	25~31Vdc	22~25Vdc	<22Vdc or >31Vdc
	50~62Vdc	44~50Vdc	<44Vdc or >62Vdc

Mains Priority status:

	Green	Orange	Red
Load	<40% load	40~80% load	>80% load

Battery Priority status:

	Green	Orange	Red
Load	<40% load	40~80% load	>80% load

	Green	Orange	Red
AC Input	Mains OK	-----	-----
	Mains error	-----	-----
	Mains disconnected		

Abnormal status :







LED Indicator	Abnormal Indication
Status DC Input Load	Output overload or AC output short circuit
Status DC Input Load	Abnormal DC voltage
Status DC Input Load	Over temperature or Fan lock
Status DC Input Load	Inverter fail

- Light
- Light off
- Flash



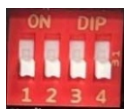





■ **FUNCTION MANUAL**

Battery /Mains Priority Setting (factory setting mains priority)

1. DIP S.W setting battery priority mode

Step	Action	Note
A1	When the power is not being sent, turn the 2 and 3 DIP switches of the selected DIP_SW to the "OFF" state	
A2	BAT power supply in remote off mode	
A3	Within 15 seconds of power transmission, switch 2 and 3 of the DIP_SW to full "ON", and then switch back to full "OFF"	 → 
A4	All LEDs (except AC input) flash green 3 times, indicating that the setting is successful	
A5	Turn off NTU and turn on the external Remote switch	 → 
A6	Turn on NTU to load battery priority mode	

2. DIP S.W setting mains priority mode

Step	Action	Note
A1	When the power is not being sent, turn the 2 and 3 DIP switches of the selected DIP_SW to the "ON" state	
A2	BAT power supply in remote off mode	
A3	Within 15 seconds of power transmission, switch 2 and 3 of the DIP_SW to full "OFF", and then switch back to full "ON"	 → 
A4	All LEDs (except AC input) flash green 3 times, indicating that the setting is successful <i>(Only clear battery priority mode, don't restore factory setting)</i>	
A5	Turn off NTU and turn on the external Remote switch	 → 
A6	Turn on NTU to load mains priority mode	

MECHANICAL SPECIFICATION

(Unit: mm , tolerance ± 1 mm)

Case No. 286A

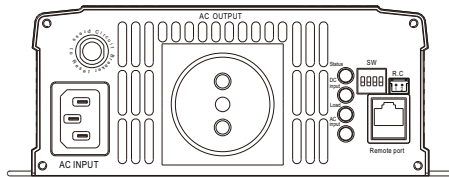
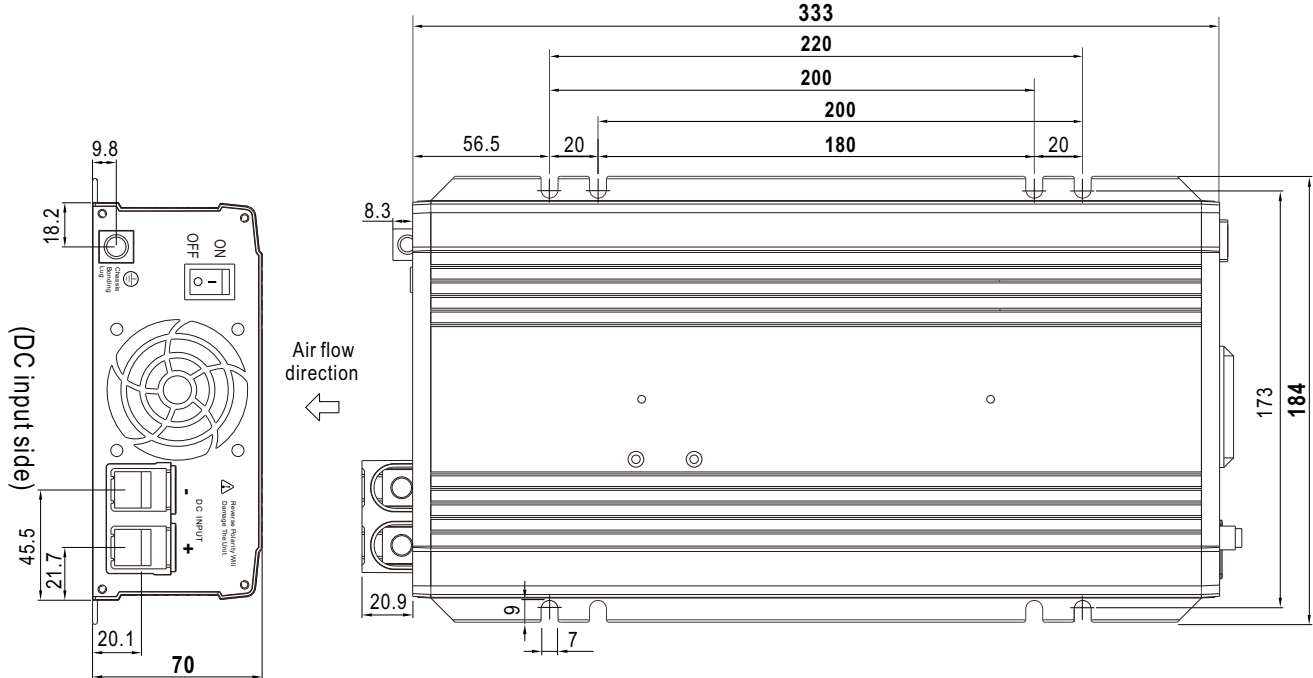

Type-EU

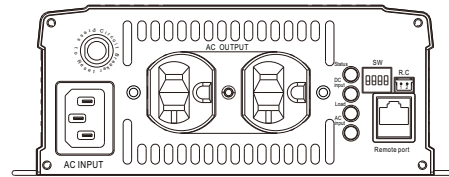

Type-US

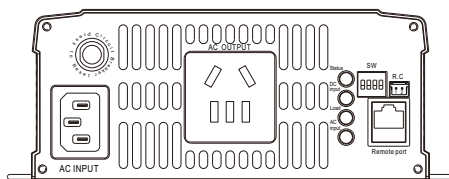

Type-CN

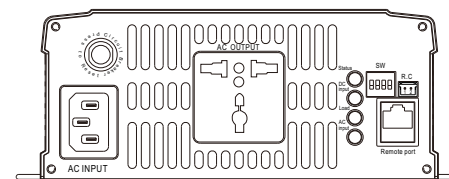

Type-UN

(AC output side)

R.C Connector : JST B-XH or equivalent

Remote Control	Mating Housing	Terminal
Pin 1,2 Open: Normal work	JST XHP or equivalent	JST SXH-001T or equivalent
Pin 1,2 Short: Remote off		

Remote port connector (RJ11)



Remote port



Assignment	Rx	GND	Tx
Remote port	2	3	4
DB9	3	5	2

■ **Accessory List**

※ Communication cable (Optional accessory, Power inverter and Communication cable should ordered seperately)

MW's Order No.	Item	Quantity
RJ11-RS232		1

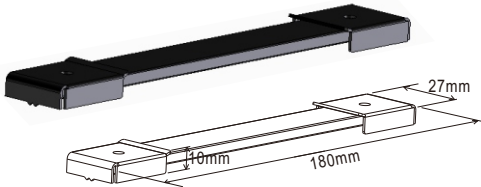
※ Carry handle (Optional accessory, Power inverter and Pull handle should ordered seperately)

MW's Order No.	Item	Quantity
Carry Handle	①  Handle	1
	②  Foot pad	4
	③  Screw	2

① Handle

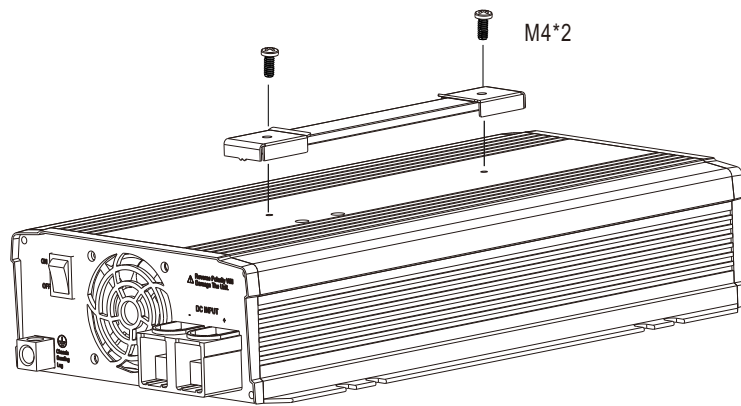

② Foot pad

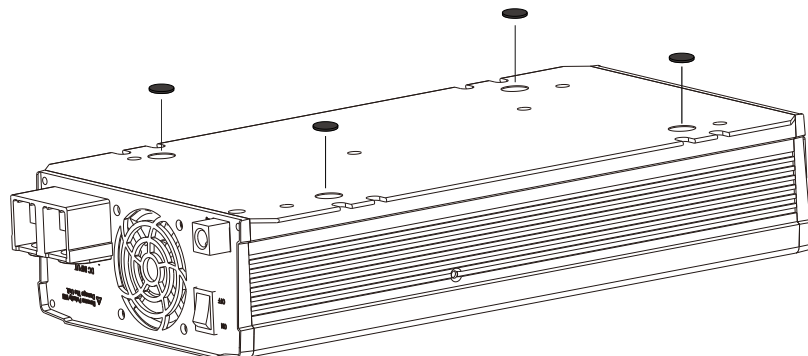

■ TYPICAL APPLICATION



- 1 Battery Bank
- 2 Off-Grid DC/AC Solar Inverter (NTU series)
- 3 AC Outlet



- 1 Utility Input (Shore)
- 2 AC/DC Battery Charger (PB/NPB/NPP series)
- 3 Battery Bank
- 4 Off-Grid DC/AC Power Inverter (NTU series)
- 5 AC Outlet

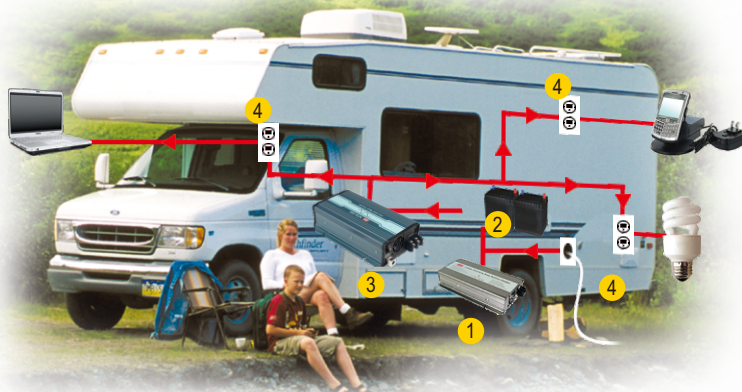

- 1 AC/DC Battery Charger (PB/NPB/NPP series)
- 2 Battery Bank
- 3 Off-Grid DC/AC Inverter (NTU series)
- 4 AC Outlet

■ INSTALLATION MANUAL

Please refer to : <http://www.meanwell.com/manual.html>