

REV	ECN No.	DATE	REMARK
J	NEW	2024.05.25	增加重点尺寸标识

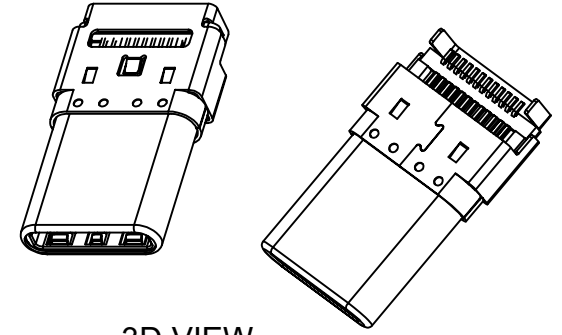

3D VIEW

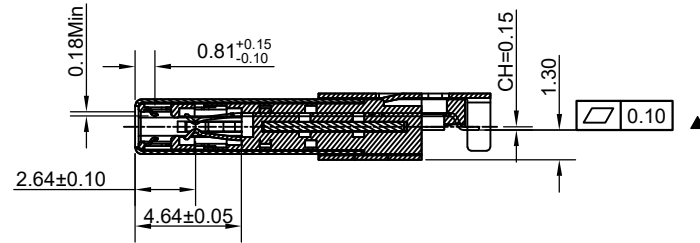
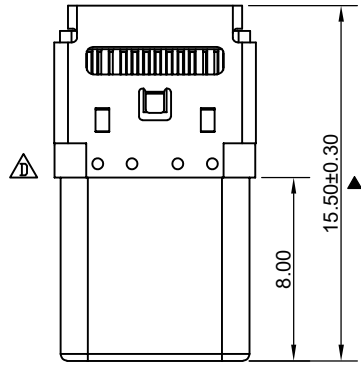
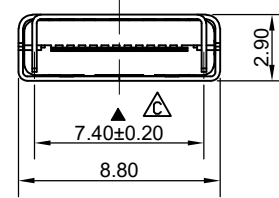
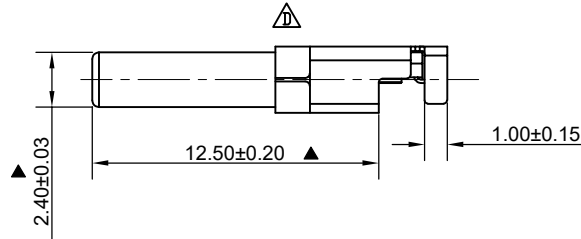
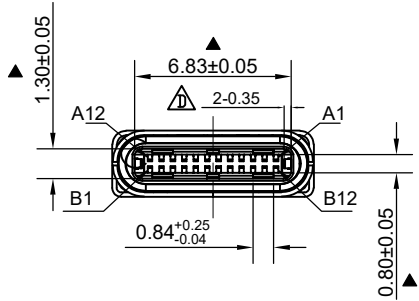

SECTION: A-A

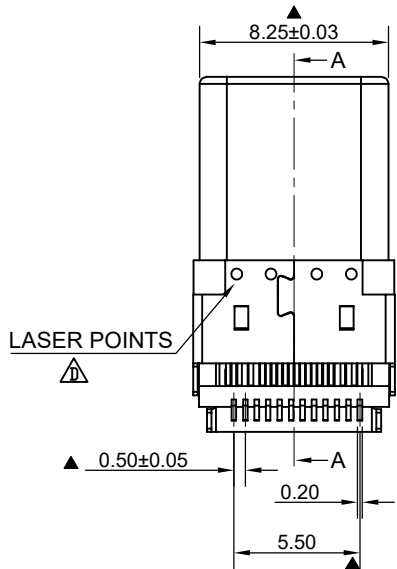

带塞子尺寸示意图

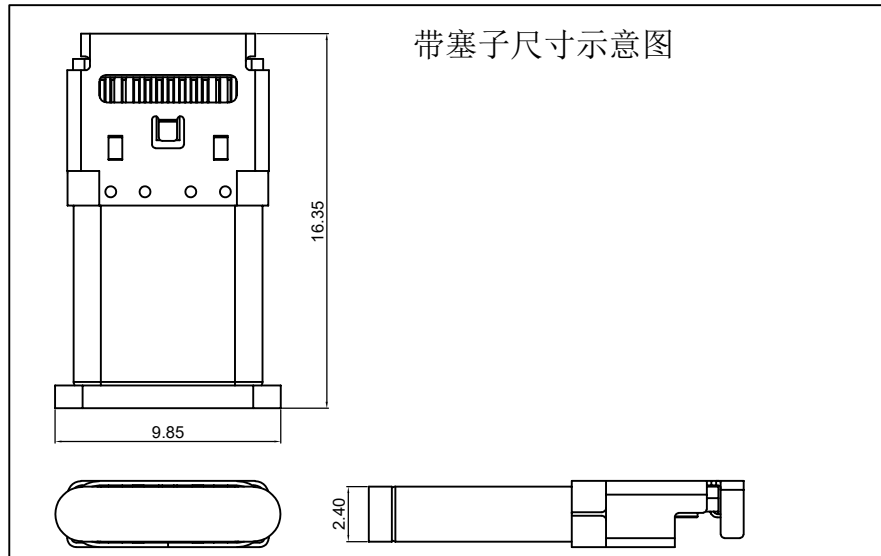
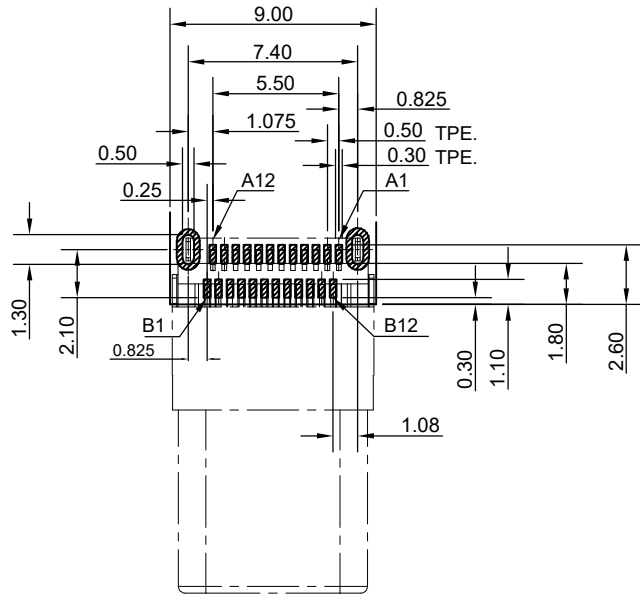

Table:

ITEM	NAME	QTY.	MATERIAL	DESCRIPTION			
7	CAP	1	LCP UL94V-0	Color: Black			
6	Shield	1	Stainless Steel SUS304	Nickel Plating			
5	Housing	4	LCP UL94V-0	Color: Black /Orange 172			
4	Latch	1	Stainless Steel SUS301				
3	Contact	24	Copper Alloy C7025	3u"/15u"gold plated on Contact area, Matte Tin plated on Solderetails, Nickel underplating over all			
2	Emc Spring	2	Stainless Steel SUS304				
1	Shell	1	Stainless Steel SUS316L	Nickel Plating			
GENERAL TOLERANCES (UNLESS SPECIFIED)	DRAWN BY: HuangXiaoHao		Date: 2024.05.25	ZDT 深圳市中科兴达科技有限公司 Shenzhen Zhongke Xingda Technological Co.,Ltd. TITLE USB TYPE-C PLUG SMT MIDDLE MOUNT RIGHT ANGLE L=15.5MM PART NO. CM073-24LB02RC-C-68 DWG NO. CM073-24-68			
X.XXX	±0.10	CHECKED BY: liuzongliang	Date: 2024.05.25				
X.XX	±0.25	APPROVED BY: Jacky	Date: 2024.05.25				
X.X	±0.30						
ANGULAR	±3°	THIRD ANGLE PROJECTION	UNT mm	SCALE 1:1	DRAWING A4	SHEET NO. 1 OF 3	REV. A

REV	ECN No.	DATE	REMARK
J	NEW	2024.05.25	增加重点尺寸标识



RECOMMENDED P.C.B. LAYOUT
T=0.80 OR 1.00mm

TOLERANCE UNSPECIFIED ±0.05mm

Note:

- Electrical Characteristics:
Current Rating: 5A For Pin(A4,A9,B4,B9)
1.25A For Others Pin
Insulation Resistance: 100MΩ Min.
Contact Resistance: 40 mΩ Max.
Dielectric Withstanding Voltage:100V/AC 1Minute
- Mechanical Characteristics:
Insertion Force: 5~20N
Extraction Force: Initial: 8~20N
After durability: 6~20N
Durability :10000 Cycles
- Salt Spray :24H/48H
- Operating Temperature: -30°C TO +85°C
- Meet ROHS & HF Requirements.
- With "▲" For the key Control Size

TID No.	2154
IEC No.	24B01N001454-001-COM

Ordering Information:

▲ CM073-24 $\frac{X}{1}$ L $\frac{B}{2}$ $\frac{XX}{3}$ $\frac{X}{4}$ $\frac{C}{5}$ - $\frac{X}{6}$ - 68

- Shell Plated:
(Blank): Nickel Plating
J: Black Nickel Plating
- Housing Color:
B:Black
O:Orange 172色
- Contacts Plated:
02:Contact Area: Au 3u",Solder Tails:Tin
04:Contact Area: Au 15u",Solder Tails:Tin
05:Contact Area: Au 30u",Solder Tails:Tin
- Packing Options:
R:Tape & Reel
VR:Tape & Teel+Vacuum Packaging
- Without/With CAP Options:
(Blank): Without CAP
C: With CAP(Common material)
- Salt Spray: ▲
(Blank):Salt Spray24H
C:Salt Spray 48H

USB TYPE-C PIN ASSIGNMENTS

PIN NUMBER	SIGNAL NAME	PIN NUMBER	SIGNAL NAME
A1	GND	B12	GND
A2	SSTXp1	B11	SSRXp1
A3	SSTXn1	B10	SSRXn1
A4	V _{BUS}	B9	V _{BUS}
A5	CC1	B8	SBU2
A6	Dp1	B7	Dn2
A7	Dn1	B6	Dp2
A8	SBU1	B5	CC2
A9	V _{BUS}	B4	V _{BUS}
A10	SSRXn2	B3	SSTXn2
A11	SSRXp2	B2	SSTXp2
A12	GND	B1	GND

GENERAL TOLERANCES (UNLESS SPECIFIED)	DRAWN BY: HuangXiaoHao	Date: 2024.05.25	ZDT 深圳市中科兴达科技有限公司 Shenzhen Zhongke Xingda Technological Co.,Ltd.		
X.XXX	±0.10	CHECKED BY: liuzongliang	Date: 2024.05.25	TITLE USB TYPE-C PLUG SMT MIDDLE MOUNT RIGHT ANGLE L=15.5MM	
X.XX	±0.25	APPROVED BY: Jacky	Date: 2024.05.25	PART NO. CM073-24LB02RC-C-68	DWG NO. CM073-24-68
X.X	±0.30	THIRD ANGLE PROJECTION	UNT mm	SCALE 1:1	DRAWING A4
ANGULAR	±3°			SHEET NO. 2 OF 3	REV. J

REV	ECN No.	DATE	REMARK
J	NEW	2024.05.25	增加重点尺寸标识

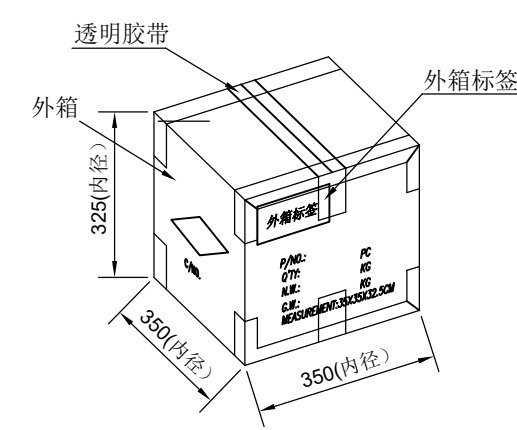
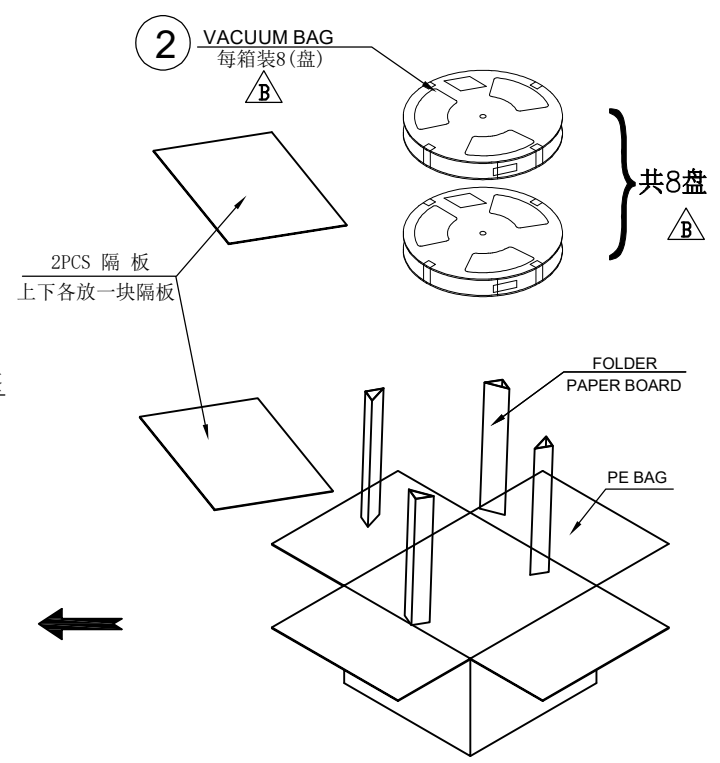
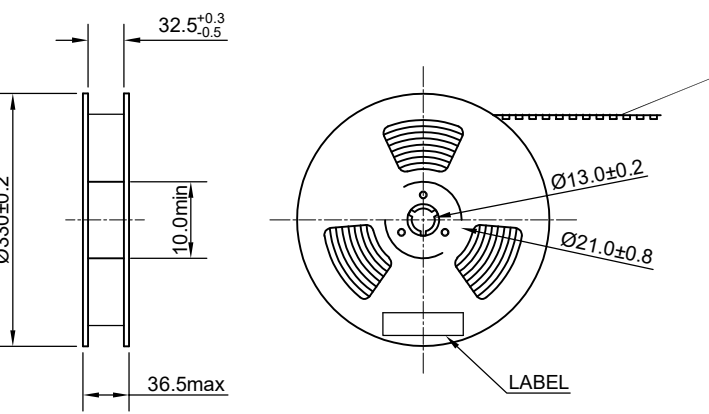
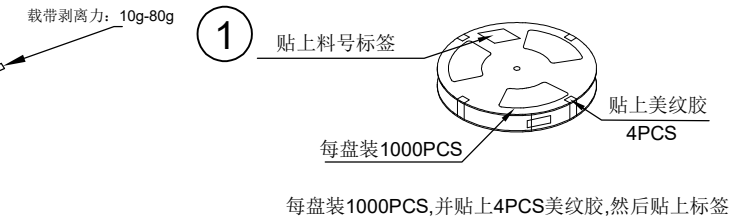
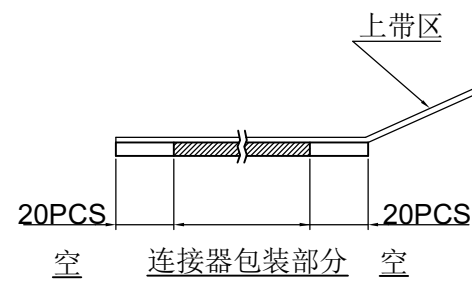
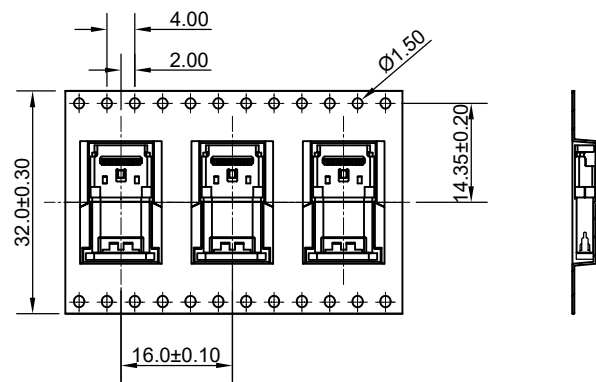

外箱尺寸为内径, 单位:mm

- 备注:
- 包材规格:
蓝色卷盘: Ø330*W32mm(P/N:PA330330032-01U)
卷带料号: PR016032005-07S,(1044PCS空格/卷).
三角纸板: 100*140*100mm,H=315mm,K=K(P/N.:PK100100315-01K)
自粘上带: W=25.5mm, T=0.08mm (P/N:PM000255008-003)
外箱: 35*35*32.5cm(P/N:PK350350325-01K)
 - 将产品依上图所示装入载带中, 再将自粘上带与载带粘好,注意不可封孔, 上带需比载带长至少300mm, 然后用80-150mm美纹胶固定; 1000pcs/卷盘, 每卷盘都需贴卷盘物料标签.
 - 外箱底部先垫一隔板,并在外箱四个内角各放置一个三角架, 把8卷(8000PCS)封装好的产品标签一律朝上平放进外箱中 上层盖上一隔板, 再用封箱胶纸将外箱口於“工”字型封好.
 - 载带剥离力: 10g-80g

GENERAL TOLERANCES (UNLESS SPECIFIED)		DRAWN BY: HuangXiaoHao		Date: 2024.05.25		ZDT 深圳市中科兴达科技有限公司 Shenzhen Zhongke Xingda Technological Co.,Ltd.	
X.XXX	±0.10	CHECKED BY: liuzongliang		Date: 2024.05.25		TITLE USB TYPE-C PLUG SMT MIDDLE MOUNT RIGHT ANGLE L=15.5MM	
X.XX	±0.25	APPROVED BY: Jacky		Date: 2024.05.25		PART NO. CM073-24L B02RC-C-68	
X.X	±0.30	THIRD ANGLE PROJECTION		UNT mm		SCALE 1:1	
ANGULAR	±3°	DRAWING		SHEET NO. 3 OF 3		DWG NO. CM073-24-68	
		REV.		J			

PART NO.	REEL/TRAY	CARTON	净重 (KG)	毛重 (KG)	外箱尺寸
XXXX-XX-X	1000	8000			L=350mm*W=350mm*H=325mm