

GENERAL DESCRIPTION:

The STLV70033DDCR series is a set of low voltage differential (LDO) converters with a wide voltage input range of 2.0V to 5.5V, low voltage differential, low power consumption, and miniaturized packaging. The output voltage range is 1.2-3.6V, and the STLV700XXDDCR has low static current characteristics as low as 70uA. The circuit also has a CE enable control port, which can put the circuit into sleep mode. It is particularly suitable for battery powered and long-term standby system equipment applications, helping to reduce standby power consumption of system equipment, effectively extending standby time and battery life.

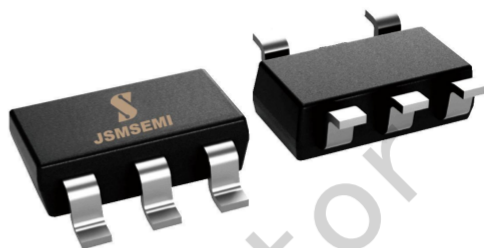

SOT23-5

FEATURES:

- ◆ Low Power Consumption
- ◆ Low Voltage Drop
- ◆ 1- μ A Max IQ in Shutdown Mode
- ◆ Withstanding Voltage 5.5V
- ◆ Quiescent Current 65 μ A
- ◆ Output Voltage Accuracy: tolerance $\pm 2\%$
- ◆ High output current: 250mA

PIN CONFIGURATION

TYPICAL APPLICATIONS

- ◆ Battery-powered Equipments
- ◆ Communication Equipments
- ◆ Audio/Video Equipments

ORDERING INFORMATION

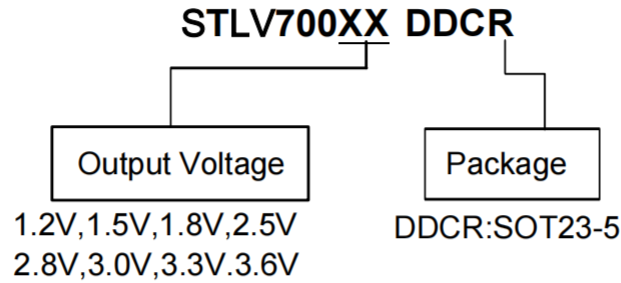

PIN DESCRIPTION

| PIN No. | Name | Functions Description |
|---------|------|-----------------------|
| 1 | VIN | input |
| 2 | VSS | ground |
| 3 | CE | ON / OFF Control |
| 4 | NC | No Connect |
| 5 | VOUT | output |

FUNCTIONAL BLOCKDIAGRAM

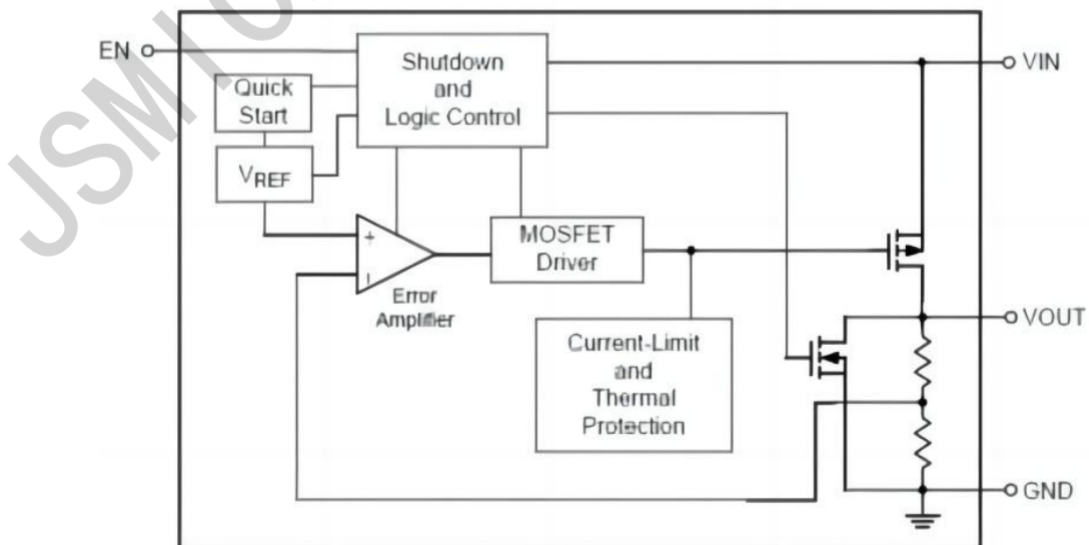

ABSOLUTE MAXIMUM RATINGS

| Description | Symbol | Value range | Unit |
|--------------------------------------|-----------|-------------|------|
| Limit Power Voltage | V_{IN} | -0.3~+6.0 | V |
| Storage Temperature Range | T_{STG} | -50~+125 | °C |
| Operating Free-air Temperature Range | T_A | -25~+85 | °C |

Note : Stresses greater than those listed under “Absolute Maximum Ratings” may cause permanent damage to the device. These are stress ratings only, and functional operation of the device at these or any other conditions beyond those indicated under “Recommended Operating Conditions” is not implied. Exposure to “Absolute Maximum Ratings” for extended periods may affect device reliability.

HEAT DISSIPATION

| Description | Symbol | Package | Value range | Unit |
|--------------------|---------------|---------|-------------|------|
| Thermal resistance | θ_{JA} | SOT23-5 | 500 | °C/W |
| Power dissipation | P_W | SOT23-5 | 200 | mW |

DC CHARACTERISTICS(unless otherwise noted $T_A = +25^\circ\text{C}$)

| Parameter | Symbol | Test Condition | Min | Typ | Max | Unit |
|------------------------------|--|--|-----|------|-----|---------------------|
| Input Voltage | V_{IN} | | | | 5.5 | V |
| Output Voltage | V_{OUT} | | 1.2 | | 3.6 | V |
| Voltage Accuracy | | $I_{OUT} = 1\text{mA}$ | -2 | | +2 | % |
| Output Current | I_{OUT} | $V_{IN} = V_{OUT} + 2.0\text{V}$ | — | 250 | — | mA |
| Load Regulation | ΔV_{OUT} | $V_{IN} = V_{OUT} + 2.0\text{V}$ $1\text{mA} \leq I_{OUT} \leq 100\text{mA}$ | — | 100 | — | mV |
| Line Regulation | $\frac{\Delta V_{OUT}}{V_{OUT}} / \Delta V_{IN}$ | $V_{OUT} + 1.0\text{V} \leq V_{IN} \leq 8\text{V}$ $I_{OUT} = 40\text{mA}$ | — | 0.05 | — | %/V |
| Voltage Drop | $V_{DIF}^{\text{①}}$ | $I_{OUT} = 100\text{mA}, V_{OUT} = 3.3\text{V}$ | — | 90 | — | mV |
| Quiescent Current | I_{SS} | $V_{CE} = V_{IN}$ | — | 65 | — | μA |
| Standby Current | $I_{STANDBY}$ | $V_{CE} = V_{SS}$ | — | 1.0 | — | μA |
| -- | V_{CEH} | | 1.1 | | | V |
| -- | V_{CEL} | | | | 0.4 | V |
| short-circuit current | I_{SHORT} | $V_{IN} = V_{OUT} + 2.0\text{V}$ | — | 400 | — | mA |
| Output noise voltage | V_{en} | $I_{OUT} = 40\text{mA}$, 300Hz ~ 50kHz | | 50 | | μV_{rms} |
| Power-supply Rejection ratio | PSRR | $V_{IN} = [V_{out} + 1]\text{V} + 1\text{V}_{p-pAC}$ $I_{OUT} = 40\text{mA}, f = 1\text{kHz}$ | — | 70 | — | dB |

Note : When $V_{IN} = V_{OUT} + 2.0\text{V}$, as the output voltage declined 2%, the $V_{DIF} = V_{IN} - V_{OUT}$.

Output active discharge resistor R_{DIS} , As the input voltage increases, it decreases.

FUNCTIONAL DESCRIPTION

STLV70033DDCR are linear voltage regulator ICs withstanding 5.5V voltage. The IC consists of a voltage reference, an error amplifier, a current limiter and a phase compensation circuit plus a driver transistor. The output stabilization capacitor is also compatible with low ESR ceramic capacitors.

The over current protection circuit and the over voltage protection circuit are built-in. The protection circuit will operate when the output current or input voltage reaches limit level.

TYPICAL APPLICATION CIRCUIT

Basic Circuit

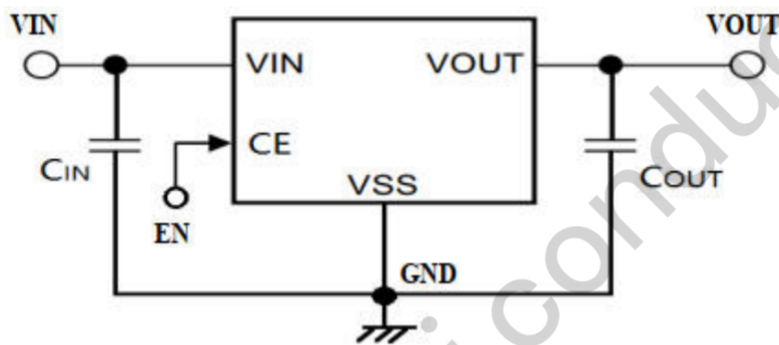

TYPICAL CHARACTERISTICS

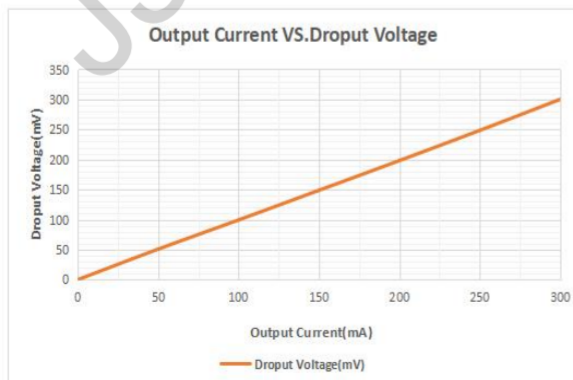
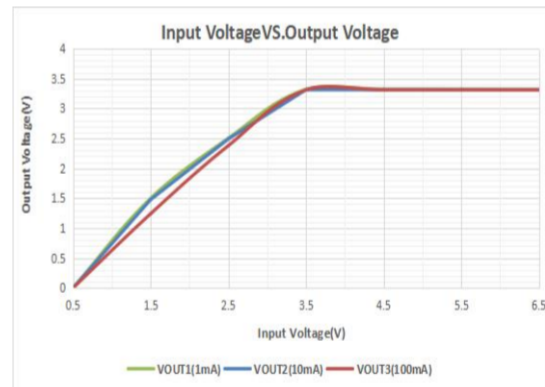
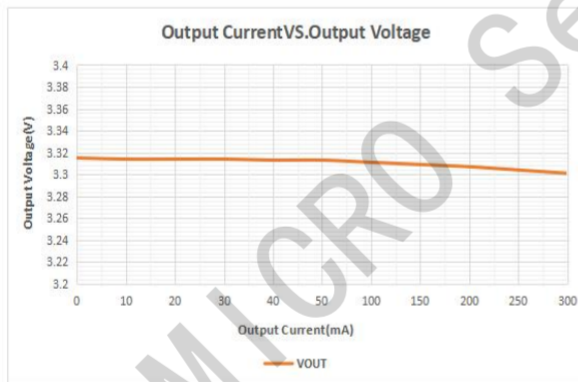

SOT23-5

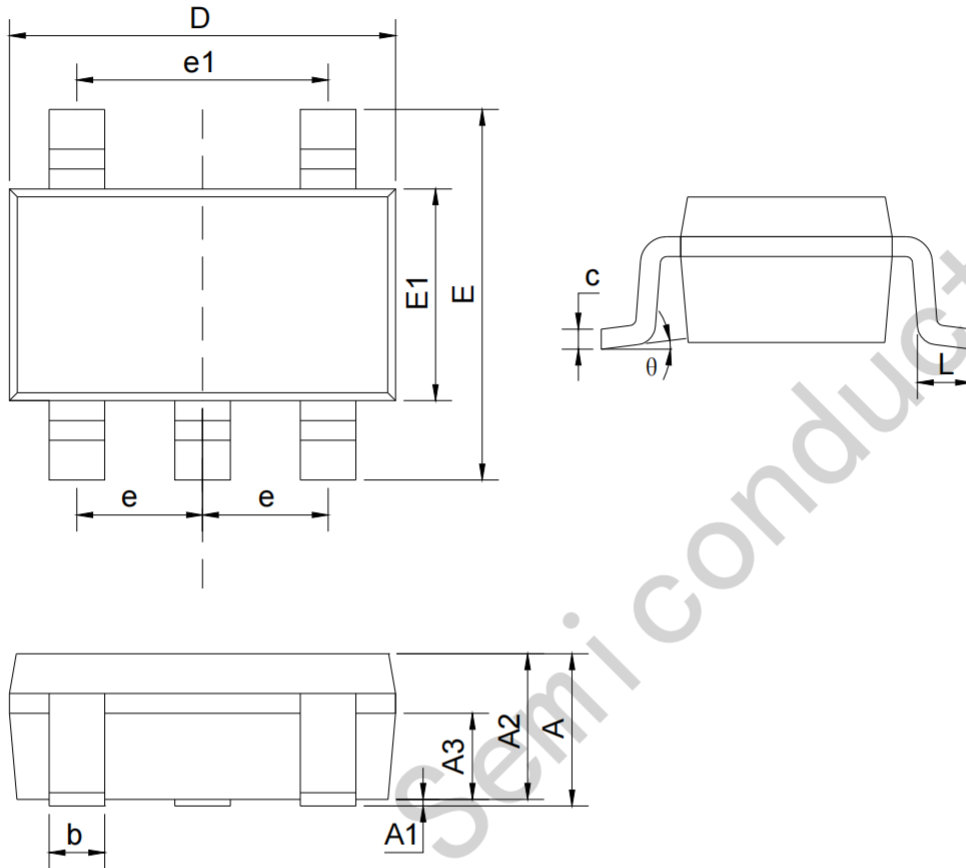

| SYMBOL | mm | |
|--------|---------|------|
| | min | max |
| A | | 1.35 |
| A1 | 0.04 | 0.15 |
| A2 | 1.00 | 1.20 |
| A3 | 0.55 | 0.75 |
| b | 0.38 | 0.48 |
| c | 0.10 | 0.25 |
| D | 2.72 | 3.12 |
| E | 2.60 | 3.00 |
| E1 | 1.40 | 1.80 |
| e | 0.95BSC | |
| e1 | 1.90BSC | |
| L | 0.30 | 0.60 |
| θ | 0 | 8° |