

Product Summary

- V_{DS} 100V
- I_D 140A
- $R_{DS(ON)}$ (at $V_{GS}=10V$) <4.2m Ω
- 100% EAS Tested
- 100% ∇V_{DS} Tested

General Description

- Split gate trench MOSFET technology
- Excellent package for heat dissipation
- High density cell design for low $R_{DS(ON)}$
- Moisture Sensitivity Level 1
- Epoxy Meets UL 94 V-0 Flammability Rating
- Halogen Free

Applications

- Power switching application
- Uninterruptible power supply
- DC-DC convertor
- Motor drivers

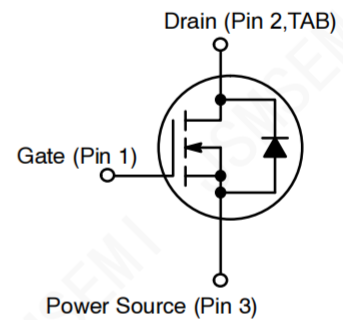
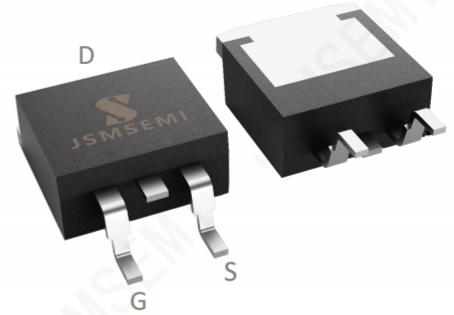

ABSOLUTE MAXIMUM RATINGS ($T_J=25^\circ\text{C}$ unless otherwise noted)

Parameter	Symbol	Value	Unit
Drain-Source Voltage	V_{DS}	100	V
Gate-Source Voltage	V_{GS}	± 20	V
Continuous Drain Current ($T_C=25^\circ\text{C}$) ⁽¹⁾	I_D	140	A
Continuous Drain Current ($T_C=100^\circ\text{C}$)	I_D	105	A
Pulsed Drain Current ⁽¹⁾	I_{DM}	560	A
Drain Power Dissipation	P_D	180	W
Single Pulsed Avalanche Energy ⁽²⁾	E_{AS}	340	mJ
Thermal Resistance from Junction to Ambient ⁽³⁾	$R_{\theta JA}$	43	$^\circ\text{C}/\text{W}$
Thermal Resistance from Junction to Case	$R_{\theta JC}$	1.0	$^\circ\text{C}/\text{W}$
Junction Temperature	T_J	-55~ +150	$^\circ\text{C}$
Storage Temperature	T_{STG}	-55~ +150	$^\circ\text{C}$

Notes:

- 1) Repetitive Rating: pulse width limited by maximum junction temperature
- 2) EAS condition : $T_J=25^\circ\text{C}$, $V_{DD}=50\text{V}$, $V_G=10\text{V}$, $L=1.0\text{mH}$, $R_g=25\Omega$, $I_{AS}=44.7\text{A}$
- 3) The value of $R_{\theta JA}$ Mounted on FR4 Board (25.4mm*25.4mm*t1.6mm) With 2oz Copper $T_A=25^\circ\text{C}$

MOSFET ELECTRICAL CHARACTERISTICS(T_J=25°C unless otherwise noted)

Parameter	Symbol	Test Condition	Min	Type	Max	Unit
Static Characteristics						
Drain-source breakdown voltage	V _{(BR)DSS}	V _{GS} = 0V, I _D = 250μA	100	-	-	V
Zero gate voltage drain current	I _{DSS}	V _{DS} = 100V, V _{GS} = 0V	-	-	1	μA
Gate-body leakage current	I _{GSS}	V _{GS} = ±20V, V _{DS} = 0V	-	-	±100	nA
Gate threshold voltage	V _{GS(th)}	V _{DS} = V _{GS} , I _D = 250μA	2.0	3.0	4.0	V
Drain-source on-resistance	R _{DS(on)}	V _{GS} = 10V, I _D = 20A	-	3.6	4.2	mΩ
Forward transconductance	R _g	V _{GS} = 0V, V _{DS} = 0V, f = 1.0MHz	-	2.0	-	Ω
Dynamic characteristics						
Input Capacitance	C _{iss}	V _{DS} = 50V, V _{GS} = 0V, f = 1MHz	-	4628	-	pF
Output Capacitance	C _{oss}		-	1624	-	
Reverse Transfer Capacitance	C _{rss}		-	19	-	
Switching characteristics						
Turn-on delay time	t _{d(on)}	V _{DD} = 50V, I _D = 20A, R _G = 3Ω, V _{GS} = 10V	-	12	-	nS
Turn-on rise time	t _r		-	26	-	
Turn-off delay time	t _{d(off)}		-	38	-	
Turn-off fall time	t _f		-	31	-	
Total Gate Charge	Q _g	V _{DS} = 50V, I _D = 20A, V _{GS} = 10V	-	61	-	nC
Gate-Source Charge	Q _{gs}		-	19.5	-	
Gate-Drain Charge	Q _{gd}		-	8.7	-	
Source-Drain Diode characteristics						
Diode Forward voltage	V _{SD}	T _J = 25°C, V _{GS} = 0V, I _S = 20A	-	0.8	1.2	V
Diode Forward current	I _S	T _C = 25°C	-	-	140	A
Body Diode Reverse Recovery Time	t _{rr}	T _J = 25°C, I _F = 20A, di/dt = 100A/us	-	77	-	nS
Body Diode Reverse Recovery Charge	Q _{rr}		-	189	-	nC

Ordering Information

Order number	Package	Marking	Operation Temperature Range	MSL Grade	Ship, Quantity	Green
IPB042N10N3GATMA1-JSM	TO-263	035N10BGH	-55 to 150°C	1	T&R, 800	Rohs

■ RATING AND CHARACTERISTIC CURVES

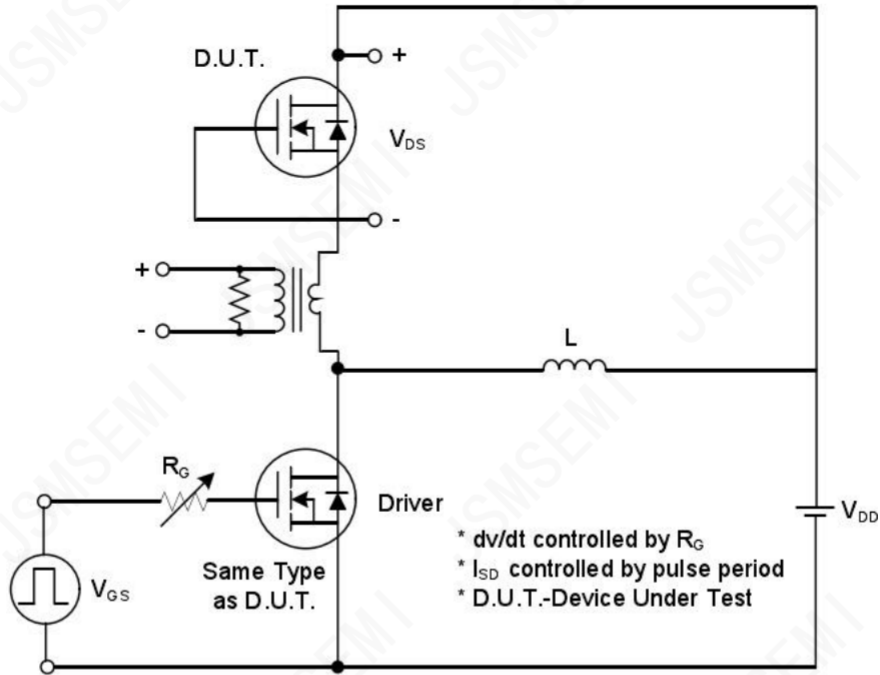

Peak Diode Recovery dv/dt Test Circuit

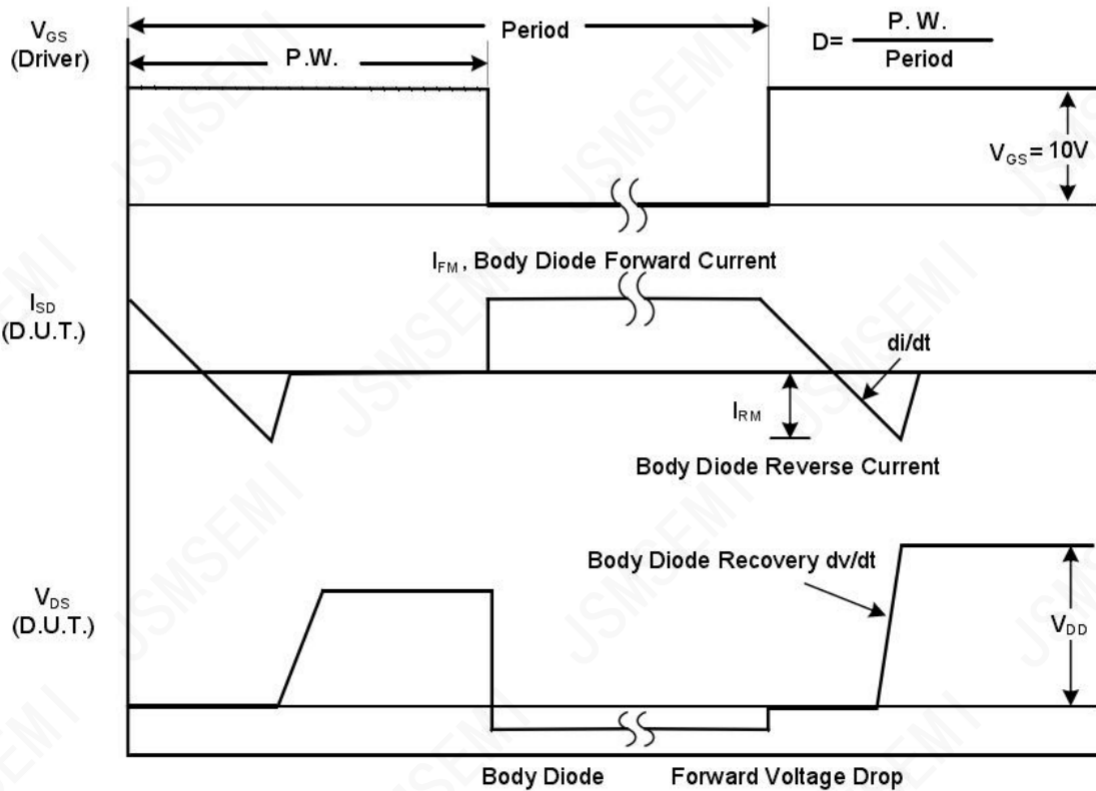

Peak Diode Recovery dv/dt Waveforms

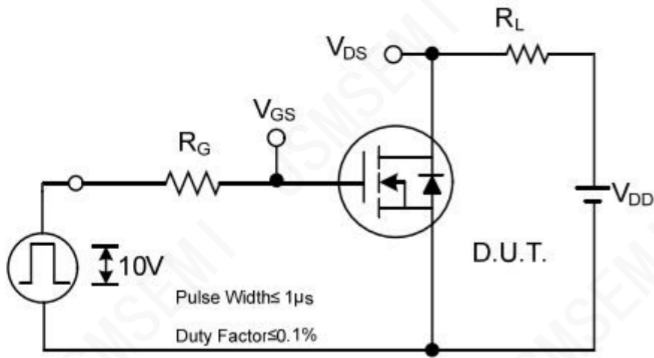

Switching Test Circuit

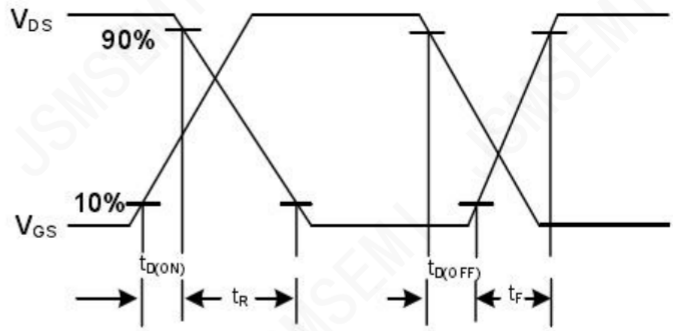

Switching Waveforms

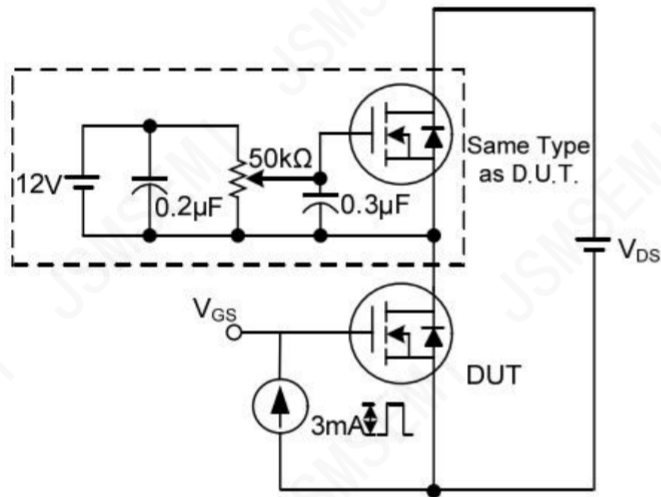

Gate Charge Test Circuit

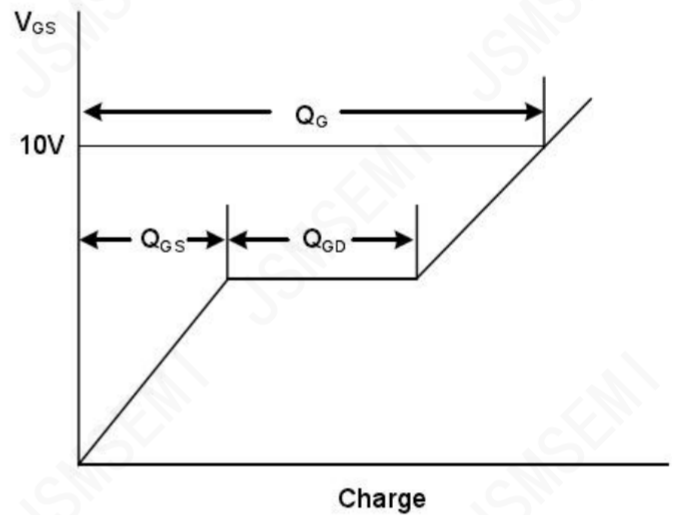

Gate Charge Waveform

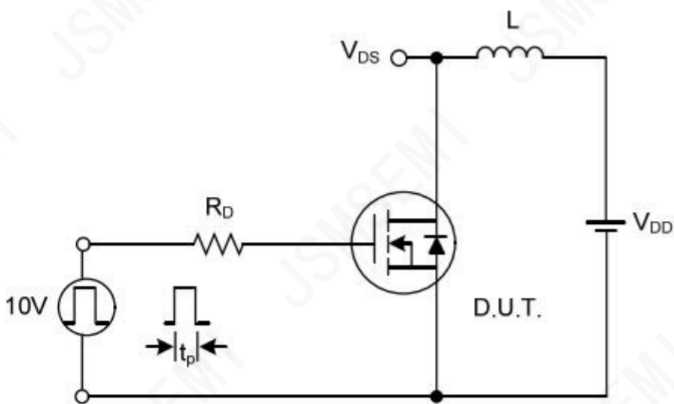

Unclamped Inductive Switching Test Circuit

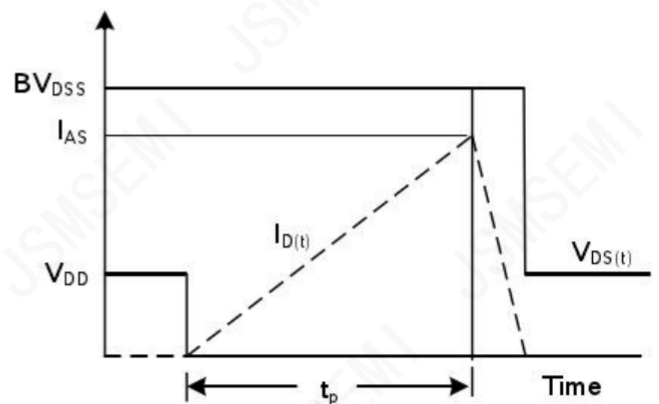

Unclamped Inductive Switching Waveforms

Typical Characteristics

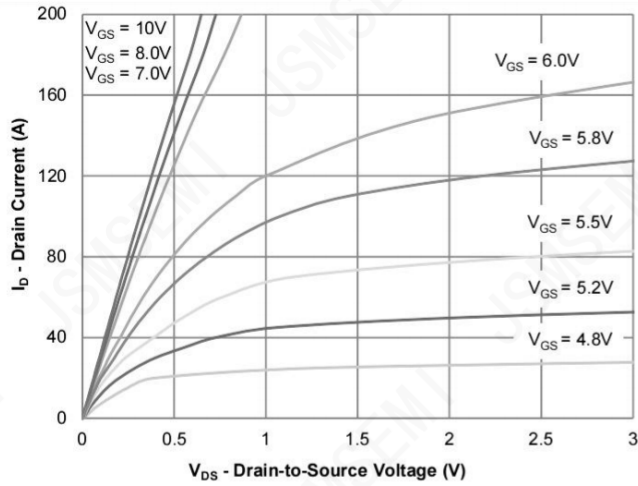

Figure 1: Output Characteristics

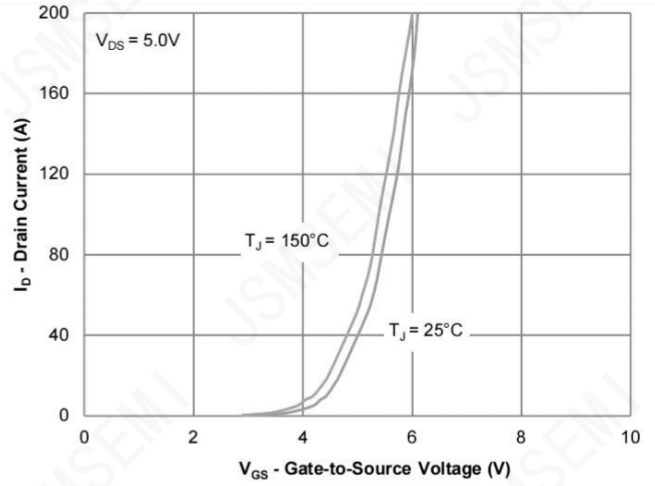

Figure 2: Transfer Characteristics

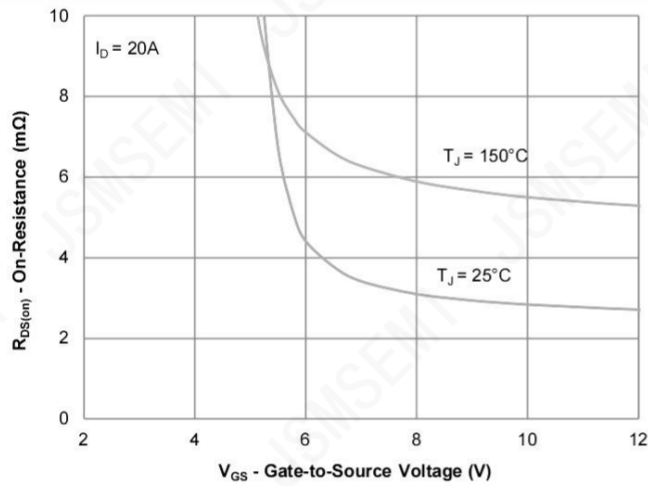

Figure 3: On-Resistance vs. Gate-Source Voltage

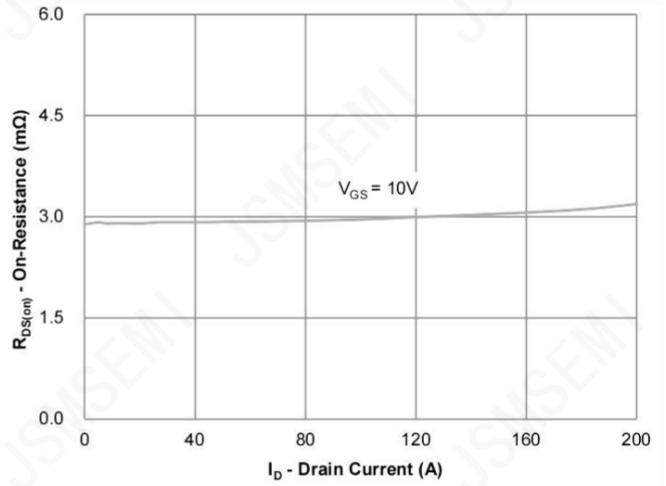

Figure 4: On-Resistance vs. Drain Current

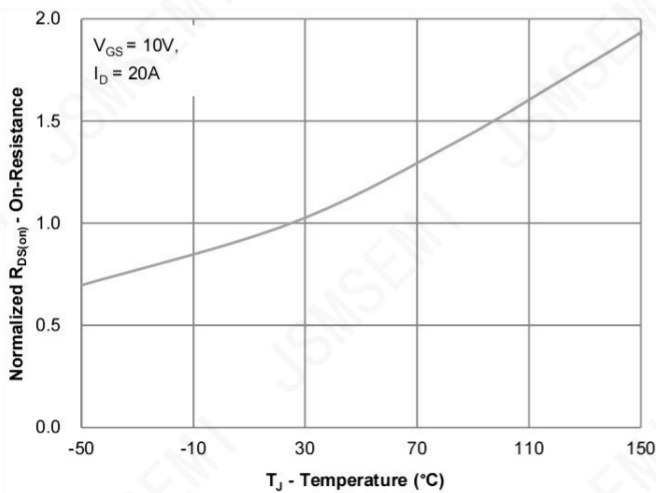

Figure 5: On-Resistance vs. Junction Temperature

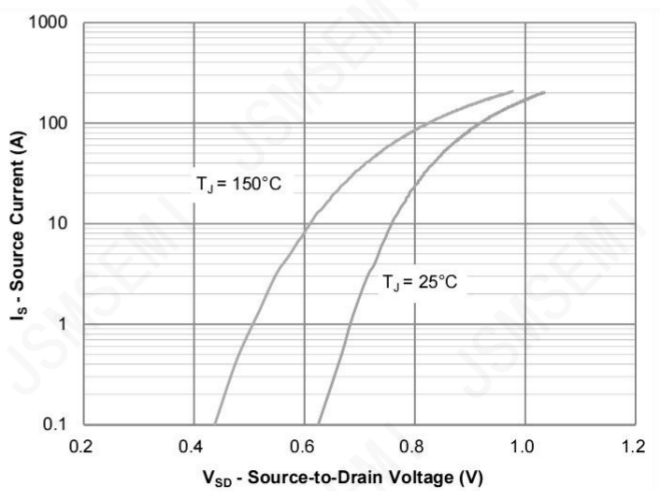

Figure 6: Source-Drain Diode Forward Voltage

Typical Characteristics

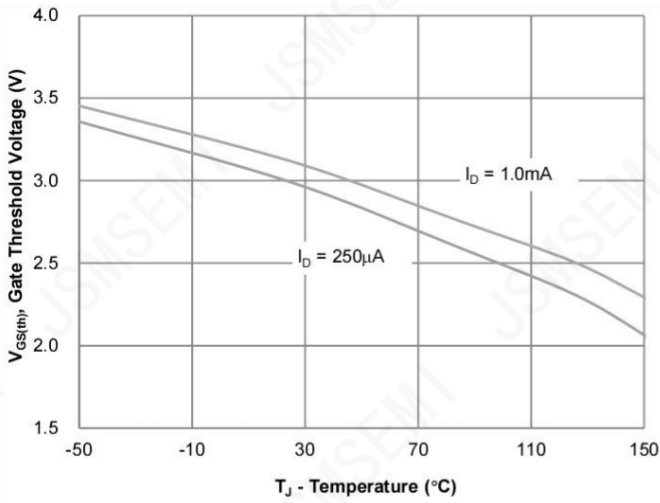

Figure 7: Gate Threshold Variation vs. Junction Temperature

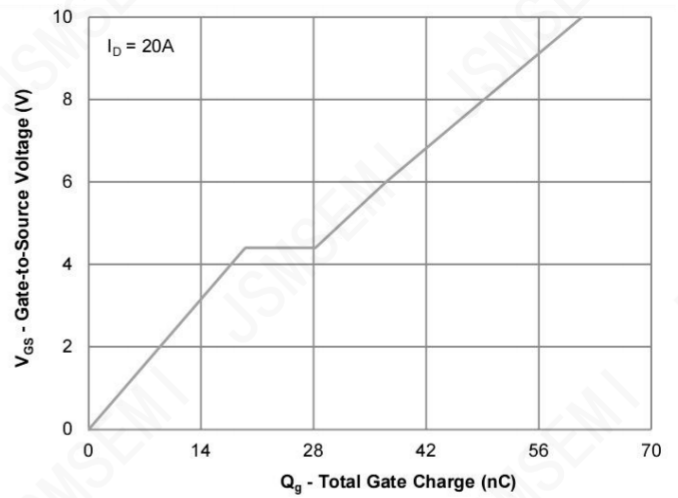

Figure 8: Gate Charge Characteristics

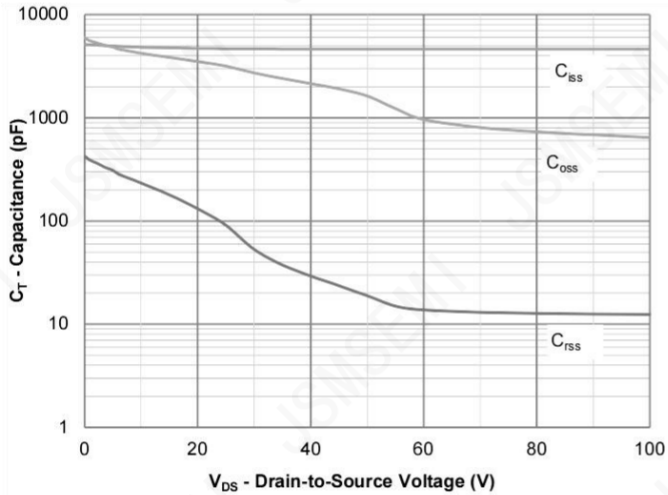

Figure 9: Capacitance Characteristics

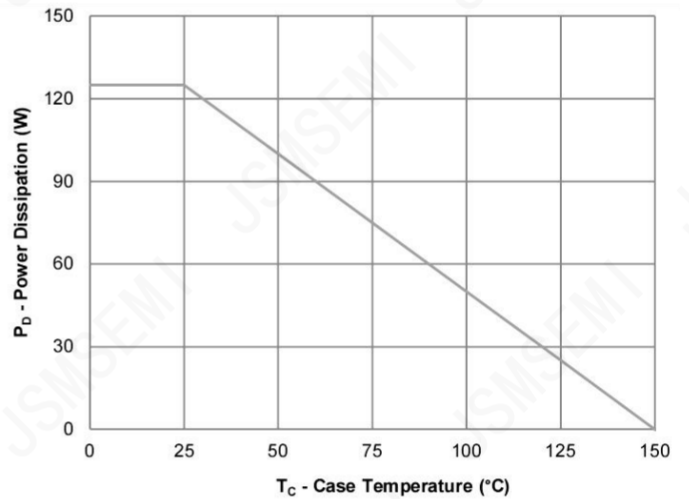

Figure 10: Power Derating

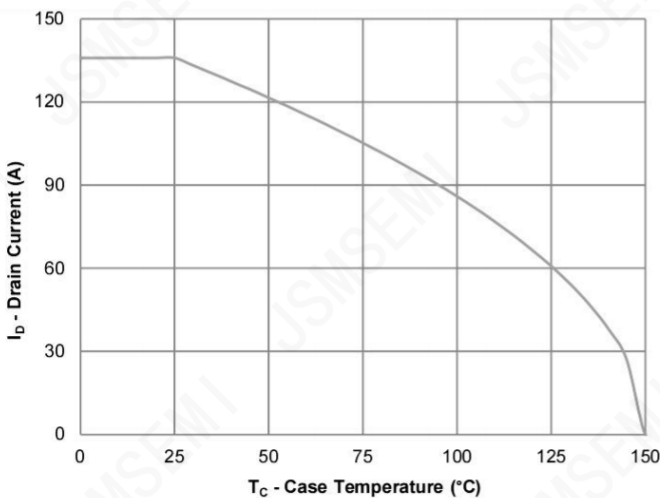

Figure 11: Current Derating

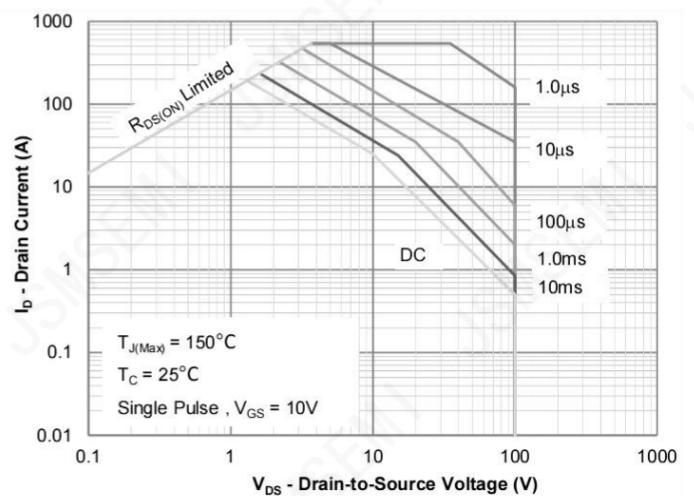

Figure 12: Safe Operating Area

Typical Characteristics

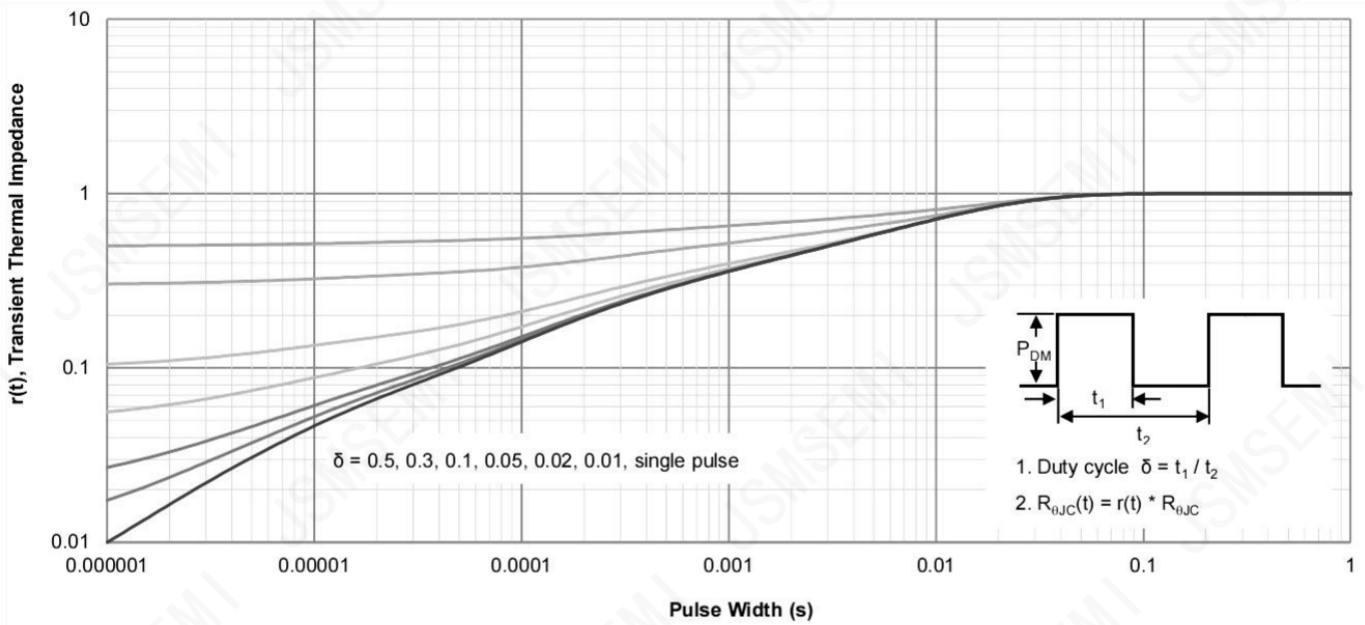
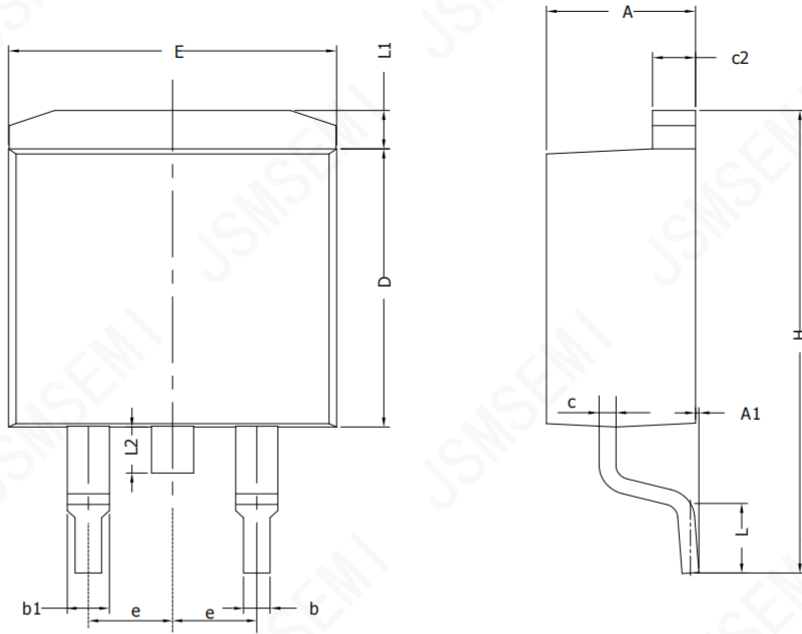

Figure 13: Normalized Maximum Transient Thermal Impedance

Package Information

TO-263-2



SYMBOL	MIN	NOM	MAX
A	4.30	4.57	4.72
A1	0	0.10	0.25
b	0.71	0.81	0.91
c	0.30	---	0.60
c2	1.17	1.27	1.37
D	8.50	---	9.35
E	9.80	---	10.45
e	2.54BSC		
H	14.70	---	15.75
L	2.00	2.30	2.74
L1	1.12	1.27	1.42
L2	---	---	1.75

Revision History

Rev.	Change	Date
V1.0	Initial version	9/17/2020

Important Notice

JSMSEMI Semiconductor (JSMSEMI) PRODUCTS ARE NEITHER DESIGNED NOR INTENDED FOR USE IN MILITARY AND/OR AEROSPACE, AUTOMOTIVE OR MEDICAL DEVICES OR SYSTEMS UNLESS THE SPECIFIC JSMSEMI PRODUCTS ARE SPECIFICALLY DESIGNATED BY JSMSEMI FOR SUCH USE. BUYERS ACKNOWLEDGE AND AGREE THAT ANY SUCH USE OF JSMSEMI PRODUCTS WHICH JSMSEMI HAS NOT DESIGNATED FOR USE IN MILITARY AND/OR AEROSPACE, AUTOMOTIVE OR MEDICAL DEVICES OR SYSTEMS IS SOLELY AT THE BUYER' S RISK.

JSMSEMI assumes no liability for application assistance or customer product design. Customers are responsible for their products and applications using JSMSEMI products.

Resale of JSMSEMI products or services with statements diferent from or beyond the parameters stated by JSMSEMI for that product or service voids all express and any implied warranties for the associated JSMSEMI product or s ervice. JSMSEMI is not responsible or liable for any such statements.

JSMSEMI All Rights Reserved. Information and data in this document are owned by JSMSEMI wholly and may not be edited, reproduced, or redistributed in any way without the express written consent from JSMSEMI.

Any and all information described or contained herein are subject to change without notice due to product/technology improvement, etc. When designing equipment, refer to the "Delivery Specification" for the JSMSEMI product that you intend to use.

For additional information please contact Kevin@jsmsemi.com or visit www.jsmsemi.com