

**0.8A 4Quadrants TRIACs**

**Product Summary**

Symbol	Value	Unit
$I_{T(RMS)}$	0.8	A
$V_{DRM} V_{RRM}$	800	V
$V_{TM}$	1.9	V

**General Description**

Glass passivated triacs in a plastic envelope suitable for surface mounting, intended for use in applications requiring high bidirectional transient and blocking voltage capability and high thermal cycling performance. Typical applications include motor control, industrial and domestic lighting, heating and static switching.

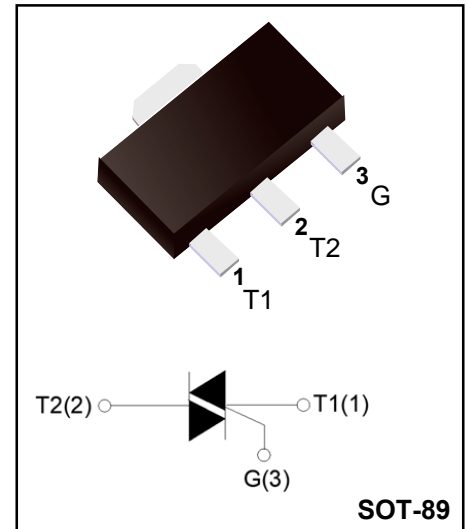

Marking Code	
MAC97A8SI	97A8

**Absolute Maximum Ratings (T<sub>j</sub>=25°C)**

Limiting values in accordance with the Absolute Maximum System

Parameter	Symbol	Value	Unit
Repetitive peak off-state voltage	$V_{DRM}$	800	V
Repetitive peak reverse voltage	$V_{RRM}$	800	V
RMS on-state current	$I_{T(RMS)}$	0.8	A
Non repetitive surge peak on-state current (full cycle, F=50Hz)	$I_{TSM}$	8	A
$I^2t$ value for fusing (tp=10ms)	$I^2t$	0.26	A <sup>2</sup> s
Critical rate of rise of on-state current ( $I_{TM} = 1.5A$ ; $I_G = 0.2A$ ; $dI_G/dt = 0.2 A/us$ )	$dI/dt$	T2+ G+	50
		T2+ G-	50
		T2- G-	50
		T2- G+	10
Peak gate current	$I_{GM}$	2	A
Average gate power dissipation	$P_{G(AV)}$	0.5	W
Junction Temperature	$T_J$	125	°C
Storage Temperature	$T_{STG}$	-40 ~ +150	°C

**Electrical Characteristics(T<sub>A</sub>=25°C)**

Parameter	Symbol	Test Condition	Value			Unit	
			Min	Typ	Max		
Gate trigger current	I <sub>GT</sub>	V <sub>D</sub> = 12V I <sub>T</sub> = 0.1A T <sub>j</sub> = 25°C	T2+ G+			5	mA
			T2+ G-			5	
			T2- G-			5	
			T2- G+			10	
Gate trigger voltage	V <sub>GT</sub>	V <sub>D</sub> = 12 V; I <sub>T</sub> = 0.1A			2.0	V	
		V <sub>D</sub> = V <sub>DRM</sub> ; I <sub>T</sub> = 0.1A; T <sub>j</sub> = 110°C	0.1			V	
Gate non-trigger voltage	V <sub>GD</sub>	V <sub>D</sub> = V <sub>DRM</sub> T <sub>j</sub> = 125°C			0.2	V	
latching current	I <sub>L</sub>	V <sub>D</sub> = 12V I <sub>GT</sub> = 0.1A	T2+ G+			10	mA
			T2+ G-			10	
			T2- G-			10	
			T2- G+			15	
Holding current	I <sub>H</sub>	V <sub>D</sub> = 12V, I <sub>GT</sub> = 0.1A			10	mA	
Critical-rate of rise of commutation voltage	dV/dt	V <sub>DM</sub> = 67% V <sub>DRM</sub> (max); T <sub>C</sub> = 110°C	30			V/μs	

**STATIC CHARACTERISTICS**

On-state Voltage	V <sub>TM</sub>	I <sub>T</sub> = 1.2A			1.9	V
Repetitive Peak Off-State Current	I <sub>DRM</sub>	V <sub>D</sub> = V <sub>DRM</sub> V <sub>R</sub> = V <sub>RDM</sub>	T <sub>j</sub> = 25°C		20	μA
Repetitive Peak Reverse Current	I <sub>RRM</sub>		T <sub>j</sub> = 125°C		100	μA

**THERMAL RESISTANCES**

Thermal resistance	R <sub>th(j-c)</sub>	Junction to case(AC)	TYP.	75	°C/W
	R <sub>th(j-a)</sub>	Junction to ambient	TYP.	200	°C/W

**Ordering Information**

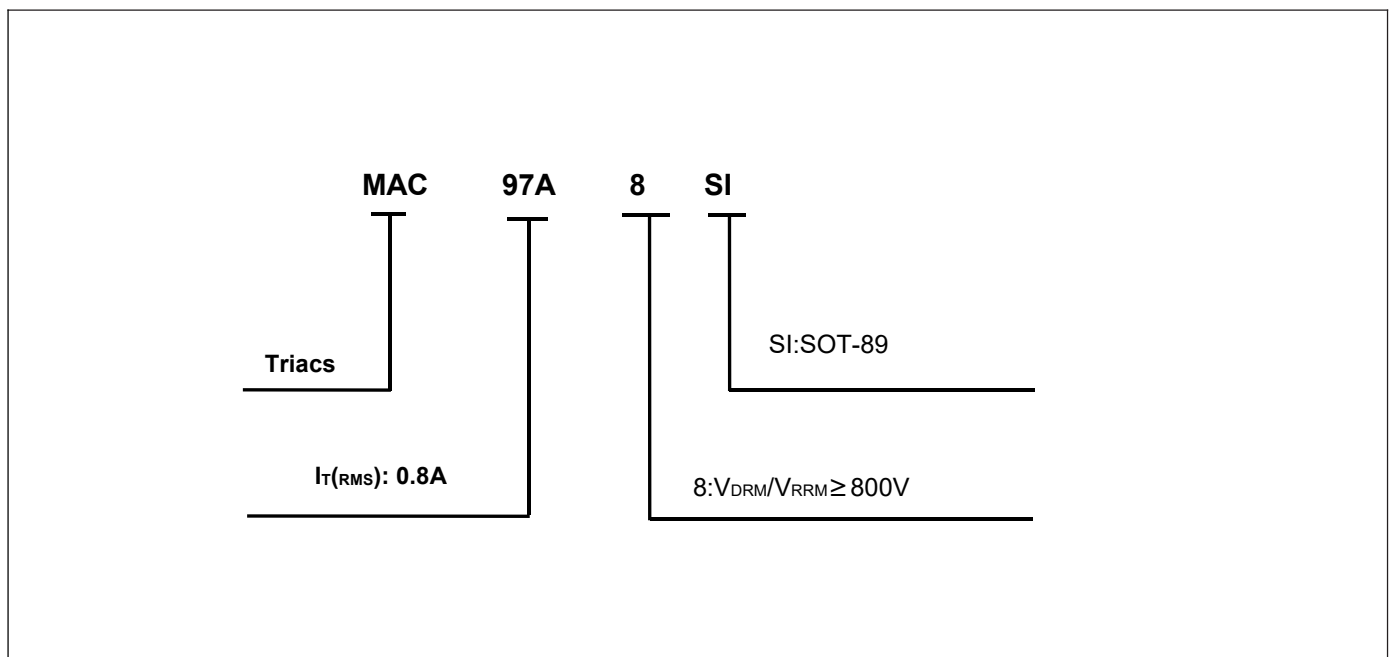

Typical Characteristic Curves

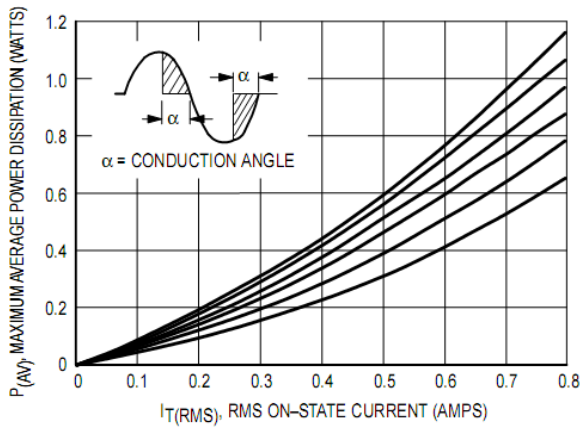

Figure 1. RMS Current Derating

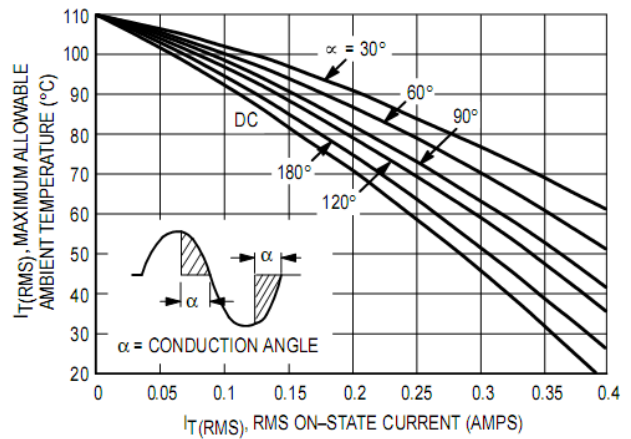

Figure 2. RMS Current Derating

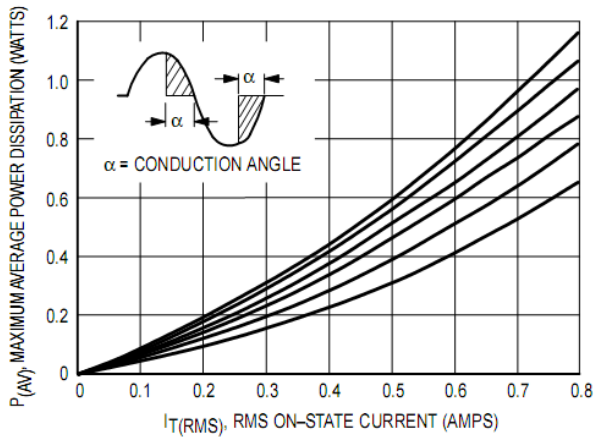

Figure 3. Power Dissipation

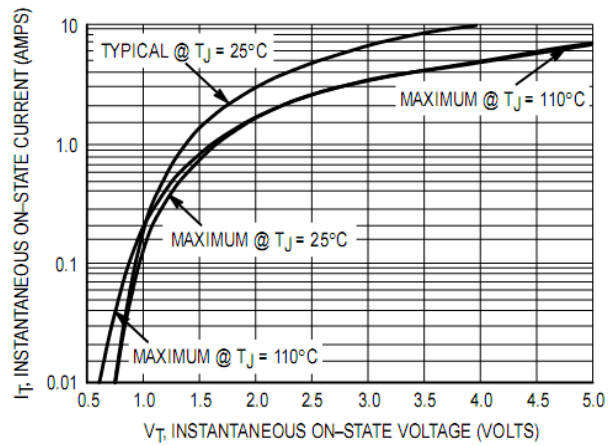

Figure 4. On-State Characteristics

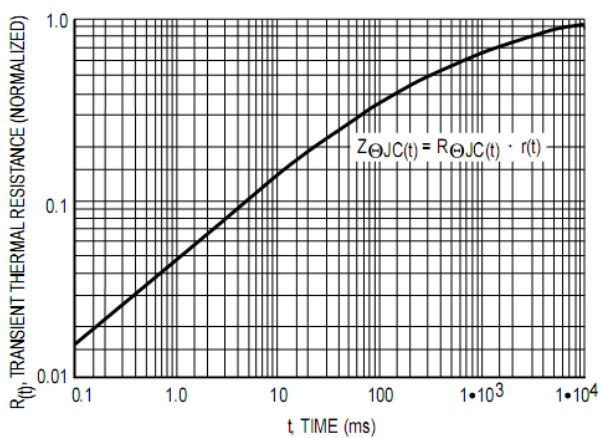

Figure 5. Transient Thermal Response

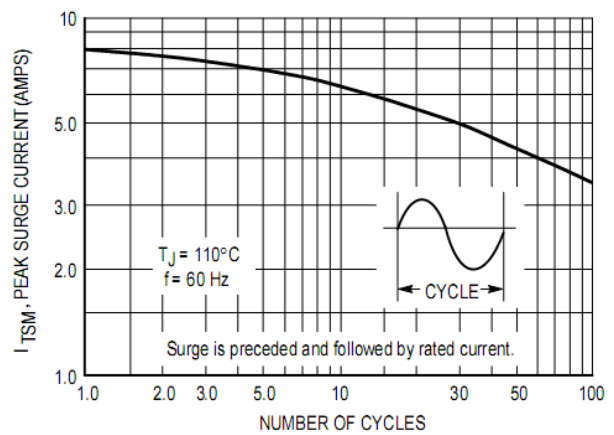
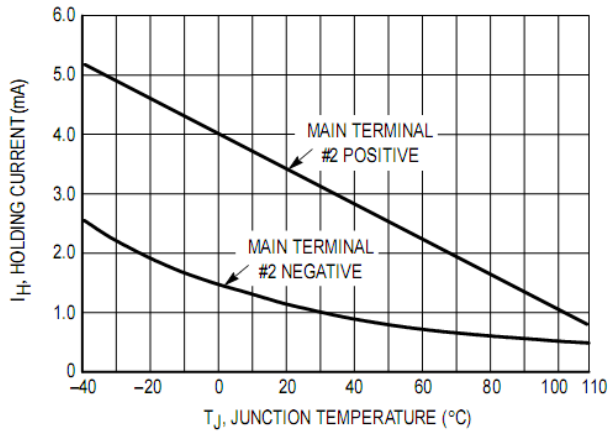
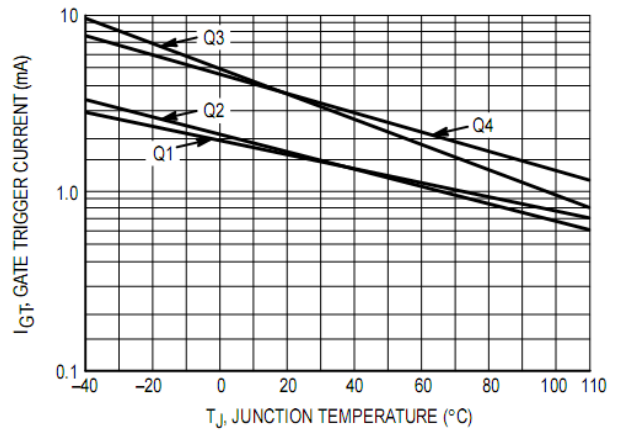

Figure 6. Maximum Allowable Surge Current



**Figure 7. Typical Holding Current Variation**



**Figure 8. Typical Gate Trigger Current**

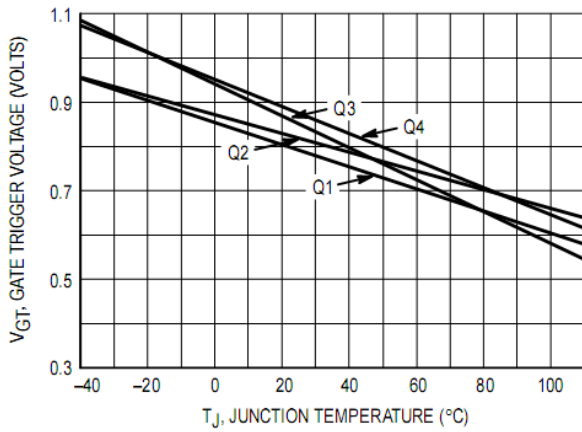

**Figure 9. Gate Trigger Voltage Variation**

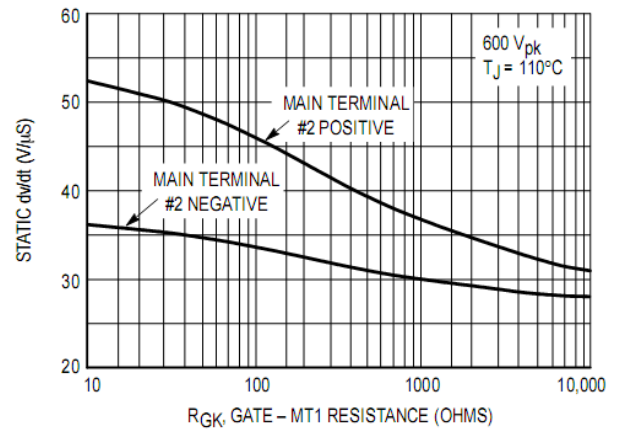

**Figure 10. Exponential Static dv/dt versus Gate-T1 Resistance**

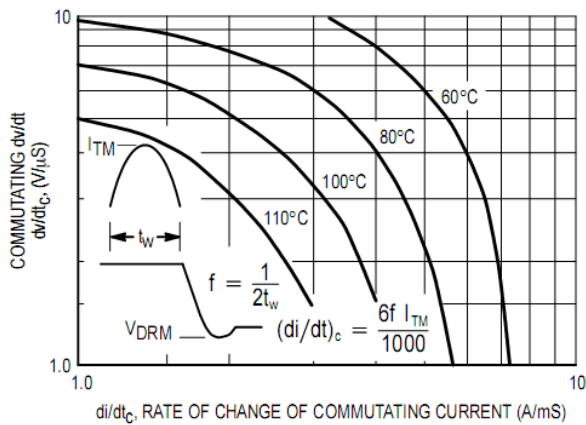

**Figure 11. Typical Commutating dv/dt versus Current Crossing Rate and Junction Temperature**

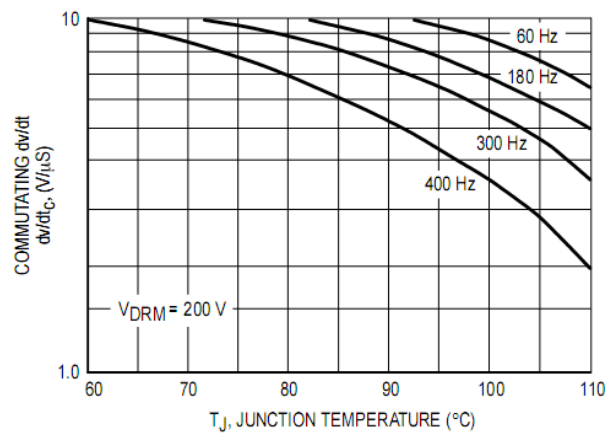

**Figure 12. Typical Commutating dv/dt versus Junction Temperature at 0.8 Amps RMS**

**Ordering information**

Package	Packing Description	Base Quantity	Packing Quantity
SOT-89	Tape/Reel,7"reel	1000pcs/Reel	6000PCS/Box 30000PCS/Carton

**Package Dimensions**

**SOT-89**

Dim	Millimeter		Inches	
	Min.	Max.	Min.	Max.
A	1.40	1.60	0.055	0.063
b	0.32	0.52	0.013	0.020
b1	0.38	0.58	0.015	0.023
c	0.35	0.45	0.014	0.018
D	4.40	4.60	0.173	0.181
D1	1.45	1.65	0.057	0.065
D2	1.70	1.80	0.067	0.071
E	2.30	2.60	0.091	0.102
E1	3.95	4.25	0.156	0.167
E2	1.80	2.00	0.071	0.079
e	1.40	1.60	0.055	0.063
e1	2.80	3.20	0.110	0.126
L	0.90	1.20	0.035	0.047

**The recommended mounting pad size**

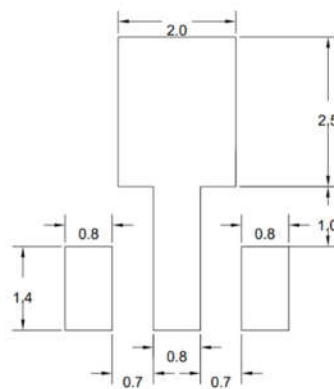

UNIT:MM

## Disclaimer

The information presented in this document is for reference only. Guangdong Youfeng Microelectronics Co.,Ltd. reserves the right to make changes without notice for the specification of the products displayed herein to improve reliability, function or design or otherwise. The product listed herein is designed to be used with ordinary electronic equipment or devices, and not designed to be used with equipment or devices which require high level of reliability and the malfunction of which would directly endanger human life (such as medical instruments, transportation equipment, aerospace machinery, nuclear-reactor controllers, fuel controllers and other safety devices), YFW or anyone on its behalf, assumes no responsibility or liability for any damages resulting from such improper use of sale. This publication supersedes & replaces all information previously supplied. For additional information, please visit our website <https://www.yfwdiode.com>, or consult YFW sales office for further assistance.