

Glass Passivated Junction Transient Voltage Suppressor

Voltage - 6.8 to 600 Volts

600 Watt Peak Power/5.0Watt Steady State

Features

- Plastic package
- Glass passivated chip junction in DO-15 Package
- 600W surge capability at 10/1000 μ s wave form
- Excellent clamping capability
- Low zener impedance
- Fast response time: typically less than 1.0ps from 0 Volts to B_V min.
- Typical IR less than 1 μ A above 10V
- High temperature soldering guaranteed: 265°C/10 seconds/.375", (9.5mm) lead length, 5lbs., (2.3kg) tension
- Pb-free plated



Mechanical Data

- **Case:** JEDEC DO-15 Molded plastic
- **Terminals:** Solderable per MIL-STD-750, Method 2026
- **Polarity:** Color band denotes cathode except Bipolar
- **Mounting Position:** Any

Devices For Bipolar Application

- For Bidirectional use C or CA Suffix for types P6KE6.8 thru types P6KE600 (e.g. P6KE6.8C, P6KE600CA)
- Electrical characteristics apply in both directions

Maximum Ratings And Characteristics

Ratings at 25°C ambient temperature unless otherwise specified.

RATING	SYMBOL	VALUE	UNITS
Peak Pulse Power Dissipation at $T_A = 25^\circ\text{C}$, $T_P = 1\text{ms}$ (Note 1)	P_{PPM}	600	Watts
Steady State Power Dissipation at $T_L = 75^\circ\text{C}$, Lead lengths. 375", (9.5mm) (Note 2)	$P_{M(AV)}$	5	Watts
Peak Forward Surge Current, 8.3ms Single Half Sine-Wave Superimposed on Rated Load, (JEDEC Method) (Note3)	I_{FSM}	100	Amps
Operating junction and Storage Temperature Range	T_J, T_{STG}	-55 to +175	°C

Notes :

1. Non-repetitive current pulse, per Fig. 3 and derated above $T_A = 25^\circ\text{C}$ per Fig. 2.
2. Mounted on Copper Pad area of 1.6×1.6" (40×40mm) per Fig. 5
3. 8.3ms single half sine-wave, or equivalent square wave, Duty cycle = 4 pulses per minutes maximum.

Dimensions (DO-15)

DO-204AC(DO-15)

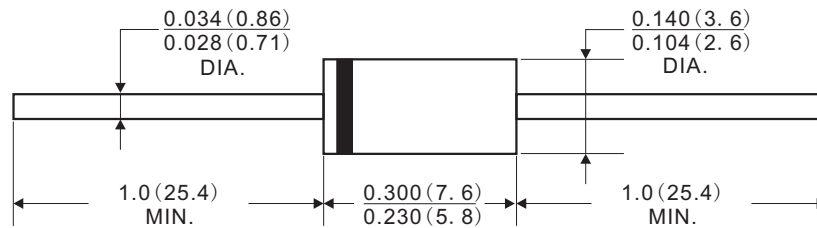

Dimensions in inches and(millimeters)

Electrical Characteristics

TABLE1

**Stand for commonly used models

P6KE Part Number		Reverse Stand-Off Voltage	Breakdown Voltage @IT	Breakdown Voltage @IT	Test Current	Maximum Clamping Voltage @Ipp	Peak Pulse Current	Reverse Leakage @VRWM
UNI-Polar	BI-Polar	VRWM(V)	VBR(V)Min.	VBR(V)Max.	IT(mA)	Vc(V)	Ipp(A)	IR(μA)
* P6KE6.8A	* P6KE6.8CA	5.80	6.45	7.14	10	10.5	58.1	600
P6KE7.5A	P6KE7.5CA	6.40	7.13	7.88	10	11.3	54.0	400
P6KE8.2A	* P6KE8.2CA	7.02	7.79	8.61	10	12.1	50.4	200
P6KE9.1A	P6KE9.1CA	7.78	8.65	9.55	1	13.4	45.5	50
P6KE10A	* P6KE10CA	8.55	9.50	10.50	1	14.5	42.1	10
P6KE11A	P6KE11CA	9.40	10.50	11.60	1	15.6	39.1	5
P6KE12A	* P6KE12CA	10.20	11.40	12.60	1	16.7	36.5	5
* P6KE13A	P6KE13CA	11.10	12.40	13.70	1	18.2	33.5	1
P6KE15A	* P6KE15CA	12.80	14.30	15.80	1	21.2	28.8	1
P6KE16A	P6KE16CA	13.60	15.20	16.80	1	22.5	27.1	1
P6KE18A	P6KE18CA	15.30	17.10	18.90	1	25.2	24.2	1
* P6KE20A	P6KE20CA	17.10	19.00	21.00	1	27.7	22.0	1
P6KE22A	* P6KE22CA	18.80	20.90	23.10	1	30.6	19.9	1
* P6KE24A	* P6KE24CA	20.50	22.80	25.20	1	33.2	18.4	1
P6KE27A	P6KE27CA	23.10	25.70	28.40	1	37.5	16.3	1
P6KE30A	* P6KE30CA	25.60	28.50	31.50	1	41.4	14.7	1
* P6KE33A	P6KE33CA	28.20	31.40	34.70	1	45.7	13.3	1
* P6KE36A	P6KE36CA	30.80	34.20	37.80	1	49.9	12.2	1
P6KE39A	* P6KE39CA	33.30	37.10	41.00	1	53.9	11.3	1
* P6KE43A	P6KE43CA	36.80	40.90	45.20	1	59.3	10.3	1
P6KE47A	P6KE47CA	40.20	44.70	49.40	1	64.8	9.4	1
* P6KE51A	P6KE51CA	43.60	48.50	53.60	1	70.1	8.7	1

Notes :

- 1.For bidirectional type having VRWM of 10 volts and less, the IR limit is double
- 2.For parts with A , the VBR is ± 5%

Electrical Characteristics

TABLE 1

***Stand for commonly used models

P6KE Part Number		Reverse Stand-Off Voltage	Breakdown Voltage @IT	Breakdown Voltage @IT	Test Current	Maximum Clamping Voltage @Ipp	Peak Pulse Current	Reverse Leakage @VRWM
UNI-Polar	BI-Polar	VRWM(V)	VBR(V)Min.	VBR(V)Max.	IT(mA)	Vc(V)	Ipp(A)	IR(μA)
P6KE56A	P6KE56CA	47.80	53.20	58.80	1	77.0	7.9	1
P6KE62A	P6KE62CA	53.00	58.90	65.10	1	85.0	7.2	1
P6KE68A	* P6KE68CA	58.10	64.60	71.40	1	92.0	6.6	1
P6KE75A	* P6KE75CA	64.10	71.30	78.80	1	103.0	5.9	1
P6KE82A	P6KE82CA	70.10	77.90	86.10	1	113.0	5.4	1
P6KE91A	P6KE91CA	77.80	86.50	95.50	1	125.0	4.9	1
P6KE100A	P6KE100CA	85.50	95.00	105.00	1	137.0	4.5	1
P6KE110A	P6KE110CA	94.00	105.00	116.00	1	152.0	4.0	1
P6KE120A	P6KE120CA	102.00	114.00	126.00	1	165.0	3.7	1
P6KE130A	P6KE130CA	111.00	124.00	137.00	1	179.0	3.4	1
P6KE150A	P6KE150CA	128.00	143.00	158.00	1	207.0	2.9	1
* P6KE160A	P6KE160CA	136.00	152.00	168.00	1	219.0	2.8	1
P6KE170A	P6KE170CA	145.00	162.00	179.00	1	234.0	2.6	1
* P6KE180A	P6KE180CA	154.00	171.00	189.00	1	246.0	2.5	1
* P6KE200A	P6KE200CA	171.00	190.00	210.00	1	274.0	2.2	1
P6KE220A	P6KE220CA	185.00	209.00	231.00	1	328.0	1.9	1
P6KE250A	P6KE250CA	214.00	237.00	263.00	1	344.0	1.8	1
P6KE300A	P6KE300CA	256.00	285.00	315.00	1	414.0	1.5	1
P6KE350A	P6KE350CA	300.00	332.00	368.00	1	482.0	1.3	1
* P6KE400A	*P6KE400CA	342.00	380.00	420.00	1	548.0	1.1	1
* P6KE440A	*P6KE440CA	376.00	418.00	462.00	1	602.0	1.0	1
P6KE480A	P6KE480CA	408.00	456.00	504.00	1	658.0	0.9	1
P6KE510A	P6KE510CA	434.00	485.00	535.00	1	698.0	0.9	1
P6KE530A	*P6KE530CA	450.00	503.50	556.50	1	725.0	0.8	1
P6KE540A	P6KE540CA	459.00	513.00	567.00	1	740.0	0.8	1
* P6KE550A	*P6KE550CA	467.00	522.50	577.50	1	760.0	0.8	1
P6KE600A	P6KE600CA	512.00	570.00	630.00	1	828.0	0.75	1

Notes :

- 1.For bidirectional type having VRWM of 10 volts and less, the IR limit is double
- 2.For parts with A , the VBR is ± 5%

Rating And Characteristic Curves

Fig.1 Peak Pulse Power Rating Curve

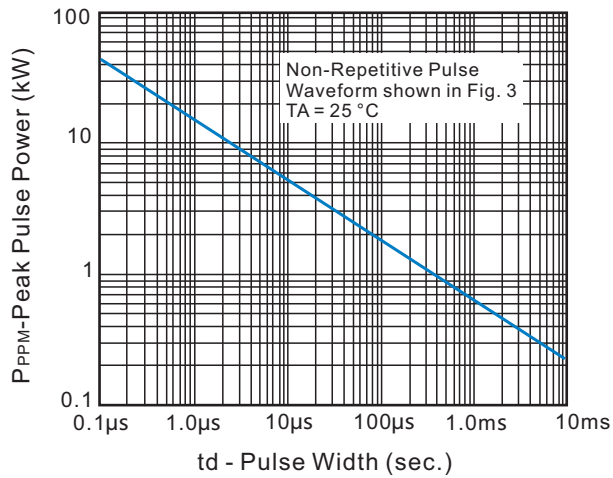

Fig.2 Pulse Derating Curve

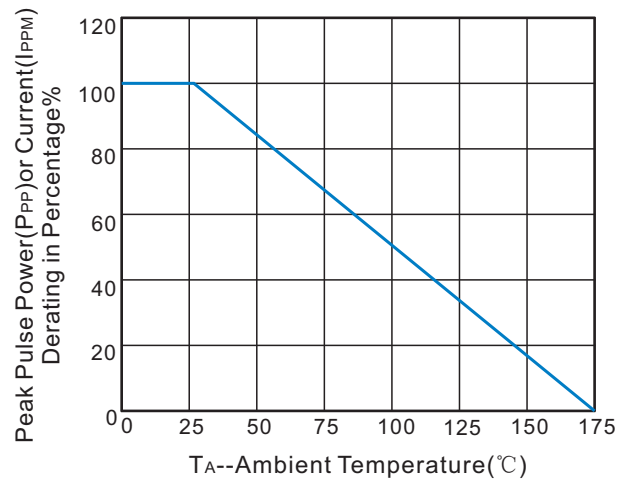

Fig.3 Pulse Waverform

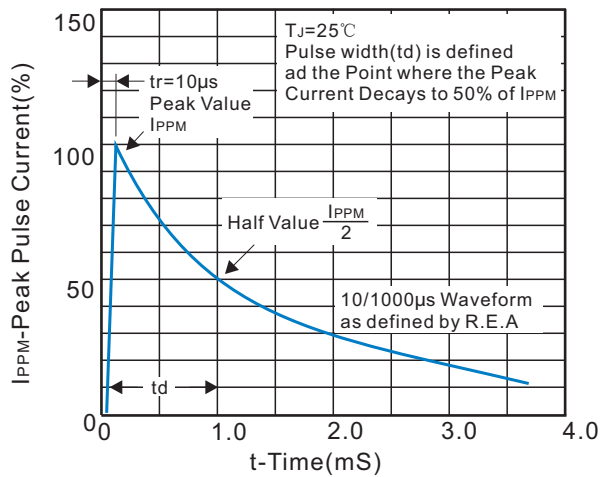

Fig.4 Typ. Junction Capacitance Uni-Directional

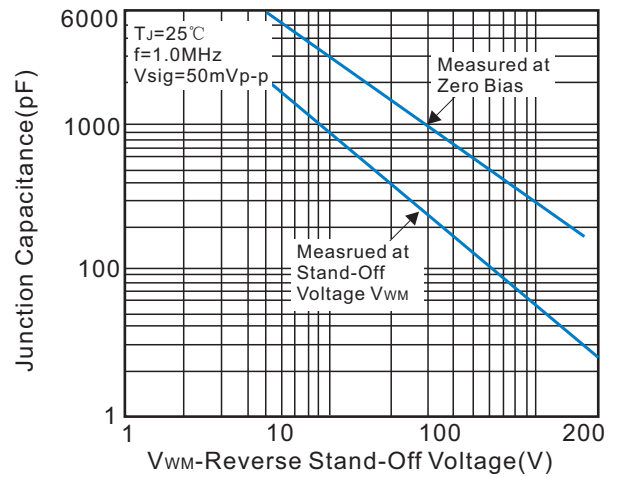

Fig.5 Steady State Power Dissipation Derating Curve

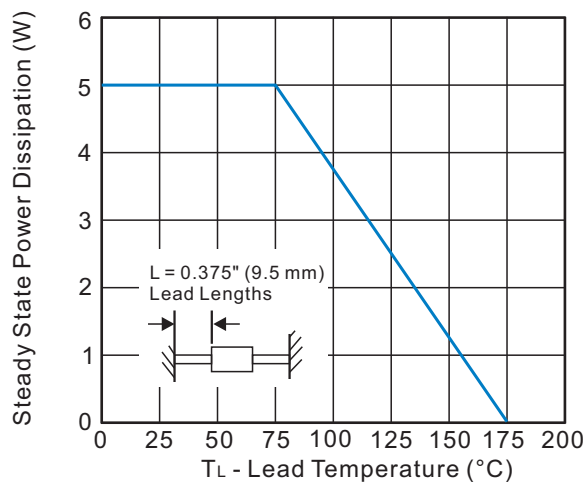
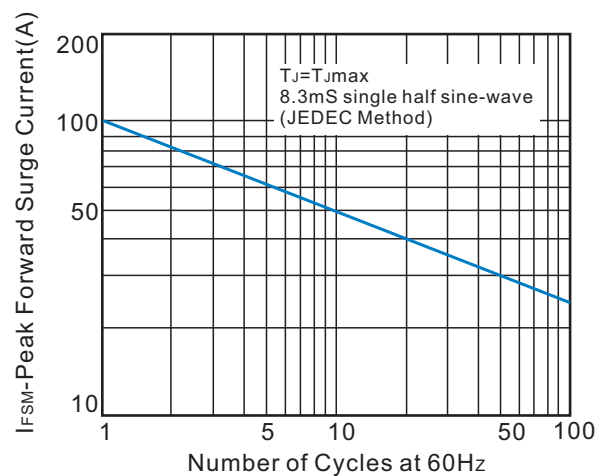

Fig.6 Maximum Non-Repetitive Peak Forward Surge Current Uni-Directional Only



Recommended Soldering Conditions

Recommended Conditions

Reflow Condition		Pb-Free assembly (see Fig.1)
Pre Heat	-Temperature Min($T_{s(min)}$)	+150°C
	-Temperature Max($T_{s(max)}$)	+200°C
	-Time(Min to Max)(t_s)	60-180secs
Average ramp up rate (Liquidus Temp(T_L) to peak)		3°C/sec.Max.
$T_{s(max)}$ to T_L -Ramp-up Rate		3°C/sec.Max.
Reflow	-Temperature(T_L)(Liquidus)	+217°C
	-Temperature(t_L)	60-150secs
Peak Temp(T_P)		+260(+0/-5)°C
Time within 5°C of actual Peak Temp(t_P)		30 secs.Max.
Ramp-down Rate		6°C/sec.Max.
Time 25°C to Peak Temp(T_P)		8 min.Max.
Do not exceed		+260°C

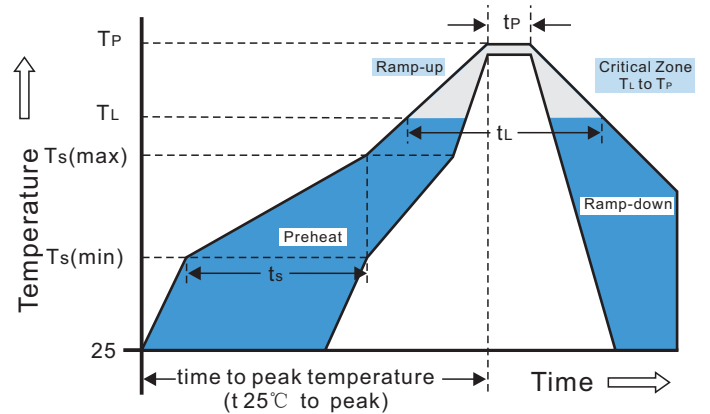

Reflow/Wave Soldering(Solder Dipping)

Peak Temperature	260°C
Dipping Time	10seconds
Soldering	1time

Marking Code

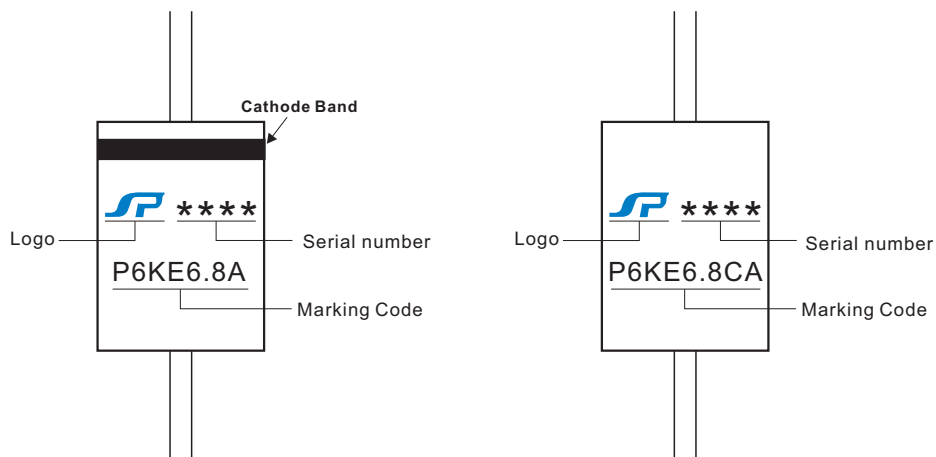

Packaging

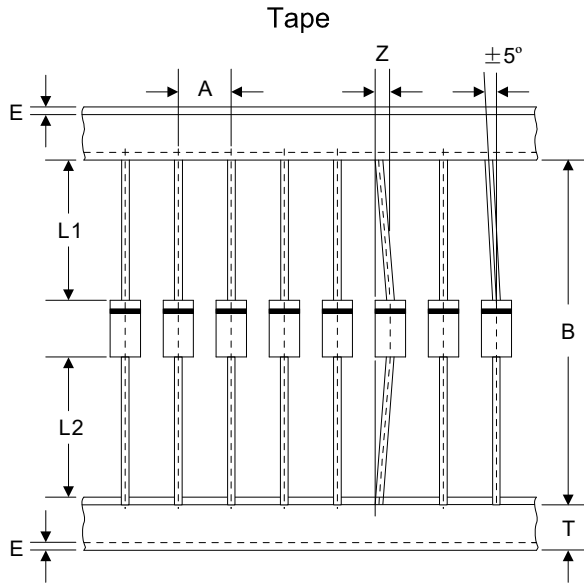

Box

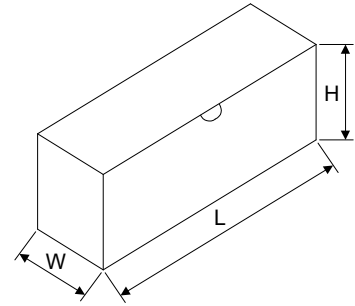

Dimensions in millimeters

A	B	Z	T	E	L1-L2
5.0 ± 0.5	52.0 ± 1.0	1.2Max	6.0 ± 0.4	3.0Max	1.0Max

L	W	H	Quantity
250.0 ± 5.0	78.0 ± 5.0	114.0 ± 5.0	2000PCS