

HC120N120R4R

1200V N-Channel SiC MOSFET

产品特点/Product features

- Kelvin source configuration
开尔文源极配置
- Low specific on-resistance
低导通电阻
- Fast switching speed
快速切换速度
- Controllable dv/dt for optimized EMI
可控的(dv/dt), 用于实现EMI优化设置
- 0V turn-off V_{GS} for simple gate driving
0V关断栅源电压, 简化栅极驱动
- 100% UIS Tested
100% UIS测试
- Easy to parallel
易于并联

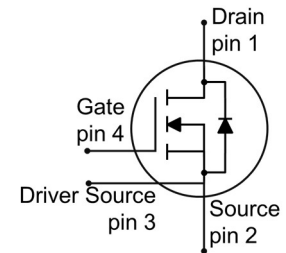
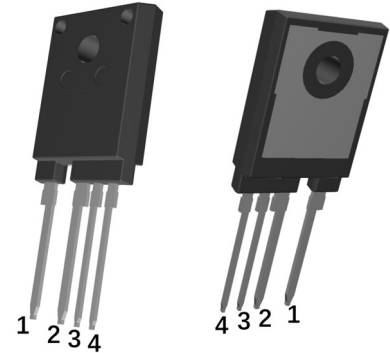

应用领域/Applications

- UPS (Uninterruptible Power Supplies)
不间断电源 (UPS)
- Switch Mode Power Supplies (SMPS)
开关模式电源
- Solar string inverter and solar optimizer
太阳能电池组逆变器、太阳能优化器
- EV Charger
电动汽车充电桩
- Motor Drives
电机驱动

关键性能参数/Key Performance Parameters

Parameter	Value	Unit
V_{DSS}	1200	V
$R_{DS(on),typ}$	120	m Ω
I_{DM}	58	A



Type/型号	Package/封装	Marking/标识	Packaging method/包装方式
HC120N120R4R	TO247-4L(HC)	HC120N120R	Tube/管装

1200V N-Channel SiC MOSFET HC120N120R4R



1. Maximum ratings at $T_j = 25^\circ\text{C}$, unless otherwise specified.

最大额定值 默认 $T_j = 25^\circ\text{C}$ 除非另有说明

Table 1 Maximum ratings/最大额定值

Parameter 参数	Symbol 符号	Test conditions 测试条件	Value 值	Unit 单位
Drain-source voltage 漏极-源极电压	V_{DSS}	$T_j \geq 25^\circ\text{C}$	1200	V
Drain current ¹ 连续漏极电流	I_D	$T_C = 25^\circ\text{C}, V_{GS} = 18\text{V}$	28.7	A
		$T_C = 100^\circ\text{C}, V_{GS} = 18\text{V}$	20.3	
Peak drain current ² 峰值漏极电流	I_{DM}	$T_C \leq 175^\circ\text{C}$	58	A
Continuous diode current ¹ 连续二极管电流	I_S	$T_C = 25^\circ\text{C}, V_{GS} = -4\text{V}$	24.5	A
Peak diode current ² 峰值二极管电流	I_{SM}	$T_C = 25^\circ\text{C}, V_{GS} = -4\text{V}$	58	A
Maximum gate source voltage 栅源最大电压	$V_{GS,MAX}$		-12~24	V
Recommend gate source voltage 推荐的栅源电压	$V_{GS,op}$		-4~18	V
Avalanche energy, single pulse 单脉冲雪崩能量	E_{AS}	$I_{AS} = 7\text{A}, V_{DD} = 100\text{V}, L = 1\text{mH}$	24.5	mJ
Power dissipation ¹ 总耗散功率	P_{tot}	$T_C = 25^\circ\text{C}$	234	W
		$T_C = 100^\circ\text{C}$	117	
Mounting torque 安装扭矩	M_d	M3 and M3.5 screw M3或者M3.5螺钉	0.6	Nm

1. Limited by $T_j(\text{max})$ /受限于最大结温

2. Pulse width t_p limited by $T_j(\text{max})$ /脉宽受限于最大结温



2. Thermal characteristics

热特性

Table 2 Thermal characteristics/热特性

Parameter 参数	Symbol 符号	Test conditions 测试条件	Value/值			Unit 单位
			Min.	Typ.	Max.	
Storage Temperature 存储温度	T_{stg}		-55		175	°C
Operating junction Temperature 工作结温	T_j		-55		175	°C
Thermal resistance, junction-case 结-壳热阻	$R_{th(j-c)}$			0.64		K/W
Thermal resistance, junction-ambient 结-环境热阻	$R_{th(j-a)}$			40		K/W
Soldering temperature 焊接温度	T_{sold}				260	°C



3. Electrical characteristics at $T_j = 25^\circ\text{C}$, unless otherwise specified.

电气特性 默认 $T_j = 25^\circ\text{C}$ 除非另有说明

Table 3 Static characteristics/静态特性

Parameter 参数	Symbol 符号	Test conditions 测试条件	Value/值			Unit 单位	
			Min.	Typ.	Max.		
Drain-source breakdown voltage 漏源击穿电压	$V_{(BR)DSS}$	$I_D = 100\mu\text{A}, V_{GS} = 0\text{V}$	1200			V	
Gate threshold voltage 门极开启阈值电压	$V_{GS(th)}$	$I_D = 2.5\text{mA}, V_{DS} = V_{GS}$	$T_j = 25^\circ\text{C}$	1.9	2.6	3.5	V
			$T_j = 175^\circ\text{C}$		1.9		
Drain-source on-state resistance 漏极-源极导通电阻	$R_{DS(on)}$	$I_D = 10\text{A}, V_{GS(on)} = 15\text{V}$	$T_j = 25^\circ\text{C}$		150		m Ω
			$T_j = 25^\circ\text{C}$		120	150	
					$T_j = 175^\circ\text{C}$		
Zero gate voltage drain current 集电极-发射极漏电流	I_{DSS}	$V_{DS} = 1200\text{V}, V_{GS} = 0\text{V}$	$T_j = 25^\circ\text{C}$		0.2	50	μA
			$T_j = 175^\circ\text{C}$		2		
Gate to source Leakage current 门极-源极漏电流	I_{GSS}	$V_{DS} = 0\text{V}, V_{GS} = 120\text{V}, T_j = 25^\circ\text{C}$			100	nA	
			$V_{DS} = 0\text{V}, V_{GS} = -12\text{V}, T_j = 25^\circ\text{C}$				100
Forward transconductance 正向跨导	g_{fs}	$I_D = 10\text{A}, V_{DS} = 20\text{V}$		5.1		S	
Integrated gate resistor 内部门极电阻	R_G	$f = 1\text{MHz}$		3		Ω	

1200V N-Channel SiC MOSFET HC120N120R4R



Table 4 Dynamic characteristics/动态特性

Parameter 参数	Symbol 符号	Test conditions 测试条件	Value/值			Unit 单位
			Min.	Typ.	Max.	
Total gate charge 总栅极电荷	$Q_{G(tot)}$	$V_{DD}=800V,$ $I_D=10A,$ $V_{GS}=-4/18V$		40		nC
Gate source charge 栅-源极电荷	Q_{GS}			14.5		
Gate-drain charge 栅-漏极电荷	Q_{GD}			9.8		
Input capacitance 输入电容	C_{iss}	$V_{DS}=1000V,$ $V_{GS}=0V,$ $f=1MHz$		741		pF
Output capacitance 输出电容	C_{oss}			36		
Reverse transfer capacitance 反向传输电容	C_{rss}			3.4		
Coss stored energy 输出电容存储能量	E_{oss}	Calculated based on C_{oss}		18		μJ
Turn-On Delay Time 开启延迟时间	$t_{d(on)}$	$V_{DD}=800V,$ $I_D=10A,$ $V_{GS}=-4/18V,$ $R_{G(ext)}=5.1\Omega,$ $L=330\mu H$		3		ns
Rise time 上升时间	t_r			17		
Turn-Off Delay Time 关闭延迟时间	$t_{d(off)}$			6		
Turn-Off Fall Time 下降时间	t_f			33		
Turn-on switch loss 单次开启损耗	E_{on}			101		
Turn-off switch loss 单次关闭损耗	E_{off}		42			

Table 5 Reverse diode characteristics/体二极管反向特性

Parameter 参数	Symbol 符号	Test conditions 测试条件	Value/值			Unit 单位
			Min.	Typ.	Max.	
Drain-source reverse voltage 体二极管正向压降	V_{SD}	$I_S=5A, V_{GS}=0V, T_j=25^\circ C$		3.4		V
		$I_S=5A, V_{GS}=-4V, T_j=25^\circ C$		4.8		
		$I_S=5A, V_{GS}=-4V, T_j=175^\circ C$		4.1		
MOSFET forward recovery time MOSFET正向恢复时间	t_{fr}	$V_{DS}=400V,$ $I_S=10A,$ $-dis/dt=500A/\mu s$		17		ns
MOSFET forward recovery charge MOSFET正向恢复电荷	Q_{fr}			26		nC
MOSFET peak forward recovery current MOSFET正向恢复峰值电流	I_{frm}			2.7		A



4. Electrical characteristics diagrams
电气特性图表

Power dissipation/耗散功率
 $P_{tot}=f(T_c)$; @ $R_{th(j-c).typ}$

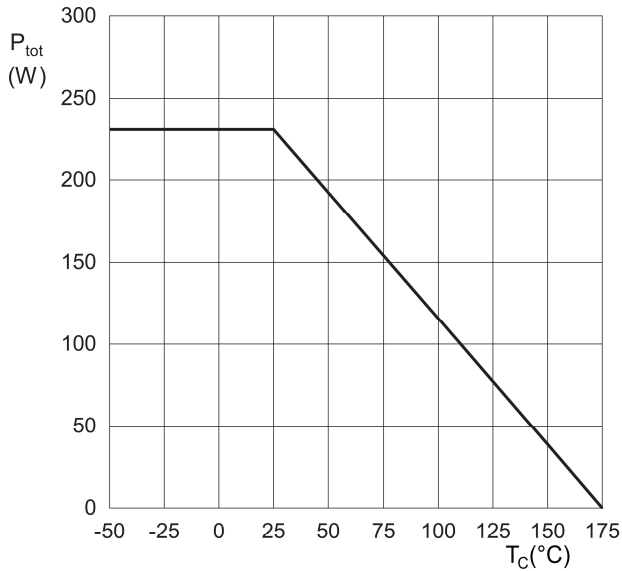

Continuous Drain Current/连续漏电流与壳温
 $I_{DS}=f(T_c)$; $V_{GS} \geq 18V$

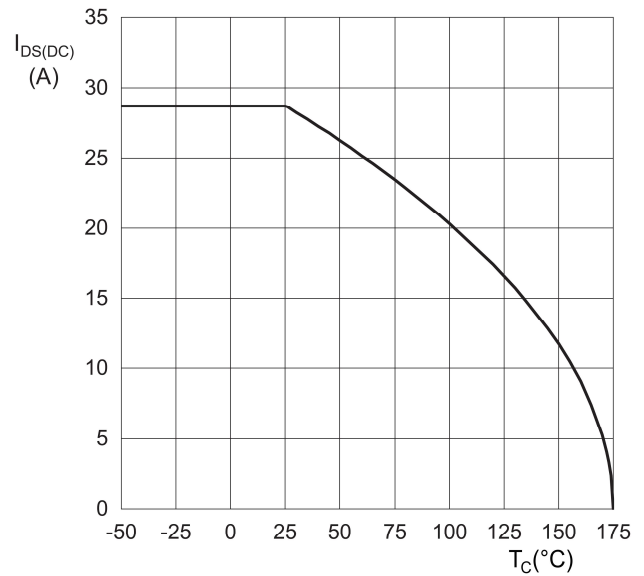

Typ. Output Characteristic/典型输出特性
 $I_{DS}=f(V_{DS})$; $T_c = -55^\circ C$

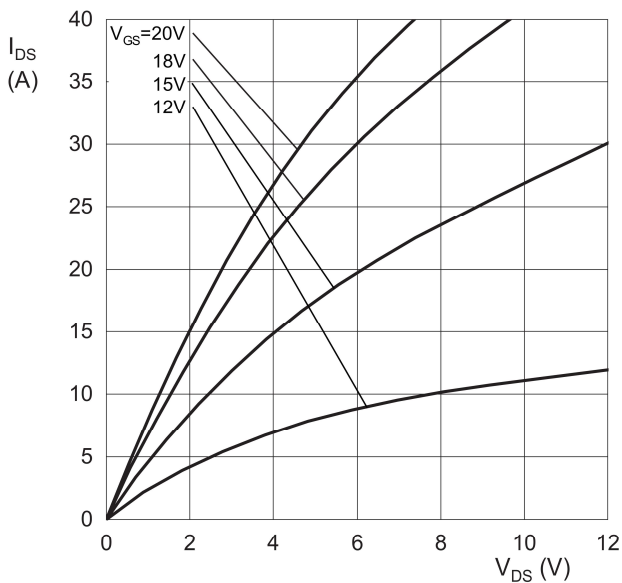

Typ. Output Characteristic/典型输出特性
 $I_{DS}=f(V_{DS})$; $T_c = 25^\circ C$

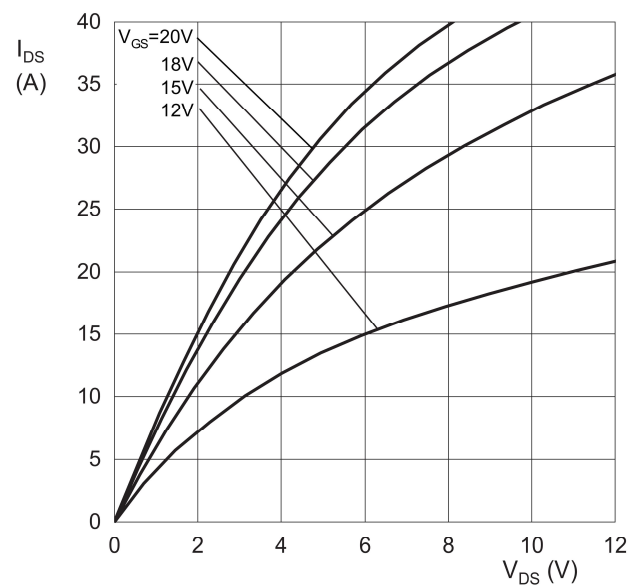

1200V N-Channel SiC MOSFET HC120N120R4R



Typ. Output characteristic/典型输出特性
 $I_{DS}=f(V_{DS}); T_C=175^\circ\text{C}$

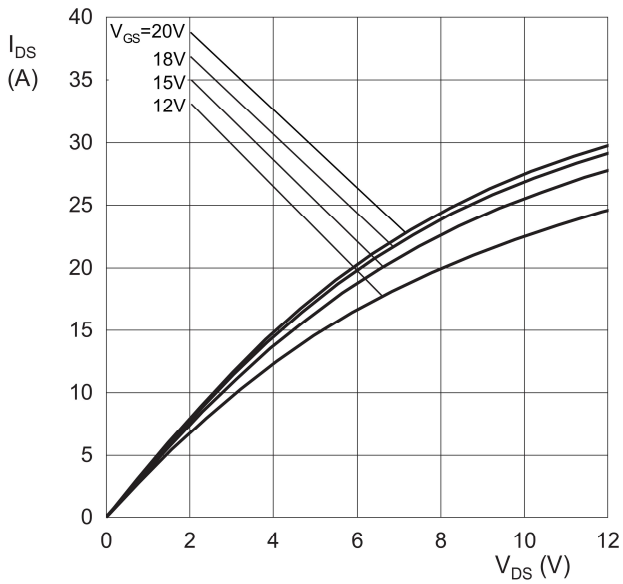

Typ. Drain-source on-state resistance/典型漏源导通电阻
 $R_{DS(on)}=f(I_{DS}); V_{GS}=18\text{V}$

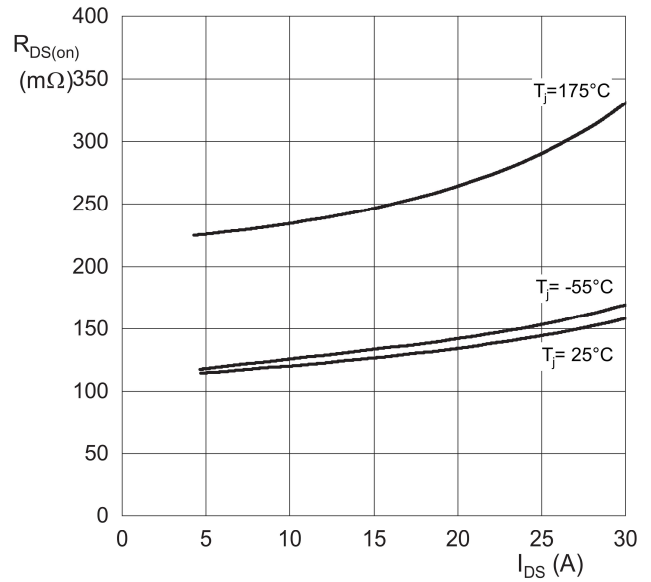

Typ. Drain-source on-state resistance/漏源导通电阻
 $R_{DS(on)}=f(T_J); I_{DS}=10\text{A}$

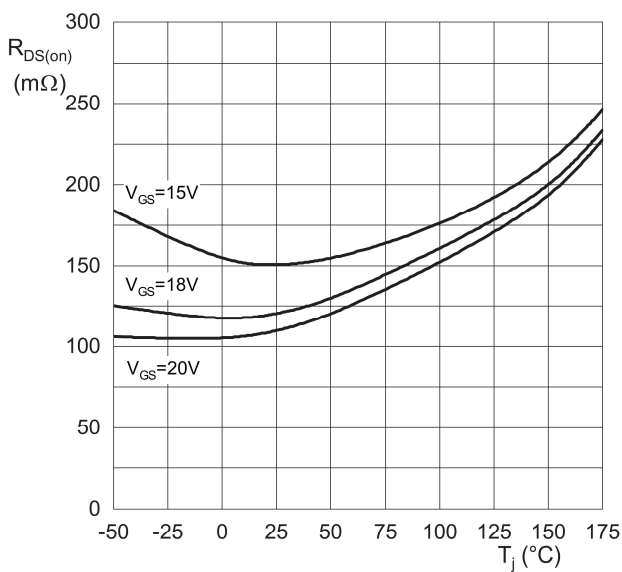

Typ. Transfer characteristics/传输特性
 $I_{DS}=f(V_{GS}); V_{DS}=20\text{V}$

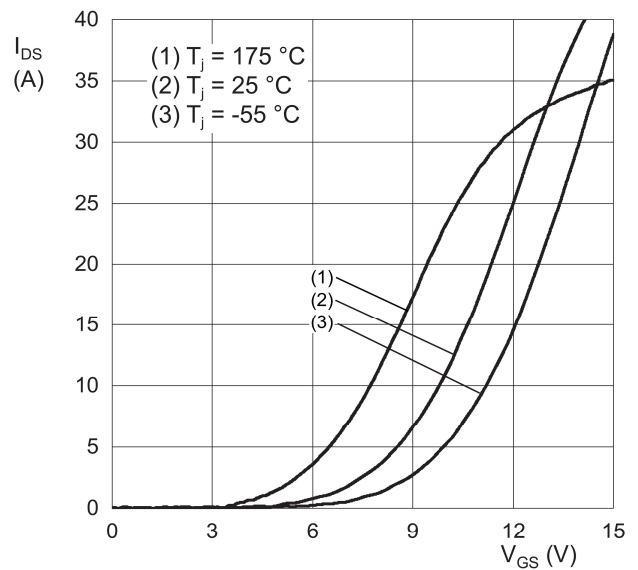

1200V N-Channel SiC MOSFET HC120N120R4R



Typ.Reverse drain current characteristics/典型二极管特性
 $I_{SD}=f(V_{SD})$; $T_C=-55^\circ\text{C}$

Typ.Reverse drain current characteristics/典型二极管特性
 $I_{SD}=f(V_{SD})$; $T_C=25^\circ\text{C}$

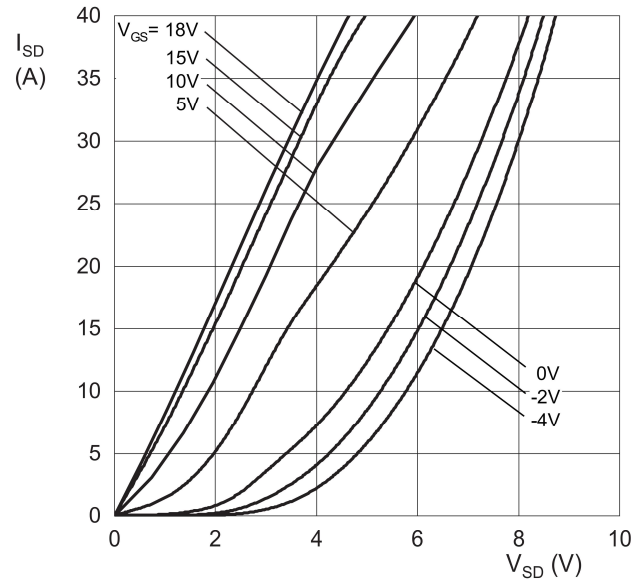
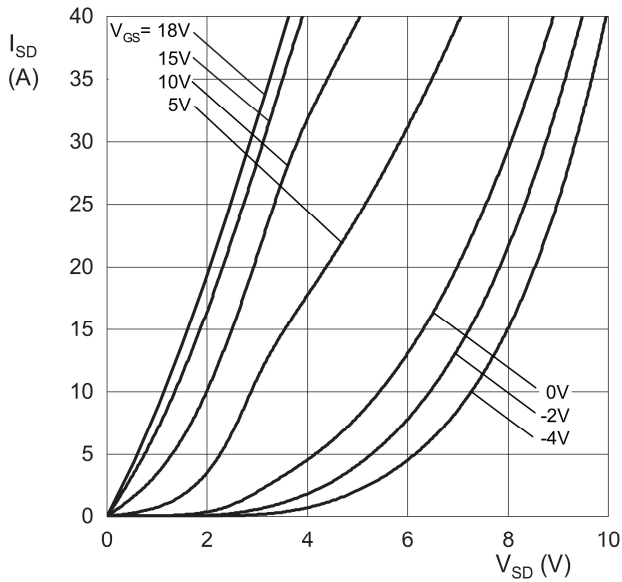

Typ.Reverse drain current characteristics/典型二极管特性
 $I_{SD}=f(V_{SD})$; $T_C=175^\circ\text{C}$

Typ.Gate threshold voltage/门级阈值电压结温特性
 $V_{Gsth}=f(T_j)$; $I_D=2.5\text{mA}$, $V_{DS}=V_{GS}$

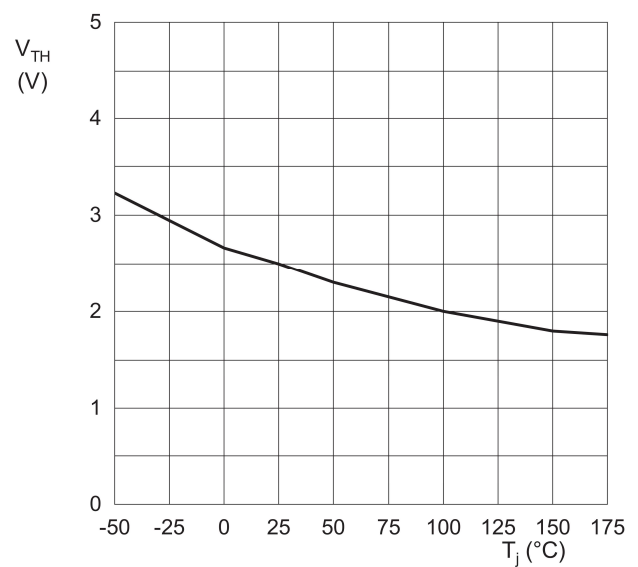
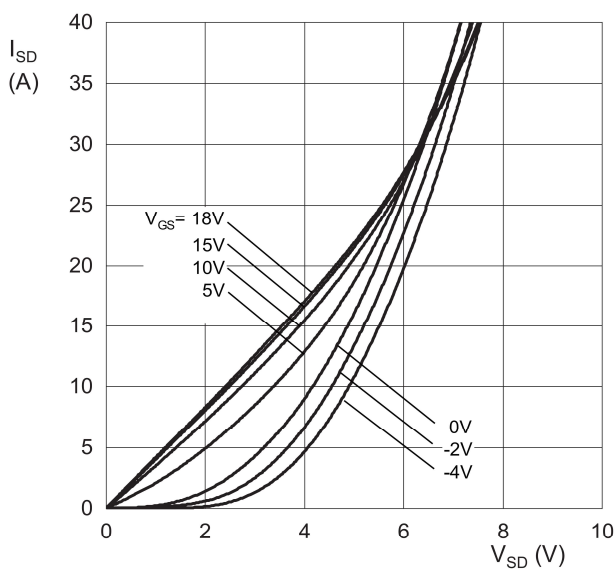

1200V N-Channel SiC MOSFET HC120N120R4R



Typ. Gate charge/典型门级电荷

$V_{GS}=f(Q_G)$; $I_{DS}=10A, I_{GS}=0.1mA, V_{DS}=800V, T_j=25^\circ C$

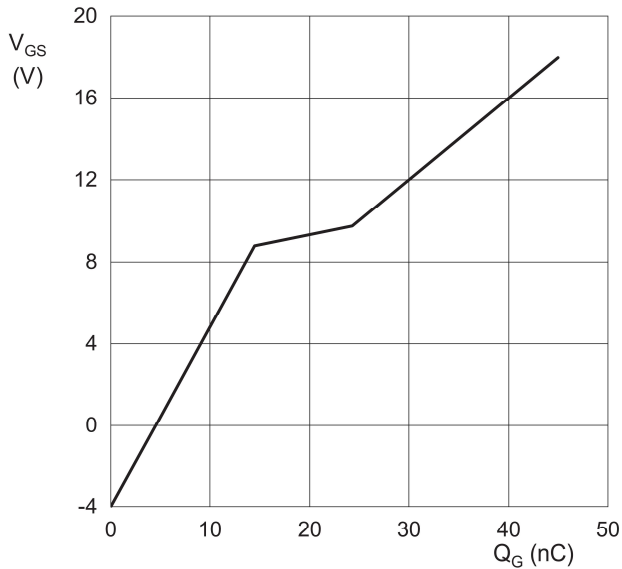

Typ. C_{oss} stored energy/典型 C_{oss} 存储能量

$E_{oss}=f(V_{DS})$; $T_j=25^\circ C$

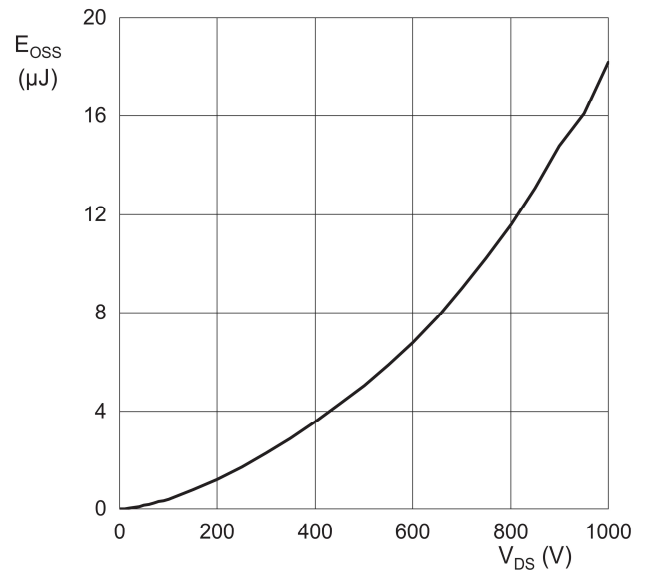

Typ. Capacitances/典型电容特性

$C=f(V_{DS})$; $V_{GS}=0V, T_j=25^\circ C$

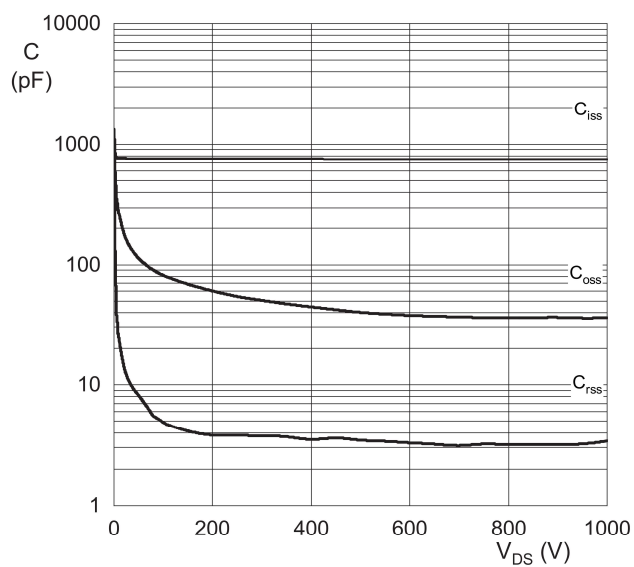

Forward bias safe operating area/安全工作区

$I_{DS}=f(V_{DS})$; $T_c=25^\circ C, D=0$

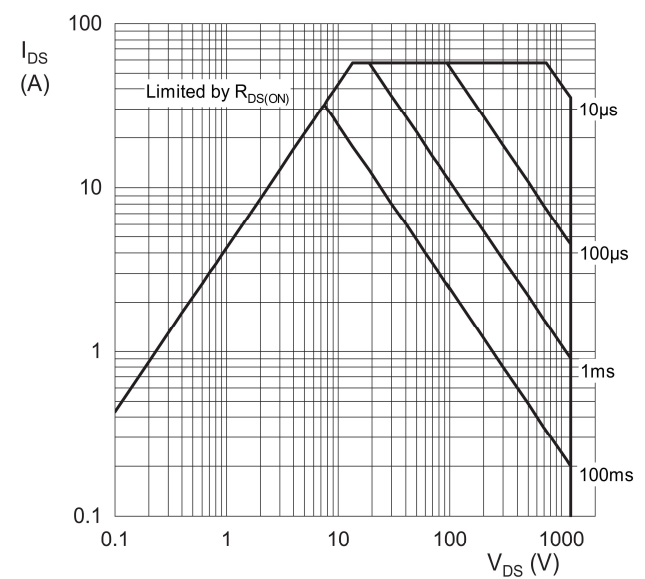

1200V N-Channel SiC MOSFET HC120N120R4R



Typ.Switching Losses vs current /动态损耗-电流特性
 $E=f(I_D)$; $V_{GS}=-4/18V, R_G=5.1\Omega, V_{DD}=800V, T_j=25^\circ C$

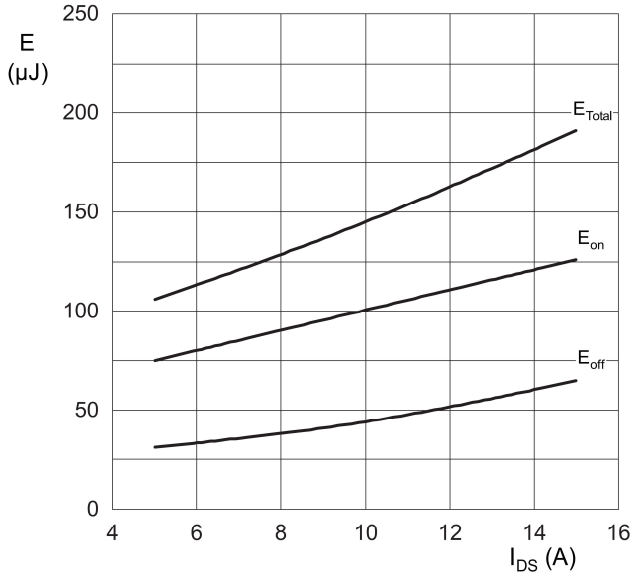

Typ.Switching losses vs temperature/动态损耗-结温特性
 $E=f(T_j)$; $V_{GS}=-4/18V, R_G=5.1\Omega, V_{DD}=800V, I_D=10A$

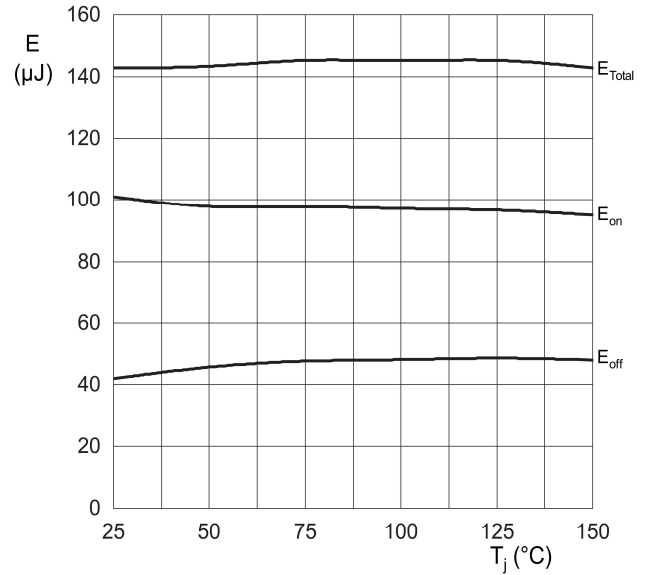

Typ.Switching losses vs resistance/动态损耗-门级电阻特性
 $E=f(R_G)$; $V_{GS}=-4/18V, V_{DD}=800V, I_D=10A, T_j=25^\circ C$

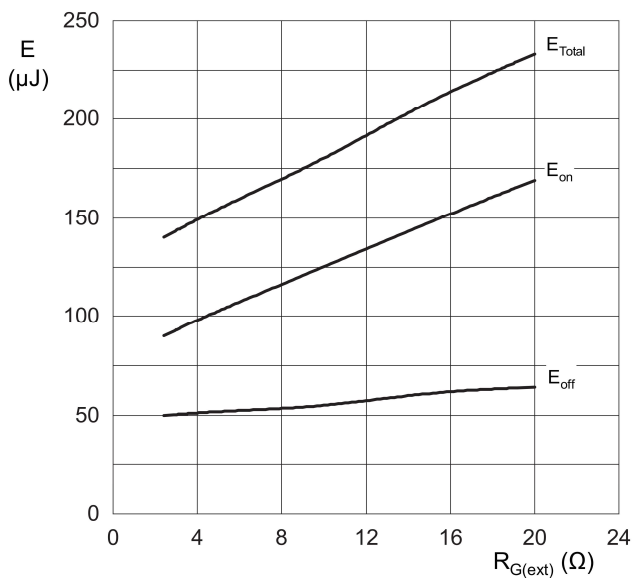

Typ.Switching times vs resistance/开关时间-门级电阻特性
 $t=f(R_G)$; $V_{GS}=-4/18V, V_{DD}=800V, I_D=10A, T_j=25^\circ C$

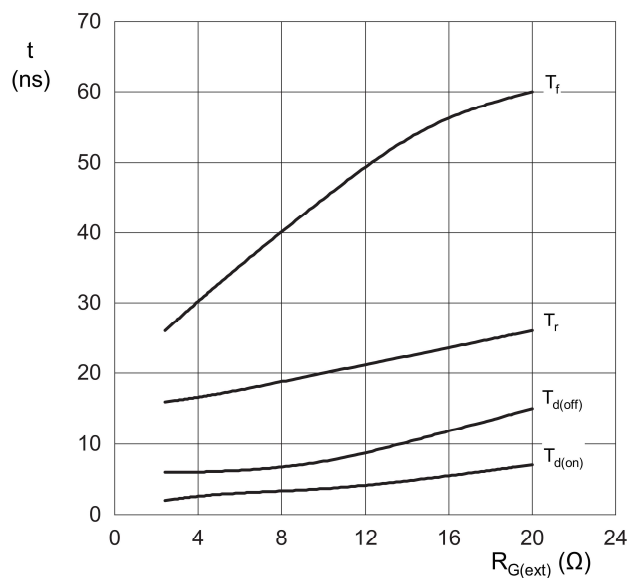

5. Package outline

封装外形

Figure 1. Outline TO247-4L(HC), dimensions in mm/TO247-4L(HC)外形尺寸 (毫米)

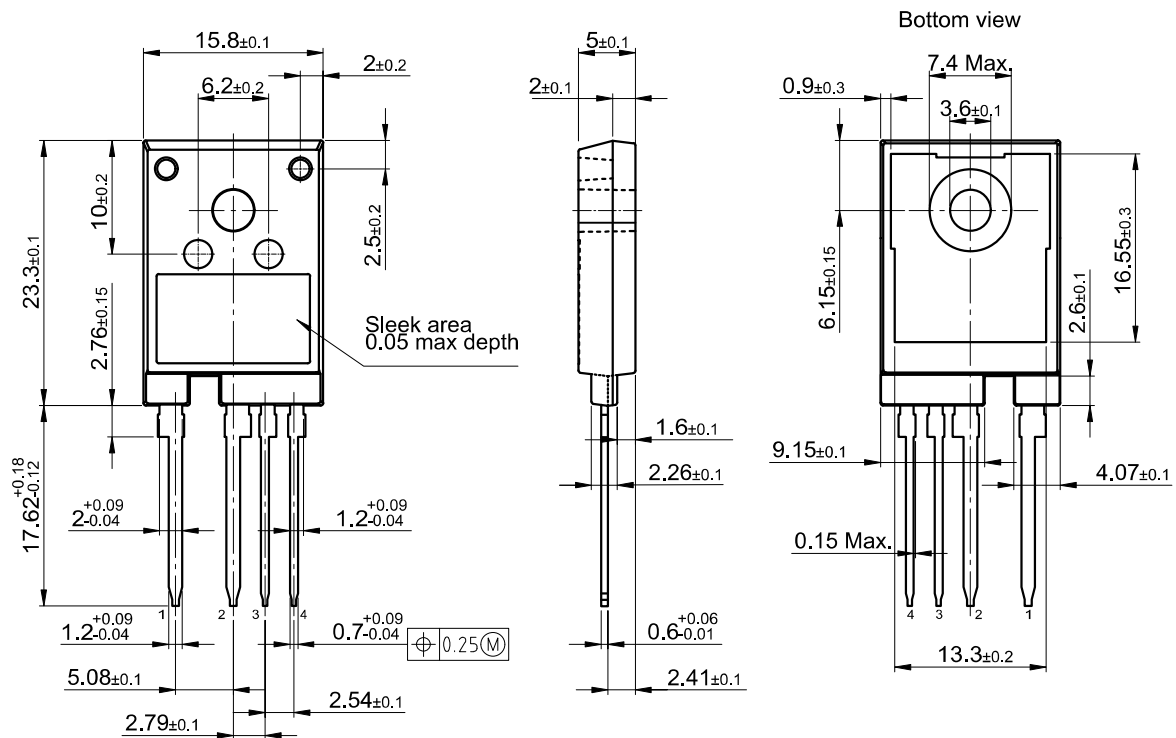

NOTES:

- ALL DIMENSIONS DO NOT INCLUDE MOLD FLASH OR PROTRUSIONS.
- 注: 不计模具飞边或凸起



6. Revision history

Table 6 Date and version number/日期与版本号

Date日期	Revision版本	Changes更改内容
2025-11-15	Rev.G1.0	Target Datasheet (目标规格书)

7. Matters needing attention

Appendix 1. Important Technical Guidance, Application Policy, and Copyright Notice/重要技术指南、应用规范与版权声明

[Data and Design Guidance]

The information provided herein, including typical values and application examples, serves as technical guidance only and should not be construed as a formal guarantee of product characteristics. This documentation is intended for qualified engineering personnel, who bear the ultimate responsibility for evaluating the product's suitability for their specific application and compliance with all industry standards.

[Copyright and Revision Management]

We reserve all rights to the intellectual property contained within this document, and unauthorized reproduction is prohibited. For the sake of continuous improvement, the content is subject to change without prior notice. Designers are obligated to consult and use the latest revision of this datasheet to ensure optimal performance and accuracy in their final product.

[Application Safety and Intellectual Property]

Our product supply does not confer any license or right under any third-party intellectual property. Customers are fully responsible for the patent clearance and functional safety of their end application. Furthermore, this product is not intended for use in life-critical or high-risk systems (such as Class III medical devices or aerospace control) unless explicitly approved by us through a dedicated high-reliability agreement.

【数据与设计指引】

本文件中提供的所有信息，包括任何典型值和应用示例，仅作为技术指引，不应被视为对产品特性的正式保证。本资料专供具备资质的工程技术人员使用，客户的技术部门应对产品在特定应用中的适用性和对所有行业标准的符合性负最终评估责任。

【版权与版本管理】

本文件的所有知识产权和版权均归我方所有，严禁未经授权的复制与传播。为持续优化产品性能，本文件内容可能随时变更，恕不另行通知。设计人员有义务查阅并使用最新的版本数据手册，以确保设计准确性并实现最佳系统性能。

【应用安全与知识产权】

我方提供本产品，不应被视为授予任何第三方知识产权的许可或权利。客户应对其终端应用中的功能安全性、系统鲁棒性以及不侵犯任何第三方专利负全部责任。此外，本产品未被设计或认证用于生命维持或极高风险的关键系统。在将本产品用于此类高可靠性应用之前，客户必须设计充分的冗余和安全机制，并事先与我方签署专门的高可靠性供货协议。

<http://www.hmwsemi.com/>