



钰地半导体
Tudi Semiconductor

Product Specification

TUDI-UCC37321/37322

Single-channel 9A High-Speed Low-Side MOSFET Driver
with Enable Function

网址 www.sztdbdt.com Q

用芯智造 · 卓越品质

semiconductor device
manufacturer

- Design
- research and development
- production
- and sales



Features

- Over-temperature Protection
- Under-voltage Lockout (UVLO)
- Non-overlapped Drive Tech
- Input withstands negative inputs up to 5V
- Available in Green SOP8 and DIP8 Packages
- High Peak Output Current:9A
- High Continuous Output Current:2A
- Wide Supply Voltage Operating Range:4.5V to 15V
- High Capacitive Load Drive Capability10nF in 35ns (typical)
- Short Delay Times:58ns (typical)
- Matched Rise/Fall Times
- Low Output Impedance : 0.5 (typical)
- Low Supply Current

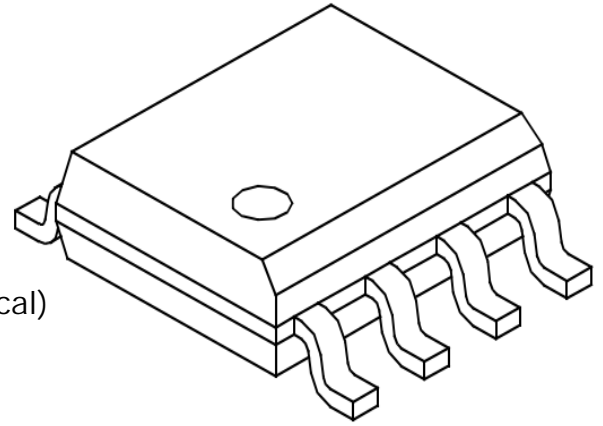

Applications

- Switching Power Supply
- DC/DC Converter
- Motor Controller
- Class D Switching Amplifier
- Line Driver
- Pulse Transf

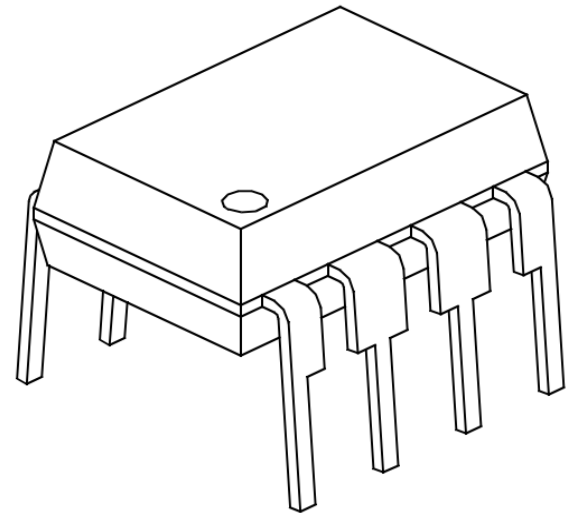

Description

The UCC37321/37322 are single channel, high-current low-side gate drivers capable of driving large MOSFET, SiC, GaN and IGBTs. Unique circuit design enables high speed operation capable of delivering peak currents of 9A into 10,000pF capacitive loads. Improved speed and drive capability are enhanced by matched rise and fall delay times. Dynamic switching losses are minimized with non-overlapped drive techniques. These devices are highly latch-up resistant within their power and voltage ratings. They are not subject to damage when up to 5V of noise spiking (of either polarity) occurs on the ground pin.

The UCC37321/37322 inputs can be driven directly from either TTL or CMOS (1.6V to 15V). In addition, the 300 mV of built-in hysteresis provides noise immunity and allows the device to be driven from slow rising or falling waveforms. Output is held LOW if Input is unbiased or floating.



Pin Diagram

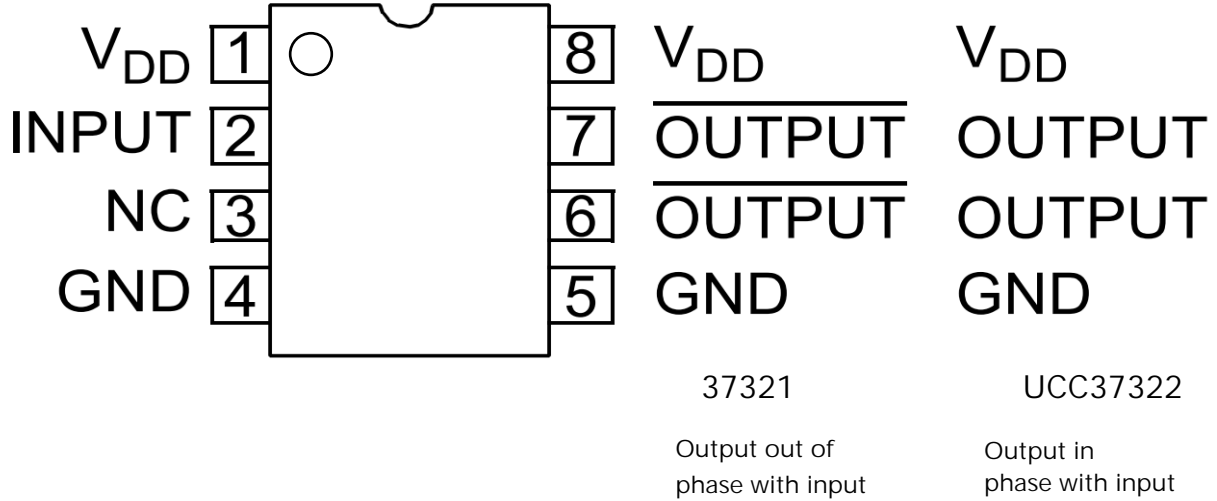

Pin Description (Duplicate pins must both be connected for proper operation.)

Pin	Name	Description
1	VDD	Power Supply
2	INPUT	Control input,TTL/CMOS compatible input
3	NC	No Connection
4	GND	Ground
5	GND	Ground
6	OUTPUT	CMOS push-pull output
7	OUTPUT	CMOS push-pull output
8	VDD	Power Supply
-	PAD	Exposed Metal Pad,electrically isolated

Thermal Data

Parameter	Rating	Unit
Package Thermal Resistance	155(SOP8) 125(DIP8)	°CW



Functional Block Diagram

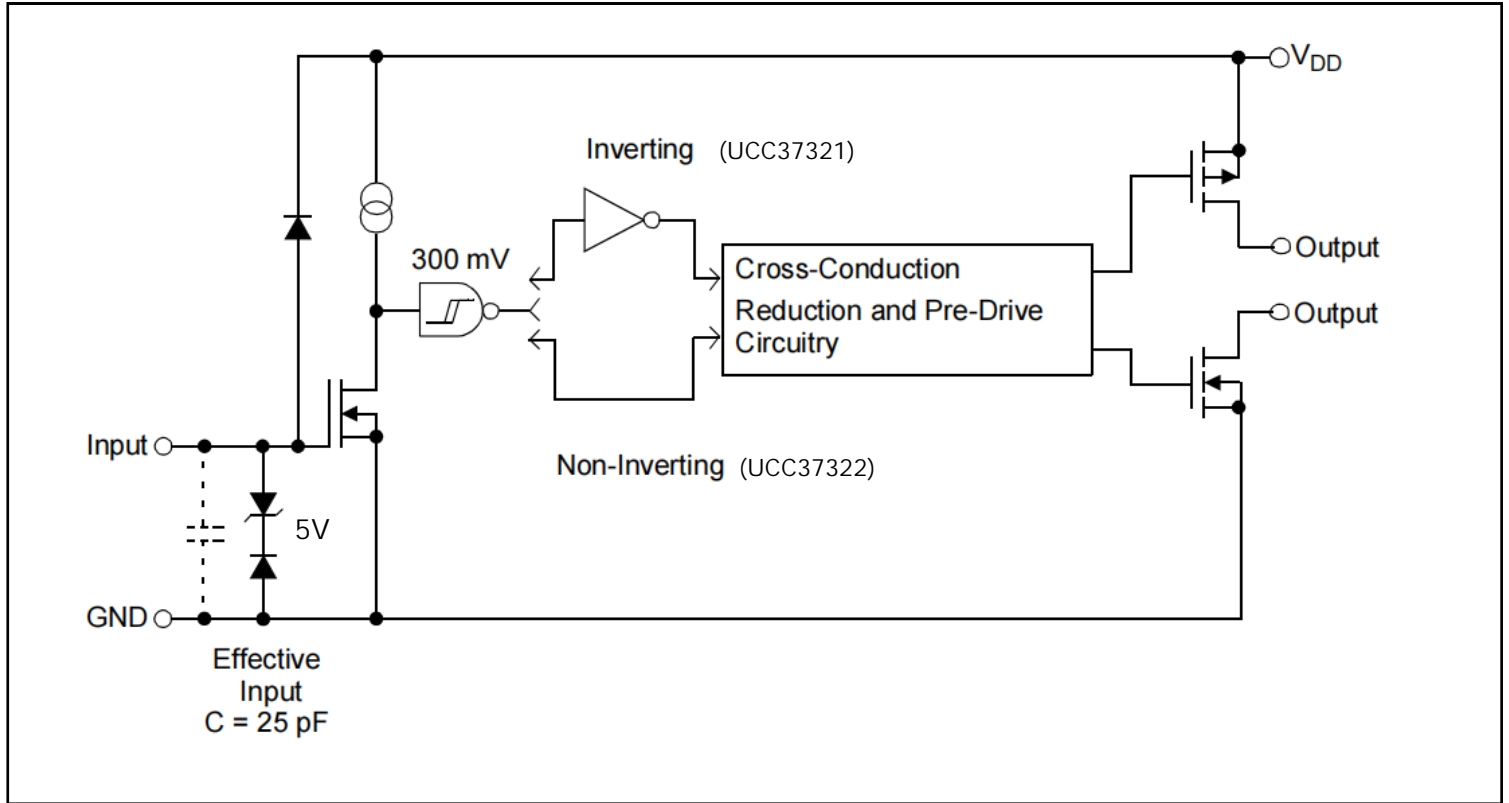

Absolute Maximum Ratings

Parameter	Min	Max	Unit
DC supply voltage V_s		28	V
Operating junction temperature	0	85	
Storage temperature	-55	150	
Maximum input voltage	GND-5	VDD+0.3	V
Combined peak output current		2	A

Note: Stresses exceeding the absolute maximum ratings may damage the device. The device may not function or be operable above the recommended operating conditions and stressing the parts to these levels is not recommended. In addition, extended exposure to stresses above the recommended operating conditions may affect device reliability. The absolute maximum ratings are stress ratings only.



Recommended Operating Conditions

Parameter	Rating	Unit
DC Supply Voltage	4.5-15	V
Operating ambient temperature	0~85	°C

Additional description

Output
MOSFET driver outputs are low-impedance, CMOS push-pull style outputs. The pull-down and pullup devices are of equal strength, making the rise and fall times equivalent. The Output is held LOW if Input is unbiased or floating.
Inputs
MOSFET driver input is a high-impedance, TTL/CMOS compatible input. It also has 300 mV of hysteresis between the high and low thresholds that prevents output glitching even when the rise and fall time of the input signal is very slow.
Supply Input (VDD)
The VDD input is the bias supply for the MOSFET driver and is rated for 4.5V to 15V with respect to the Ground pin. The VDD input should be bypassed with local ceramic capacitors. The value of these capacitors should be chosen based on the capacitive load that is being driven. A value of 1.0 μ F is suggested.
Ground(GND)
Ground is the device return pin. The Ground pin(s) should have a low-impedance connection to the bias supply source return. High peak current flows out the Ground pin(s) when the capacitive load is being discharged.
Exposed Metal Pad
The exposed metal pad of the DFN-S package is not internally connected to any potential. Therefore, this pad can be connected to a ground plane or other copper plane on a Printed Circuit Board (PCB), to aid in heat removal from the package.



Electrical Characteristics

(Typical values are tested at $T_a=25\text{ }^\circ\text{C}$, $V_{DD}=15\text{V}$)

Parameter	Symbol	Conditions	Min.	Typ.	Max.	Unit
switching characteristics						
Rise Time	tR	CL=10,000 pF		35		ns
Fall Time	tF	CL=10,000 pF		36		ns
Turn-On Delay Time	tD1	37321, CL=10,000 pF		58		ns
		37322, CL=10,000 pF		60		ns
Turn-Off Delay Time	tD2	37321, CL=10,000 pF		59		ns
		37322, CL=10,000 pF		63		ns
Input						
Input Signal High Threshold	VIH		1.6			V
Input Signal Low Threshold	VIL				0.7	V
Input Signal Hysteresis	VHYS			0.3		V
Input Signal High Current	IIH	Inverting Input Current, $V_{Inx}=15\text{V}$			0.01	μA
		Non-inverting Input Current, $V_{Inx}=15\text{V}$		88	125	
Input Signal High Current	IL	Inverting Input Current, $V_{Inx}=0\text{V}$		88	125	μA
		Non-inverting Input Current, $V_{Inx}=0\text{V}$			0.01	
output						
High Output Voltage VOH	VoH	DC Test	VDD-0.025			V
Low Output Voltage	VoL	DC Test			0.025	V
Pull-Up Resistance	RoH	Source Current = 10mA		0.83		
Pull-Down Resistance	RoL	Sink Current = -10mA		0.5		
Peak Output Current	Ipk	10V VDD 15V		9.0		A
power supply						
Power Supply Current	Icc	$V_{In}=3\text{V}$		0.85		mA
		$V_{In}=0\text{V}$		0.65		
Operating Voltage Range	VDD		4.5		15	V
Under-Voltage Lockout ON Threshold				3.7	4.1	V
Under-Voltage Lockout Hysteresis				0.5		V
Over-temperature protection						
Thermal Shutdown Threshold				150		
Thermal Shutdown Threshold Hysteresis				25		



Over-temperature protection					
Thermal Shutdown Threshold				150	
Thermal Shutdown Threshold Hysteresis				25	

Switching Time Test Circuit

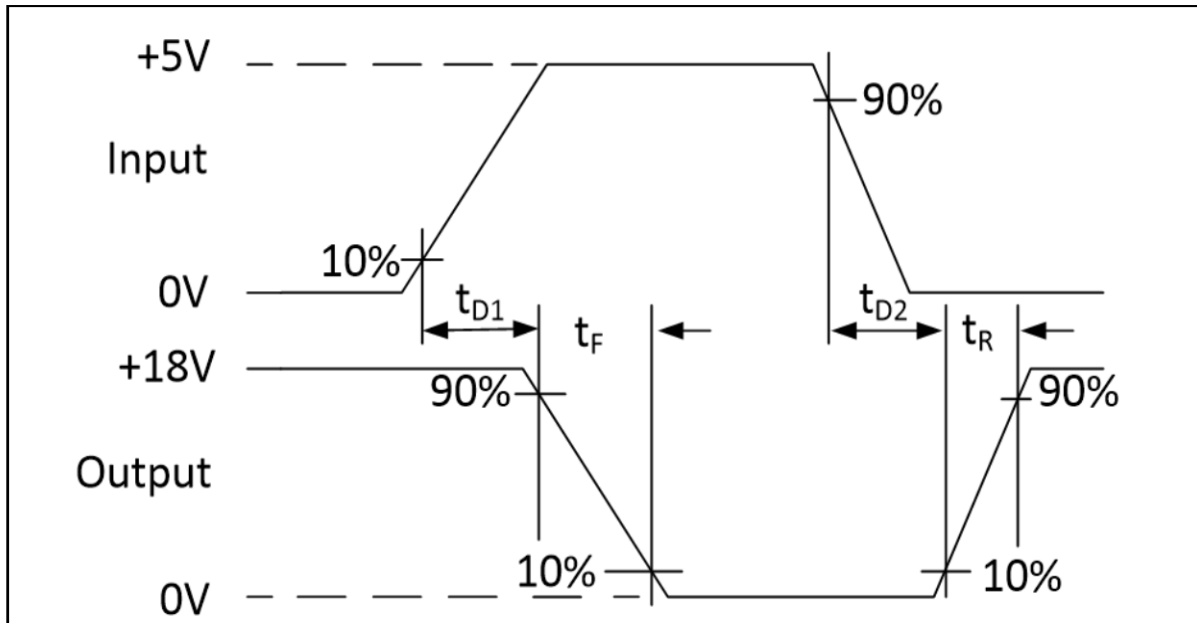

UCC37321 Inverting Driver

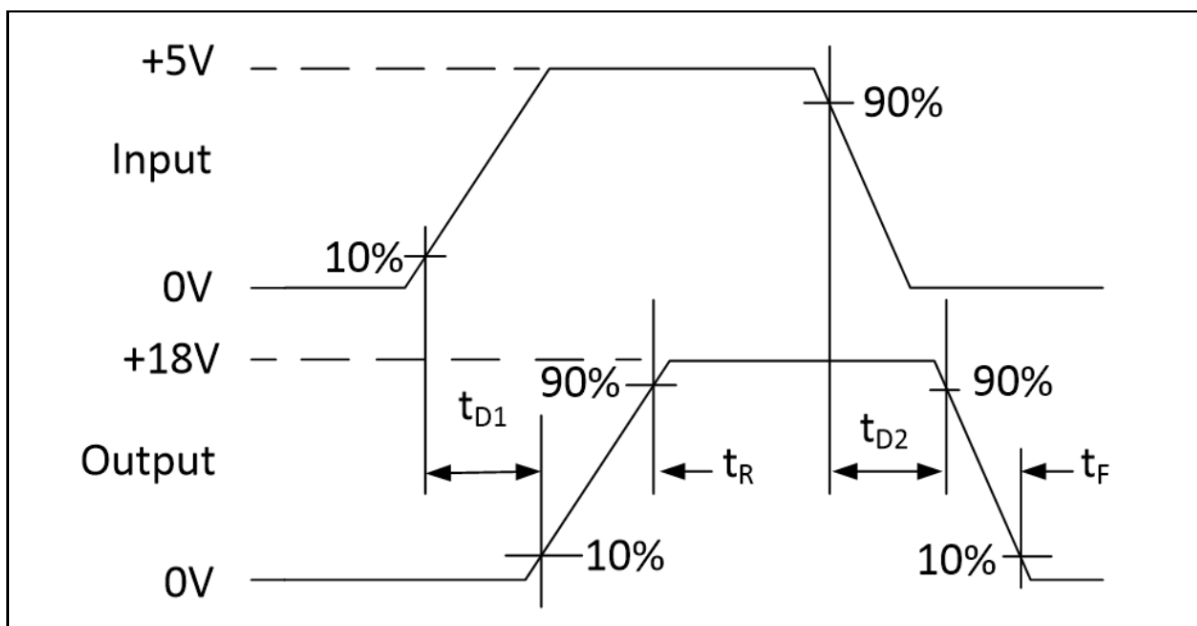

UCC37322 Non Inverting Driver

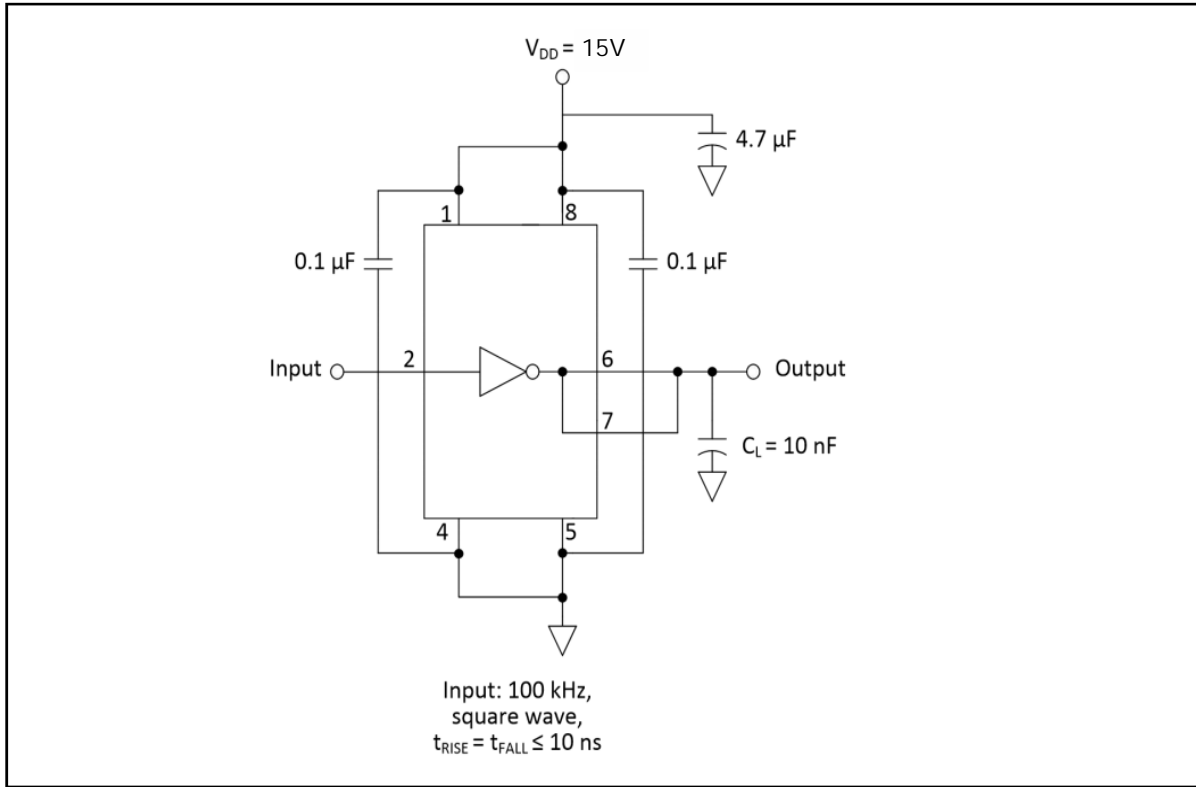

Order information

Order Number	Package	Package Quantity	Marking On The park	Temperature
UCC37321DR-TUDI	SOP8	Tape,Reel,2500	37321	0°C to 85°C
UCC37321P-TUDI	DIP8	Tube,50,A box of 2000	UCC37321P	
UCC37322DR-TUDI	SOP8	Tape,Reel,2500	37322	
UCC37322P-TUDI	DIP8	Tube,50,A box of 2000	UCC37322P	



Package SOP8

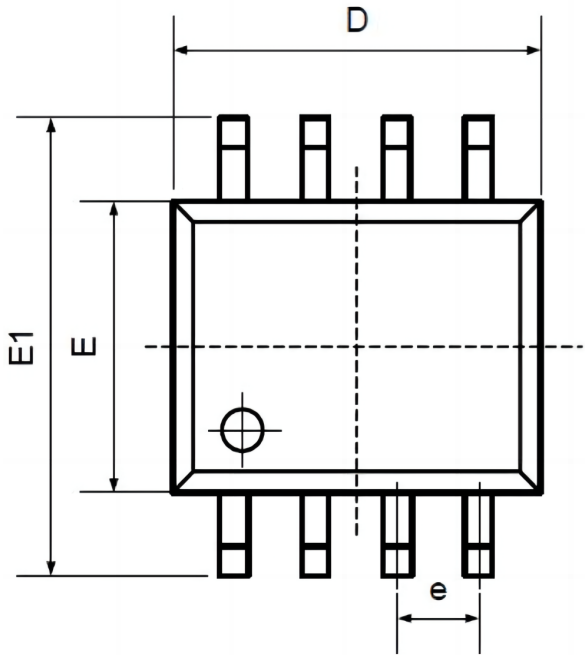

Symbol	Dimensions In Millimeters		Dimensions In Inches	
	Min	Max	Min	Max
A	1.350	1.750	0.053	0.069
A1	0.100	0.250	0.004	0.010
A2	1.350	1.550	0.053	0.061
B	0.330	0.510	0.013	0.020
C	0.190	0.250	0.007	0.010
D	4.780	5.000	0.188	0.197
E	3.800	4.000	0.150	0.157
E1	5.800	6.300	0.228	0.248
e	1.270TYP		0.050TYP	
L	0.400	1.270	0.016	0.050
theta	0°	8°	0°	8°

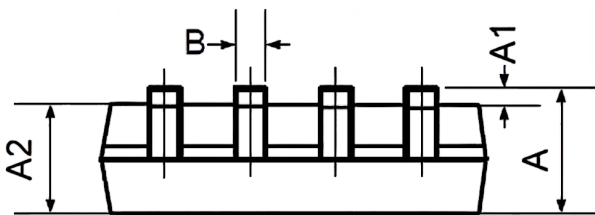



Package DIP8



Symbol	Min	Non	Max
A1	6.28	6.33	6.38
A2	6.33	6.38	6.43
A3	7.52	7.62	7.72
A4	7.80	8.40	9.00
B1	9.15	9.20	9.25
B2	9.20	9.25	9.30
C		5.57	
D		1.52	
E	0.43	0.45	0.47
F		2.54	
G		0.25	
H	1.54	1.59	1.64
I	3.22	3.27	3.32
R		0.20	
M1	9°	10°	11°
M2	11°	12°	13°



Important statement:

- TUDI Semiconductor reserves the right to modify the product manual without prior notice! Before placing an order, customers need to confirm whether the obtained information is the latest version and verify the completeness of the relevant information.
- Any semi-guide product is subject to failure or malfunction under specified conditions. It is the buyer's responsibility to comply with safety standards when using TUDI Semiconductor products for system design and whole machine manufacturing. And take the appropriate safety measures to avoid the potential in the risk of loss of personal injury or loss of property situation!
- TUDI Semiconductor products have not been licensed for life support, military, and aerospace applications, and therefore TUDI Semiconductor is not responsible for any consequences arising from the use of this product in these areas.
- If any or all TUDI Semiconductor products (including technical data, services) described or contained in this document are subject to any applicable local export control laws and regulations, they may not be exported without an export license from the relevant authorities in accordance with such laws.
- The specifications of any and all TUDI Semiconductor products described or contained in this document specify the performance, characteristics, and functionality of said products in their standalone state, but do not guarantee the performance, characteristics, and functionality of said products installed in Customer's products or equipment. In order to verify symptoms and conditions that cannot be evaluated in a standalone device, the Customer should ultimately evaluate and test the device installed in the Customer's product device.
- TUDI Semiconductor documentation is only allowed to be copied without any alteration of the content and with the relevant authorization. TUDI Semiconductor assumes no responsibility or liability for altered documents.
- TUDI Semiconductor is committed to becoming the preferred semiconductor brand for customers, and TUDI Semiconductor will strive to provide customers with better performance and better quality products.