

Surface-Mount Safety Capacitors SMD-X1Y1 Series Product Specification

CUSTOMER: _____

CUSTOMER PART NO.: _____

STE PART NO.: _____

SPECS OF STE: _____

Drafted by	For Customer Approval
GuangQin Li	
Audited by	
Yong Hu	
Approved by	
MingHui Zhao	

[Http://www.songtian.cn](http://www.songtian.cn)

Company and Factory Name: SHANTOU FREE TRADE ZONE SONGTIAN ELECTRONIC TECHNOLOGY CO.,LTD

Add: Songtian Technology East Campus, Songtian Technology West Campus, Free Trade Zone, Shantou, Guangdong, China.

Tel: 86-754-88266532 Fax: 86-754-88266546

E-mail: inquiry@songtian.cn P.O.BOX: 515071

Home page: <http://www.songtian-ste.com>

Design Change Record

No.	Date	Version	Reason For Change	Description
1	2024.10.29	A		First Acknowledgment
2				
3				
4				
5				
6				
7				
8				



1、 Characteristics

- The product height is 2.5mm, significantly reduced compared to traditional lead-type capacitor;
- The product is tape-packaged and suitable for SMT (Surface Mount Technology) automatic insertion soldering;
- SMD ceramic capacitors enable comprehensive surface mounting and miniaturization of end products;
- The product is coated using flame-retardant epoxy resin (compliant with UL 94V-0 flame retardant rating).

2、 Application

- Filtering in AC circuits, primary and secondary coupling in switch-mode power supplies and AC converters;
- The D-A isolation and noise reduction of the transformerless DDA modem;
- These products should not be used in any automotive powertrain systems or safety devices, including battery chargers for electric vehicles and plug-in hybrid electric vehicles.

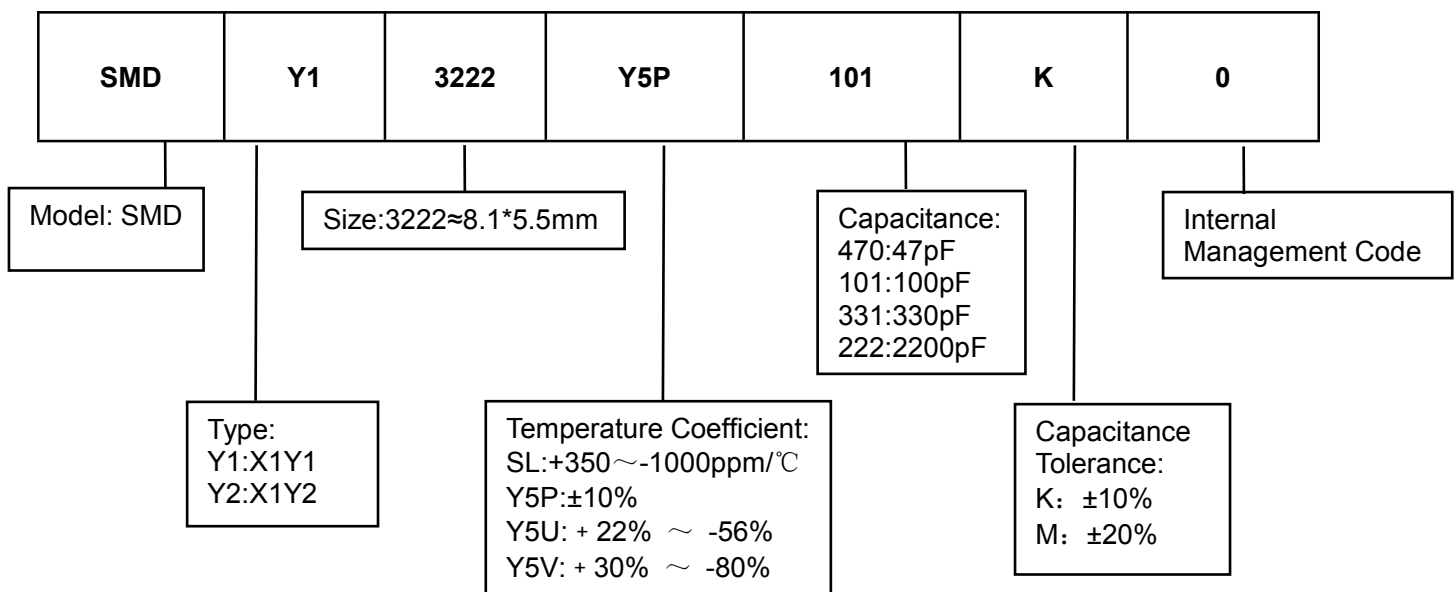

3、 Principles of Part Number Coding



4、 Technical Information

Capacitor Type	Y1 Class
Climatic Category	40/125/21 B
Operating Temperature Range	-40℃～125℃
Rated Voltage	500VAC
Capacitance Range	10pF～2200pF
Dissipation Factor	S(SL) :D.F.≤0.15% B(Y5P), E(Y5U), F(Y5V): D.F.≤2.5%
Withstanding Voltage	4000Vac (r.m.s.)/60sec.
Insulation Resistance	> 10000MΩ(Charging for 60±5 seconds under 500VDC)

5、 Product imprinting

Example	Description		
	1		SongTian Logo
	2	SMD	Product Model: SMD
	3	Y5P	Temperature Characteristics: Y5P
	4	101	Capacitance: 100pF
	5	K	Capacitance Tolerance: K (±10%)
	6	X1Y1	Capacitor Type
	7	760～ 500～	Rated Voltage: 760VAC 500VAC

6、 Safety Certificate

Approval	Organization	Safety Standards	Certificate No.	Rated Voltage
China	CQC	IEC60384-14:2013/ AMD1:2016	CQC24001446247	X1:760VAC、 500VAC、400VAC Y1:500VAC、 400VAC、250VAC
EU	ENEC	IEC60384-14:2023	40058861	
Germany	VDE	IEC60384-14:2023	40058861	
USA / Canada	UL/cUL	UL60384-14	E530201	
International Electrotechnical Commission	IEC-CB	IEC60384-14:2023	DE1-68874/B1	
Korea	KTL	KC60384-1(2015-09), KC60384-14(2015-09)	SU03031-24001	Y1:250VAC

7、 Physical Dimensions (for 3222)

■ Product Dimension

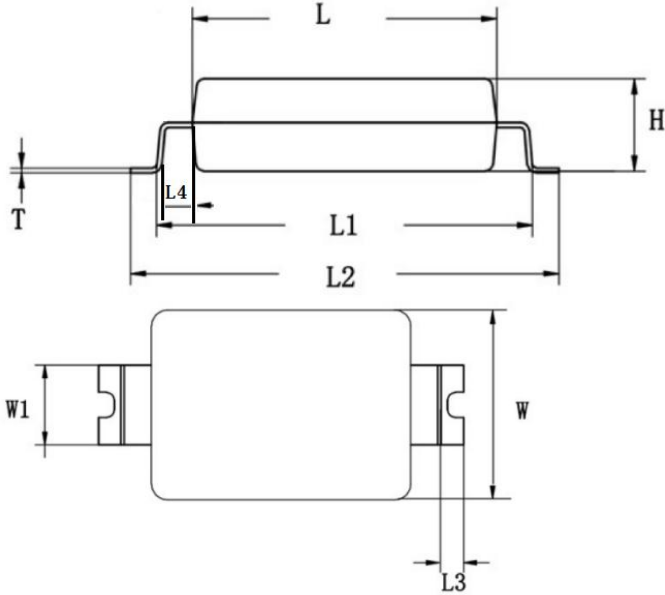

Product Dimension(mm)			
L	8.1±0.3	L1	10.0±0.3
W	5.5±0.3	L2	11.4±0.3
H	2.5±0.3	L3	0.7±0.3
W1	2.5±0.3	T	0.15±0.01
L4	1.1±0.1		

■ Pad Dimension

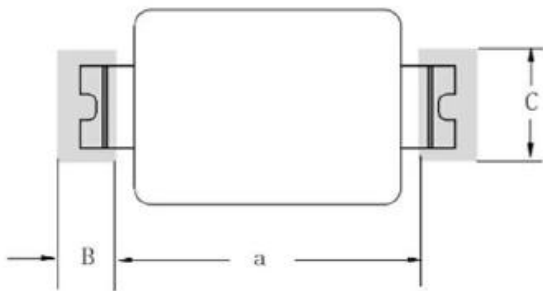

Pad Dimension (mm)	
a	10.0±0.2
b	2.2±0.2
c	3.6±0.2

8、 Specification List

Temperature Characteristics	Nominal Capacitance (pF)	STE Part Number	Temperature Characteristics	Nominal Capacitance (pF)	STE Part Number	
SL	10	SMDY13222SL100K0	Y5P	100	SMDY13222Y5P101K0	
	12	SMDY13222SL120K0		120	SMDY13222Y5P121K0	
	15	SMDY13222SL150K0		150	SMDY13222Y5P151K0	
	18	SMDY13222SL180K0		180	SMDY13222Y5P181K0	
	20	SMDY13222SL200K0		200	SMDY13222Y5P201K0	
	22	SMDY13222SL220K0		220	SMDY13222Y5P221K0	
	27	SMDY13222SL270K0		270	SMDY13222Y5P271K0	
	30	SMDY13222SL300K0		300	SMDY13222Y5P301K0	
	33	SMDY13222SL330K0		330	SMDY13222Y5P331K0	
	39	SMDY13222SL390K0		390	SMDY13222Y5P391K0	
	47	SMDY13222SL470K0		470	SMDY13222Y5P471K0	
	56	SMDY13222SL560K0		Y5U	560	SMDY13222Y5U561M0
	68	SMDY13222SL680K0			680	SMDY13222Y5U681M0
82	SMDY13222SL820K0	820	SMDY13222Y5U821M0			
Y5V	1800	SMDY13222Y5V182M0	1000		SMDY13222Y5U102M0	
	2000	SMDY13222Y5V202M0	1200		SMDY13222Y5U122M0	
	2200	SMDY13222Y5V222M0	1500	SMDY13222Y5U152M0		

9、 Basic Characteristics and Reliability Experiments

No.	Item	Standard	Test Method				
1	Appearance and Dimensions	No obvious defects in appearance and dimensions within the standard range.	Capacitor must be visually inspected for any obvious defects Measure the dimensions using a vernier caliper				
2	Marking	Clear and easily recognizable	Visual inspection				
3	Capacitance	Within the tolerance range	S(SL): The dissipation factor must be measured at 25°C, using a frequency of 1±0.1MHz and a voltage of 1.0V. B(Y5P), E(Y5U), F(Y5V) : The capacitance and dissipation factor must be measured at 25°C, using a frequency of 1±0.1KHz and a voltage of 1.0V.				
4	Dissipation Factor	S(SL) :D.F.≤0.15% B(Y5P), E(Y5U), F(Y5V): D.F.≤2.5%					
5	Insulation Resistance	>10000MΩ	The insulation resistance must be tested after charging at 500VDC for 60±5 seconds.				
6	Dielectric Strength (Between terminals)	No breakdown or arcing	The capacitor withstands the test voltage from Table 1 for 60 seconds between the two leads without damage. (Charging and discharging current does not exceed 50mA) <Table 1> <table border="1" style="margin-left: auto; margin-right: auto;"> <thead> <tr> <th>Type</th> <th>Test Voltage</th> </tr> </thead> <tbody> <tr> <td>X1Y1</td> <td>AC4000V (r.m.s.)</td> </tr> </tbody> </table> Recommended voltage rise time>0.3s.	Type	Test Voltage	X1Y1	AC4000V (r.m.s.)
Type	Test Voltage						
X1Y1	AC4000V (r.m.s.)						
7	Solderability	The lead surface requires solder coverage on over 75% of the area.	Solder temperature: 245±3°C Dipping time: 3±0.3 seconds Solder composition: Sn98Ag2				

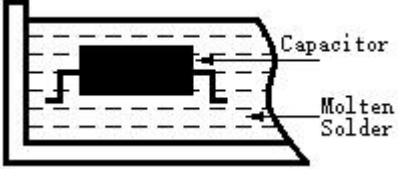
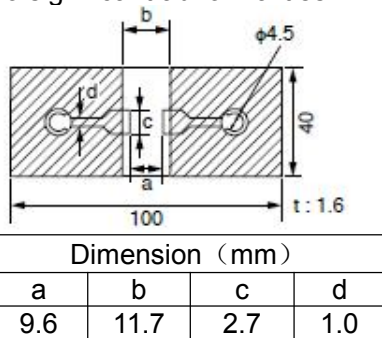
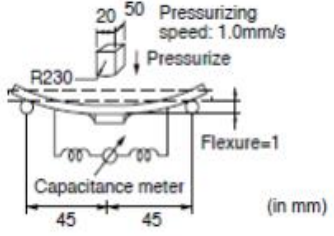
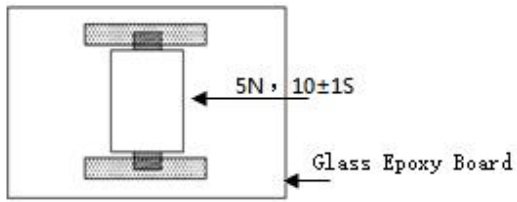
No.	Item	Standard	Test Method									
8	Appearance	No visual damage	Pre-treatment: The product is placed at 150 +0/-10°C for 60±5 minutes, followed by a 24±2 hour placement at room temperature. (applicable for B/E material) After pre-treatment according to the methods in the table, immerse the capacitor into molten solder at 260+5°C for 10±1 seconds, with an immersion speed of 25±2.5mm/s. Afterward, allow it to stand at room temperature for 24±2 hours before testing.									
	Capacitance Change Rate	Within ±10%										
	Solder Heat Resistance Withstanding Voltage	4KVAC/60S Pass										
			 <table border="1" data-bbox="949 698 1465 817"> <thead> <tr> <th>Item</th> <th>Temperature</th> <th>Time</th> </tr> </thead> <tbody> <tr> <td>1</td> <td>100~120°C</td> <td>1min</td> </tr> <tr> <td>2</td> <td>170~200°C</td> <td>1min</td> </tr> </tbody> </table>	Item	Temperature	Time	1	100~120°C	1min	2	170~200°C	1min
Item	Temperature	Time										
1	100~120°C	1min										
2	170~200°C	1min										
9	Appearance	No visual damage	Solder the capacitor to the test fixture and subject it to vibrations at 10Hz-55Hz-10Hz with a total amplitude of 1.5mm, repeating the vibration cycle within 1 minute. Unless otherwise specified, check for mechanical damage after operating in mutually perpendicular directions for a total of 6 hours (2 hours each direction)									
	Capacitance	Within tolerance range										
	Dissipation Factor	S(SL):D.F.≤0.15% B(Y5P)/E(Y5U)/F(Y5V): D.F.≤2.5%										
10	Plate flexural test	no significant abnormalities	Weld the capacitor to the test fixture as shown in the diagram and apply the specified test force. Use reflow soldering with care to prevent heat-related damage to the capacitor.									
		 <table border="1" data-bbox="502 1339 901 1444"> <thead> <tr> <th colspan="4">Dimension (mm)</th> </tr> <tr> <th>a</th> <th>b</th> <th>c</th> <th>d</th> </tr> </thead> <tbody> <tr> <td>9.6</td> <td>11.7</td> <td>2.7</td> <td>1.0</td> </tr> </tbody> </table>		Dimension (mm)				a	b	c	d	9.6
Dimension (mm)												
a	b	c	d									
9.6	11.7	2.7	1.0									
												
11	Welding Strength (Cutting testing)	No pin misalignment or other adverse events	Weld the capacitor onto the test fixture as shown in the diagram, apply a 5N pushing force in the direction of the arrow. Solder the capacitor using reflow soldering and handle with care to avoid damage from heat shocks.									
												
12	Appearance	No visual damage	Capacitor kept at 40±2°C, 90-95% RH for 500±12 hours. Post-test: Store capacitor at room temperature for 1-2 hours.									
	Steady-State Humidity-Heat Capacitance Change Rate	S(SL)/B(Y5P)/ E(Y5U)/F(Y5V): ≤±15%										
	Insulation Resistance	>5000MΩ										
	Withstanding Voltage	4KVAC/60S Pass										

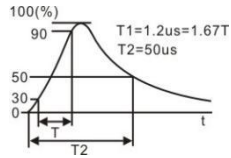
No.	Item	Standard	Test Method																									
13	Humidity Resistance	Appearance	No visual damage																									
		Capacitance Change Rate	S(SL)/B(Y5P)/ E(Y5U) /F(Y5V): $\leq \pm 15\%$																									
		Insulation Resistance	$>5000M\Omega$																									
		Withstanding Voltage	4KVAC/60S Pass																									
<p>Capacitor maintained at a temperature of $40\pm 2^{\circ}C$ and a relative humidity of 90-95% under rated voltage for 500 ± 12 hours. Post-test handling: The capacitor must be stored at room temperature for 1-2 hours.</p>																												
14	Durability	Appearance	No visual damage																									
		Capacitance Change Rate	Within $\pm 20\%$																									
		Insulation Resistance	$>5000M\Omega$																									
		Withstanding Voltage	4KVAC/60S Pass																									
<p>Peak Voltage: Each test capacitor withstands three instances of 8KVDC peak voltage, followed by a life test. Conduct a 1000+48/-24-hour test at $125\pm 2/-0^{\circ}C$ with relative humidity not exceeding 50%, using voltages specified in the table.</p> <div style="border: 1px solid black; padding: 5px; width: fit-content; margin: 10px auto;"> <p style="text-align: center;">Voltage</p> <p style="text-align: center;">$1.7*U_R$, increase the voltage by AC1000V every hour for 0.1 seconds."</p> </div> <p>Post-test Handling: The capacitor must be stored at room temperature for 1 to 2 hours.</p> 																												
15	Flame Retardance Test	The duration of flame application on the tested capacitor must not exceed the specified values in the table. Burning droplets or falling hot particles should not ignite a tissue paper	Capacitors under test should be positioned at the most flammable location in the flame and exposed once, meeting Class B requirements;																									
			<table border="1" style="width: 100%; border-collapse: collapse; text-align: center;"> <thead> <tr> <th rowspan="2">Class</th> <th colspan="4">Capacitor Volume (mm³)</th> <th rowspan="2">Maximum Burning time (s)</th> </tr> <tr> <th>Volume <250</th> <th>250< Volume ≤500</th> <th>500< Volume ≤1750</th> <th>Volume >1750</th> </tr> </thead> <tbody> <tr> <td>A</td> <td>15</td> <td>30</td> <td>60</td> <td>120</td> <td>3</td> </tr> <tr> <td>B</td> <td>10</td> <td>20</td> <td>30</td> <td>60</td> <td>10</td> </tr> <tr> <td>C</td> <td>5</td> <td>10</td> <td>20</td> <td>30</td> <td>30</td> </tr> </tbody> </table>	Class	Capacitor Volume (mm ³)				Maximum Burning time (s)	Volume <250	250< Volume ≤500	500< Volume ≤1750	Volume >1750	A	15	30	60	120	3	B	10	20	30	60	10	C	5	10
Class	Capacitor Volume (mm ³)				Maximum Burning time (s)																							
	Volume <250	250< Volume ≤500	500< Volume ≤1750	Volume >1750																								
A	15	30	60	120	3																							
B	10	20	30	60	10																							
C	5	10	20	30	30																							
16	High-Temperature Storage	Appearance	No visual damage																									
		Capacitance Change Rate	Within $\pm 20\%$																									
		Insulation Resistance	$>5000M\Omega$																									
		Withstanding Voltage	4KVAC/60S Pass																									
<p>Store the capacitors in an environment at $125\pm 5^{\circ}C$ for 1000 hours Pre-test Preparation: Capacitors must be stored at $125\pm 2^{\circ}C$ for 1 hour, followed by 24 ± 2 hours at room temperature before the initial measurement. Post-test Handling: Capacitors must be stored at room temperature for 24 ± 2 hours.</p>																												
17	Low-Temperature Storage	Appearance	No visual damage																									
		Capacitance Change Rate	Within $\pm 20\%$																									
		Insulation Resistance	$>5000M\Omega$																									
		Withstanding Voltage	4KVAC/60S Pass																									
<p>Storage at $-40\pm 5^{\circ}C$ for 1000 hours. Pre-test Preparation: Capacitors must be stored at $125\pm 2^{\circ}C$ for 1 hour, followed by 24 ± 2 hours at room temperature before the initial measurement. Post-test Handling: Capacitors must be stored at room temperature for 24 ± 2 hours.</p>																												
18	High-Low Temperature Shock	Appearance	No visual damage																									
		Capacitance Change Rate	Within $\pm 20\%$																									
		Insulation Resistance	$>5000M\Omega$																									
		Withstanding Voltage	4KVAC/60S Pass																									
<p>Test the capacitors in the order specified in the table for one cycle, and repeat the process for a total of 5 cycles</p> <p>Temperature Cycle</p> <table border="1" style="width: 100%; border-collapse: collapse; text-align: center;"> <thead> <tr> <th>Order</th> <th>($^{\circ}C$)</th> <th>(min)</th> </tr> </thead> <tbody> <tr> <td>1</td> <td>-40 +0/-3</td> <td>30</td> </tr> <tr> <td>2</td> <td>+25 +0/-3</td> <td>3</td> </tr> <tr> <td>3</td> <td>125 +3/-0</td> <td>30</td> </tr> <tr> <td>4</td> <td>+25 +0/-3</td> <td>3</td> </tr> </tbody> </table> <p>Pre-test Preparation: Capacitors must be stored at $125\pm 2^{\circ}C$ for 1 hour, followed by 24 ± 2 hours at room temperature before the initial measurement. [Post-test Handling]: Capacitors must be stored at room temperature for 24 ± 2 hours.</p>				Order	($^{\circ}C$)	(min)	1	-40 +0/-3	30	2	+25 +0/-3	3	3	125 +3/-0	30	4	+25 +0/-3	3										
Order	($^{\circ}C$)	(min)																										
1	-40 +0/-3	30																										
2	+25 +0/-3	3																										
3	125 +3/-0	30																										
4	+25 +0/-3	3																										

10、 Packing Instructions (for 3222)

■ Description of tape and reel package method

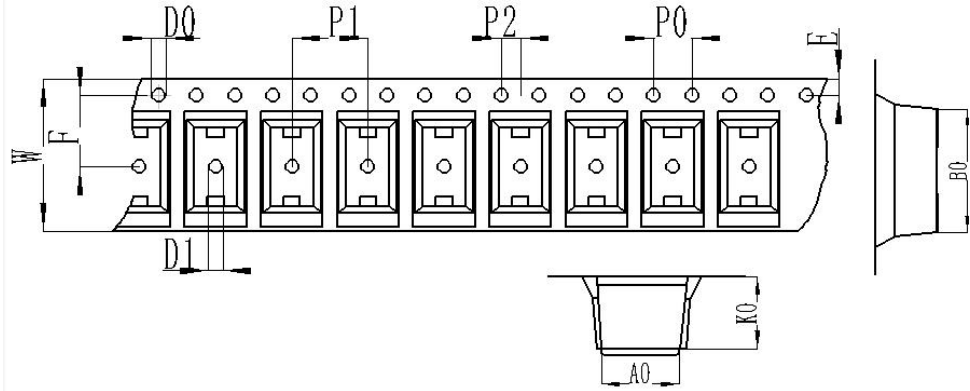

unit: mm

A0	B0	K0	P0	P1	P2
6.5±0.1	12.2±0.1	2.8±0.1	4.0±0.1	8.0±0.1	2.0±0.05
W	E	F	D0	D1	Components/Reel
24.0±0.2	1.75±0.1	7.5±0.1	1.5±0.1	1.5±0.1	4000pcs

■ 15-inch reel size

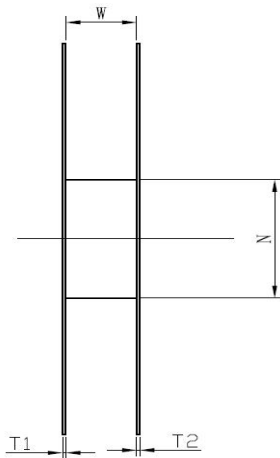

Unit: mm

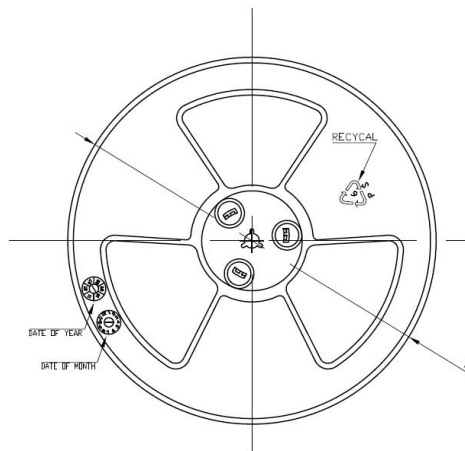

SPEC	24
E±0.5	2.3
F±0.5	10.75
W±0.2	24.4
T1±0.3	2.2
T2±0.3	2.2
A+0/-2	φ380
N±3.0	φ100
D±0.3	13.3

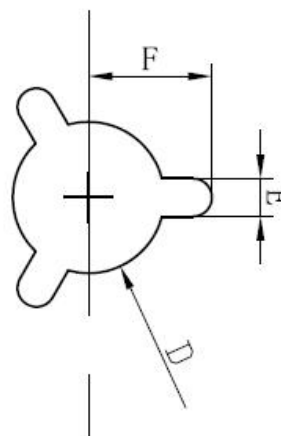

■ Packing Carton

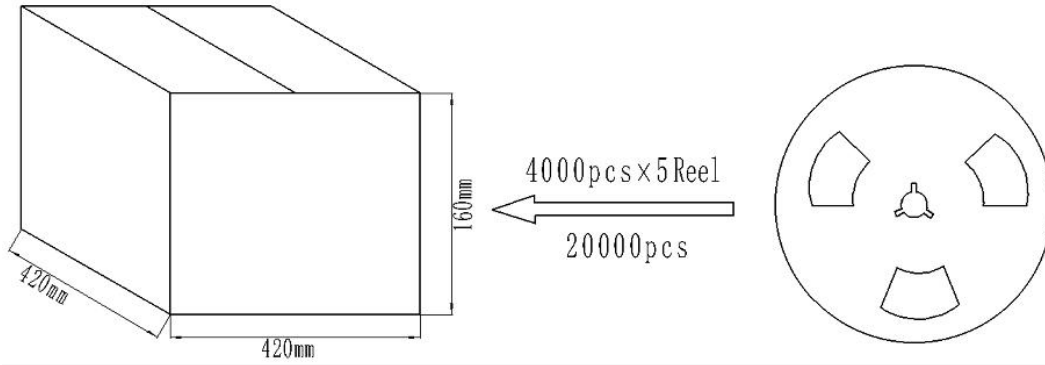

11、 Soldering Instruction

■ Reflow Soldering Curve

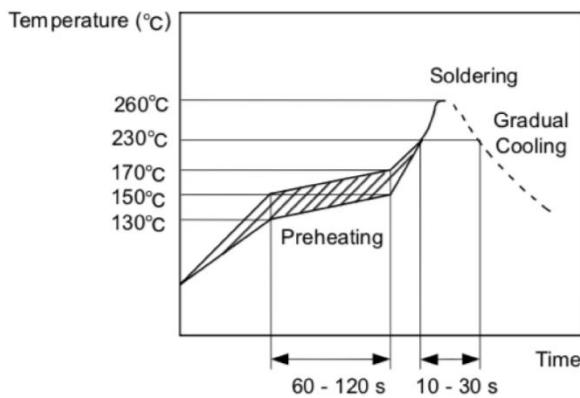

■ Wave Soldering Curve

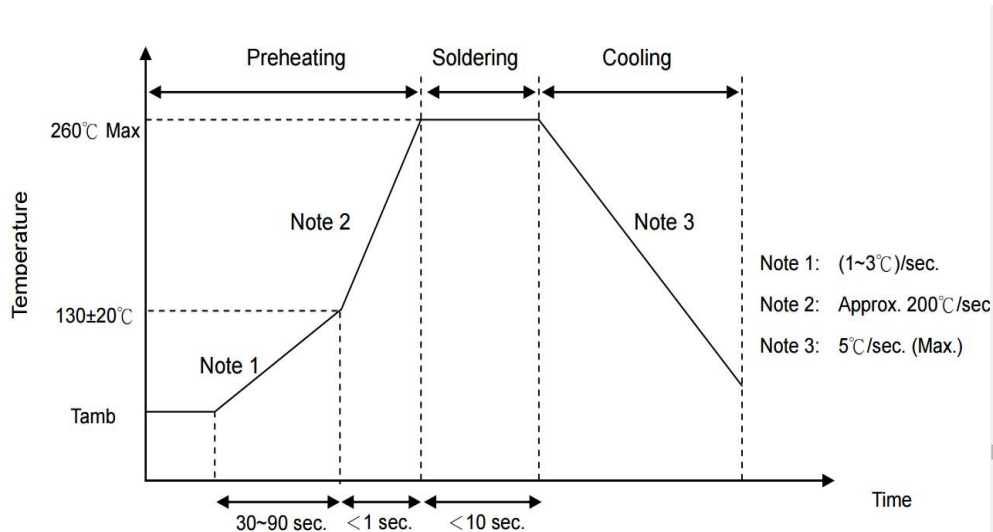

■ Soldering Conditions

Item	Condition
Soldering Iron Tip Temperature	400°C(max.)
Soldering Time	3.5 sec(max.)
Soldering Iron Power	50W(max.)

12、 Storage Environment

- The insulation coating of the capacitor cannot form a perfect seal; therefore, avoid using or storing the capacitor in corrosive environments, especially where chloride gas, sulfide gas, acids, alkalis, salts, or similar substances are present, and minimize exposure to moisture. Verify that cleaning, soldering, or forming processes do not affect the product quality before these processes are performed.
- This is an MSL3 product. Hence, to prevent moisture absorption, the capacitor is packaged in a moisture-proof sealed bag.
- The capacitor should be stored and used within the following conditions for up to 6 months after delivery:
 - Temperature: Below 30°C
 - Humidity: 60%RH max
- After opening the moisture-proof packaging, solder the capacitor within 168 hours. Post-opening, store the capacitor in a moisture-proof bag with desiccant, along with the information card, and maintain the aforementioned conditions.
- If the storage period exceeds 6 months or the sealed bag is opened, perform baking (60°C, 168 hours) before soldering.

13、 Usage Precaution



Warning

- Operating Voltage:

Ensure that the applied voltage (V_{p-p} or V_{o-p} with DC bias) stays within the rated voltage range when using DC-rated capacitors in AC or ripple current circuits. Temporary abnormal voltages may occur during start-up or shutdown due to resonance or switching. Use capacitors within the rated voltage range to accommodate such conditions.

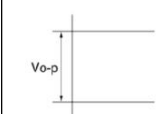
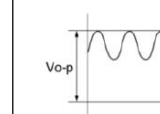
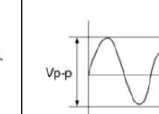
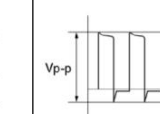
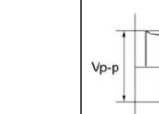
Voltage	VDC	VDC+VAC	VAC	Pulse Voltage (1)	Pulse Voltage (2)
Position Measurement					

- Operating Temperature and Self-Heating (Applicable to B/E Characteristics)

The capacitor's surface temperature should be kept below the upper limit of its rated operating temperature range. Consider the self-heating of the capacitor, which may occur in high-frequency

currents, pulse currents, etc. External voltage should not allow the temperature rise due to self-heating to exceed a range of 20°C around 25°C. Use a $\phi 0.1\text{mm}$ low heat capacity (K) thermocouple for measurements, and ensure that the capacitor is not influenced by heat dissipation from other components or fluctuations in ambient temperature. Overheating may lead to a decrease in capacitor characteristics and reliability.

(Do not conduct measurements when the cooling fan is running, as it may affect the accuracy of the measurement).

■ Test Conditions for Withstand Voltage

Test Equipment:

The AC withstand voltage test equipment should be capable of generating a sine wave similar to 50/60Hz. Applying deformed sine waves or overload voltages exceeding the specified voltage may result in failure.

Voltage Application Method:

When applying the withstand voltage, the leads or terminals of the capacitor should be securely connected to the output terminals of the withstand voltage test equipment. Gradually increase the voltage from near zero to the test voltage. If the test voltage is not gradually increased from near zero but directly applied to the capacitor, it should include *zero crossing during application. At the end of the test, the test voltage should be reduced to near zero before removing the capacitor leads or terminals from the output terminals of the withstand voltage test equipment. If the test voltage is not gradually increased from near zero but directly applied to the capacitor, surges may occur, leading to failure.

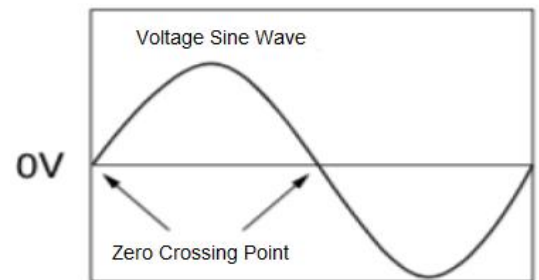

*Zero crossing refers to the position where the sine wave voltage passes through 0V. See the figure on the right.

- Repeated withstand voltage tests conducted by users may damage the capacitor, so capacitors tested after the test should not be used as qualified products again.

■ Fail-Safe Design

If the capacitor is damaged, it can lead to a short circuit fault. Be sure to provide appropriate automatic fault protection functions, such as fuses, on the product to prevent electric shock, fire, or smoke.

■ Vibration and Shock

During use, avoid excessive shocks or vibrations that may expose the capacitor or pins, and prevent any crushing, bending, or external impact.

■ Bonding, Molding, or Coating

Before bonding, molding, or coating this product, verify through testing the performance of bonding, molding, or coating the product in the designated equipment to ensure that these processes do not affect the quality of the capacitor.

If there are drying/adhesive hardening conditions and the molding resin contains organic solvents (ethyl acetate, methyl ethyl ketone, toluene, etc.), SMD is not suitable. Organic solvents may cause damage to the resin on the outer layer of the capacitor, resulting in cases of damage or short circuits.

During temperature cycling, changes in the thickness of adhesives, molding resins, or coatings may lead to cracking of the outer shell resin and/or cracking of ceramic components.

- Capacitors mounted on PCBs require the PCB pads to align with the capacitor pins for proper soldering. Otherwise, poor soldering between the capacitor and PCB may occur, leading to deformation of the capacitor pins or damage to the body, resulting in capacitor damage. Capacitors soldered to PCBs should not be forcibly moved or have the body tilted.

- Consult our technical personnel in advance when performing resin molding on capacitors.

■ Restricted Applications

Contact us before using our products in the following applications that require exceptionally high reliability to prevent defects that could directly cause harm to third parties' life, body, or property.

Aircraft Equipment

Aerospace Equipment

Submersible Equipment

Power Plant Control Equipment

Medical Equipment

Transportation Equipment

Traffic Signal Equipment

Disaster Prevention/Crime Prevention Equipment

Data Processing Equipment affecting the public

Applications with similar complexity and/or reliability requirements.