

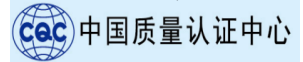

产品规格书



产品名称: 5mm (940) 红外发射管

Product Name: 5mm (940) Infrared emission tube

产品型号: 5A2L-10

Product model: 5A2L-10

发布日期: 2023 年 5 月

Release date: May 2023



环保产品, 符合 ROHS 要求

Environmental protection products meet ROHS requirements

湿气敏感性等级 (MSL) : 4-5 级

Moisture sensitivity level (MSL) : 4-5 levels

EIA 规范标准包装

EIA standard packaging

使用寿命长

long service life

高能效、启动快

High energy efficiency, fast startup

低电压有流驱动

Low voltage current drive



目录 (catalogue)

1: 应用领域.....	3
Application area	
2: 外观与尺寸.....	4
Appearance and size	
3: 电性参数.....	5, 6,
Electrical parameters	
4: 可靠性实验.....	7
Reliability experiment	
5: 包装与标签说明.....	8
Packaging and labeling instructions	
6: 焊接指导.....	9
Welding guidance	
7: 使用包装注意事项.....	10, 11, 12
Precautions for using packaging	

公司名称: 广西桂光半导体有限公司

公司网址: www.guiguanglight.com

公司地址: 广西壮族自治区崇左市扶绥县新宁镇空港大 46 号青年创业基地 4 号楼厂房



一、应用领域 Application area

* 汽车电子

Automotive Electronics

* 电子玩具

electronic toy

* 电子钟表

electronic clock

* 家电、数码、通信

Home appliances, digital, communication

* 照明灯饰

Lighting decoration

* 交通指示

Traffic instructions

* 医疗美容仪器

Medical beauty instruments

* 电子教学设备

Electronic teaching equipment

* 城市亮化

Urban lighting





二、外观与尺寸

Appearance and size

元器件引脚定义及元器件封装外形尺寸图

Definition of Component Pin and Outline Dimensional Drawing of Component Packaging

元器件引脚定义图

Component Pin Definition Diagram



商标同产品型号一致，标示清晰，无断符、漏眼印、残留现象

The trademark is consistent with the product model, with clear labeling and no breaks or omissions Eye print and residual phenomenon

引脚 无氧化、发黑、露铜、粘污现象

There is no oxidation, blackening, exposed copper, or sticking phenomenon on the pins

镀层厚度 引脚镀银 0.4-0.45 μm, 引脚镀锡 1-10 μm

Plating thickness: silver plated pins 0.4-0.45 μm, tin plated pins 1-10 μm

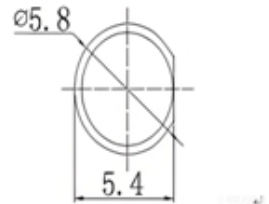
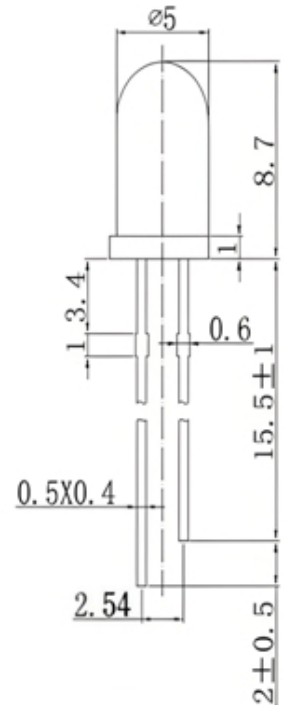

备注 (Note)

1. 标注尺寸单位为毫米

Dimensions are in millimeters.

2. 除特别标注外，所有尺寸允许公差 ± 0.50mm .

Tolerances unless mentioned are ± 0.50mm.



三、电性参数 Electrical parameters

1、最大绝对标称值（环境温度=25° C）

Maximum absolute nominal value (Environmental temperature=25 ° C)

参数 parameter	缩写 abbreviation	标称值 Nominal value	单位 unit	条件 condition
正向电流 forward current	I_F	20	mA	$I_F=20\text{mA}$
正向峰值电流 *1 Forward peak current * 1	I_{FP}		mA	$I_F=20\text{mA}$
反向电压 Reverse voltage	VR	5	V	$I_R \leq 5\mu\text{A}$
使用温度 Usage temperature	Topr	$-40^\circ\text{C} \sim +85$		$I_F=20\text{mA}$
储存温度 storage temperature	Tstg	$-40^\circ\text{C} \sim +100$		$I_F=20\text{mA}$

*IFP 条件：脉宽 $\leq 0.1\text{msec}$ ，周期 $\leq 1/10$

*IFP condition: Pulse width $\leq 0.1\text{msec}$, cycle $\leq 1/10$

2、光电特性参数（环境温度=25° C）

Optoelectronic characteristic parameters (ambient temperature=25 ° C)

参数 parameter	缩写 abbreviation	最小值 minimum value	典型值 Typical values	最大值 Maximum value	单位 unit	条件 condition
正向电压 forward voltage	Vf	1.2	-	1.4	V	$I_F=20\text{mA}$ $V_R=5\text{V}$
波长 wavelength	λ_d	940	940	940	nm	
发射角度 viewing angle	$2\theta_{1/2}$	-	45	-	deg	
反向电流 reverse current	IR	-	-	-	μA	
辐射强度 Launch distance		15	-	22	$\text{mW}/\text{sr}@$ 20mA	

备注 (Notes) :

电压偏差: $\pm 0.05\text{V}$ Voltage deviation: $\pm 0.05\text{V}$

波长偏差: $\pm 1\text{nm}$ Wavelength deviation: $\pm 1\text{nm}$



3、典型特性曲线

Typical characteristic curve

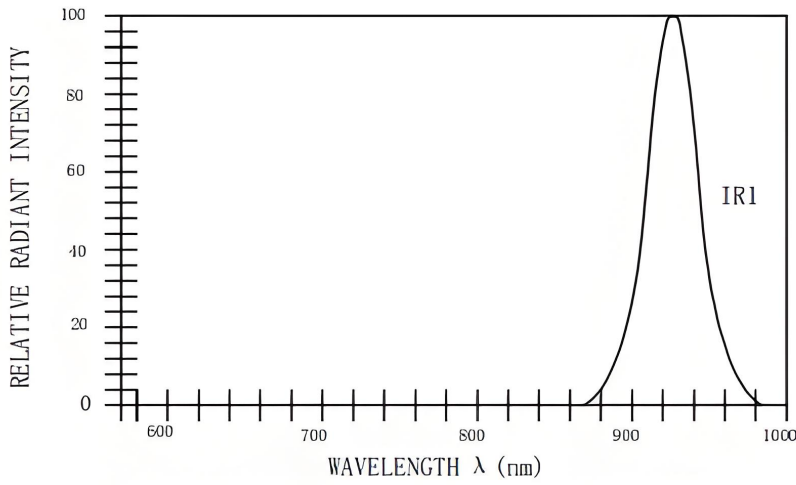

Forward Current vs. Forward Voltage

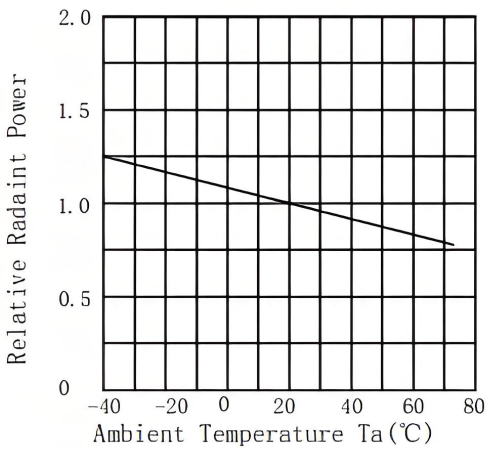

Radiant Power Vs. Ambient Temperature

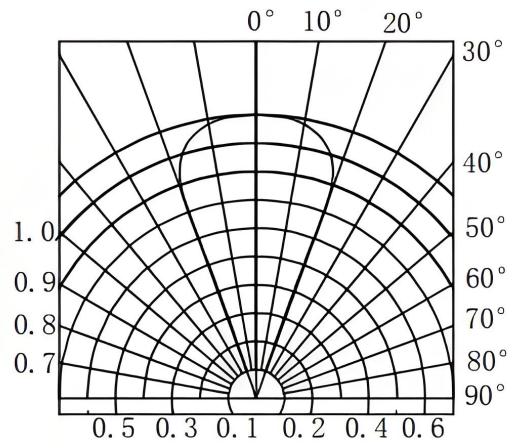

Spatial Distribution

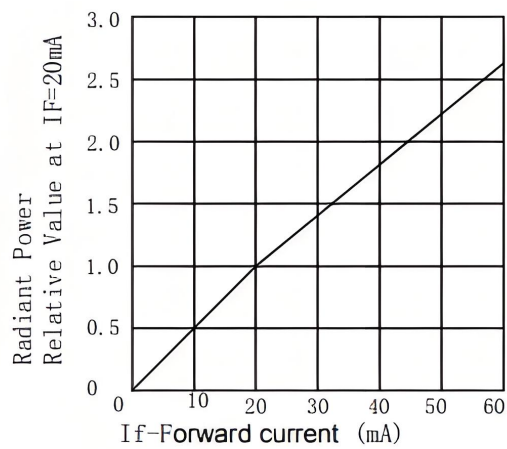
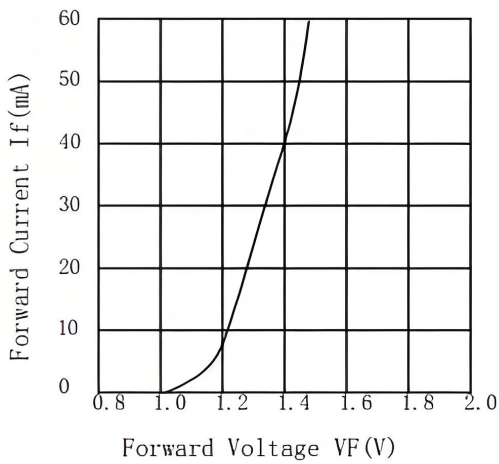



四、可靠性实验 Reliability experiment

1: 可靠性试验:

序号 Serial Number	测试项目 Test project	测试条件 Test conditions	测试持续条件 test duration	判定 judge
1	寿命测试 Life test	Ta=25°C ± 5°C, IF=20mA	1000 小时 1000 hours	合格 qualified
2	热冲击测试 Thermal Shock Test	-10°C ± 5°C ←→ +100°C ± 5°C 5min. 10sec. 5min.	100 循环 100 cycles	合格 qualified
3	冷热循环测试 heating cycle	-55°C ± 5°C ←→ +85°C ± 5°C 30min. 5min. 30min	100 循环 100 cycles	合格 qualified
4	高温高湿测试 high humidity test	Ta=85°C ± 5°C RH =85%±0.5 %RH	240 小时 240 hours	合格 qualified
5	高温贮存测试 High temperature storage test	Ta=100°C ± 5°C	1000 小时 1000 hours	合格 qualified
6	低温贮存测试 Low temperature storage test	Ta=-55°C ± 5°C	1000 小时 1000 hours	合格 qualified
7	抗焊接热度 Resistance to welding heat	Ta=260°C ± 5°C	3 秒 3 seconds	合格 qualified
8	引脚折弯 Pin bending	负荷 2.5 牛顿(0.25 千克) Load 2.5 Newtons (0.25 kg) 0° ~90° ~0°	3 回合 3 rounds	合格 qualified

出货不良率: 出货合格率为 100%, 不良率为 0ppm。

Shipment defect rate: The shipment qualification rate is 100%, and the defect rate is 0ppm



五、包装与标签说明 Packaging and labeling instructions

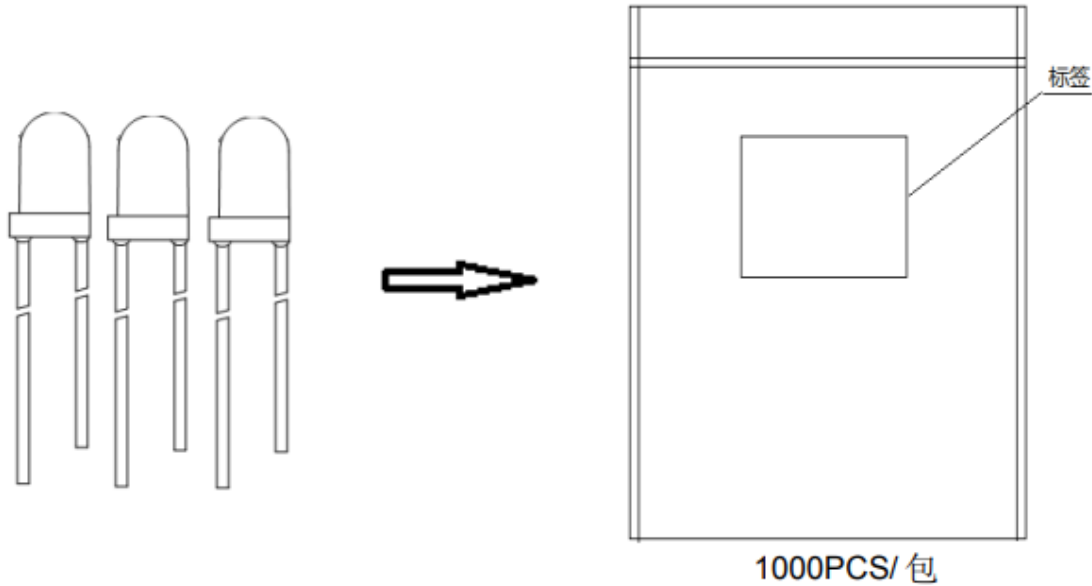

◆ 标签说明 (Label description)

LOT NO: 批次信息 (Batch Information)

PART NO: 产品型号 (PRODUCT MODEL)

BIN CODE: 产品名称 (product name)

WL: 波长范围 (wavelength range)

LV: 光强范围 (Light intensity range)

VF: 电压范围 (Voltage range)

运输要求 (Transportation requirements) :

- (1) 箱体上不易压重物 (Not easy to press heavy objects on the box)
- (2) 正面朝上 (face up)
- (3) 不易受潮 (Not easily affected by moisture)



六、焊接指导与产品命名

Welding guidance and product naming

一、可焊性 solderability

a) 波峰焊条件

Wave soldering conditions

b) 烙铁焊接温度要求：温度约 350℃，焊接时间约 2S。

Soldering temperature requirements: temperature of about 350 °C, soldering time of about 2 seconds

c) 可焊性试验条件：温度约 240~250℃，试验时间为 3S，要求试验后测试电性能正常，外观无不良。

Solderability test conditions: temperature of approximately 240~250 °C, test time of 3 seconds, requiring normal electrical performance and no defects in appearance after the test.

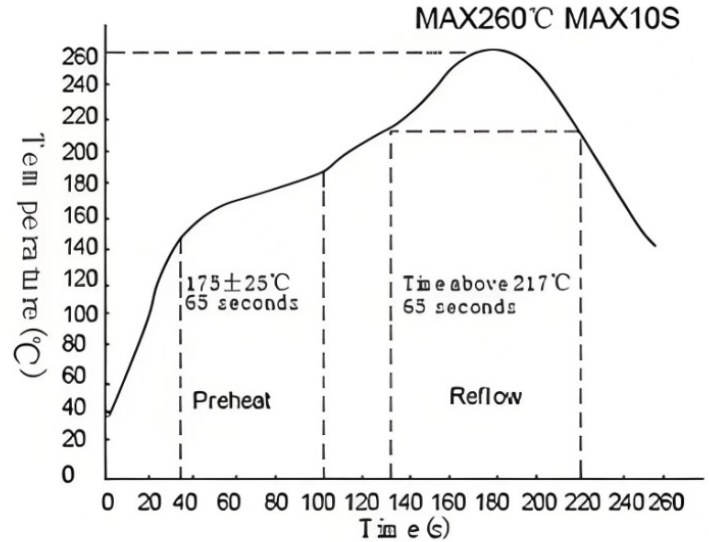

元器件型号的命名规则和本体标识：

Naming rules and body identification for component models

产品型号 (P/N) 命名规则说明例如下：

The naming rules for product models (P/N) are as follows

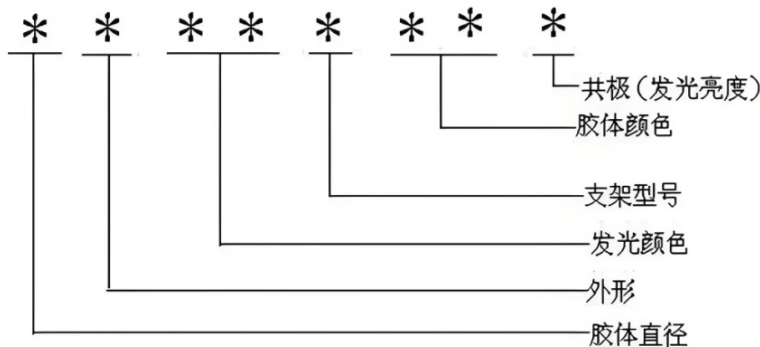



七、使用注意事项 Precautions for use

1、清洗 (clean)

当用化学品清洗胶体时必须特别小心，因为有些化学品对胶体表面有损伤并引起褪色，如三氯乙烯、丙酮等。可用乙醇擦拭、浸渍，时间在常温下不超过 3 分钟。

Special care must be taken when cleaning colloids with chemicals, as some chemicals can damage the surface of colloids and cause fading, such as trichloroethylene, acetone, etc. Can be wiped and soaked with ethanol for no more than 3 minutes at room temperature.

2、引脚装配 (Pin assembly)

- (1) 必需离胶体 2 毫米才能折弯支架。

It is necessary to be 2 millimeters away from the gel to bend the bracket.

- (2) 支架成形必须用夹具或由专业人员来完成。

The formation of the bracket must be completed using fixtures or by professionals

- (3) 支架成形必须在焊接前完成。

The bracket forming must be completed before welding

- (4) 支架成形需保证引脚和间距与线路板上一致。

The bracket forming needs to ensure that the pins and spacing are consistent with those on the circuit board

- (5) 焊接必须在正常温度下进行，当 LED 正常焊接到 PCB 板上后，应尽量避免在 LED 引脚处施加机械压力。

Welding must be carried out at normal temperature. When the LED is soldered to the PCB board normally, mechanical pressure should be avoided as much as possible at the LED pins

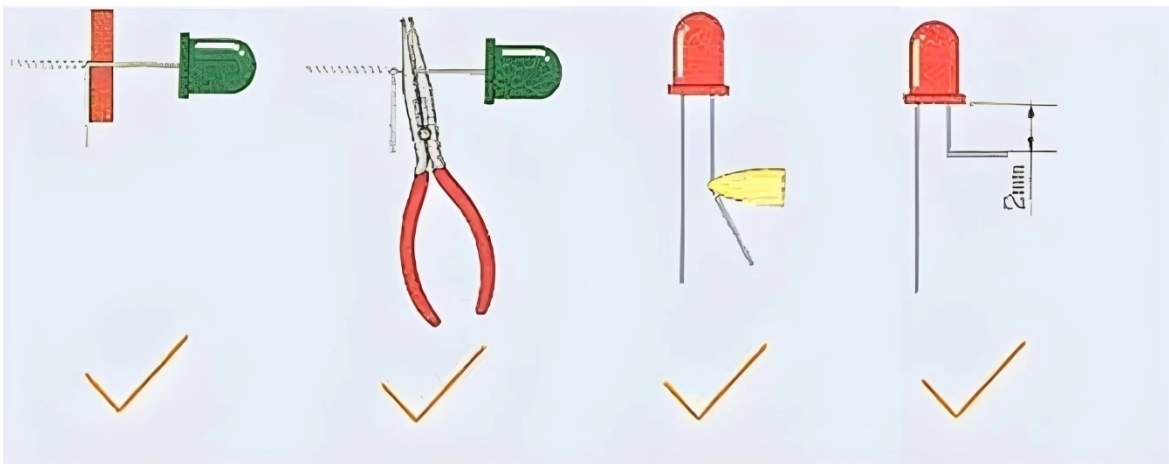



3、静电防护 (electrostatic protection) :

静电和电流的急剧升高将会对 LED 产生损害, 桂光系列产品使用时请使用防静电装置, 如防护带和手套。

The sharp increase in static electricity and current will cause damage to LEDs. Please use anti-static devices such as protective belts and gloves when using guiguang series products.

注意: 使用时人体放电模式 HBM<1000V; 机器放电模式<100V。

Attention: When using, the human body discharge mode HBM should be less than 1000V; Machine discharge mode<100V.

4、LED 是电流驱动元件, 电压的细微变化会产生较大的电流波动, 导致元件遭到破坏。客户应使用电阻串联作限流保护

LED is a current driven component, and slight changes in voltage can cause significant current fluctuations, leading to damage to the component. Customers should use resistors in series for current limiting protection

5、过高的环境温度会影响 LED 的亮度以及其他性能, 所以为能使 LED 有较

Excessive environmental temperature can affect the brightness and other performance of LED, so in order to make LED more efficient

6、为了确保多颗 LED 并联使用时光色一致, 建议每条支路使用单独阻, 如下图模式 A 所示;

如采用下图模式 B 所示电路, LED 光色可能因每一颗 LED 不同的伏安特性而造成光色差异。

To ensure color consistency when multiple LEDs are used in parallel, it is recommended to use separate resistors for each branch, as shown in Mode A in the following figure;

If the circuit shown in pattern B is used, the color of LED may vary due to the different volt ampere characteristics of each LED.

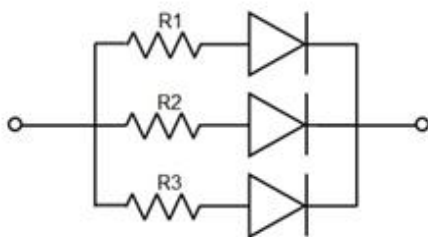

电路模式 A

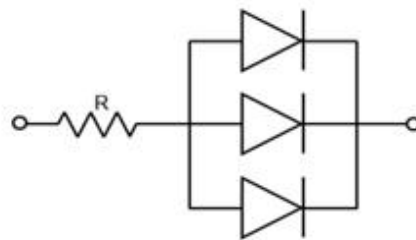

电路模式 B

7、高亮度 LED 产品点亮时可能会对人眼造成伤害, 应避免从正上方直视

High brightness LED products may cause harm to the human eye when lit up, and should be avoided from looking directly at them from above



8、本规格所描述的 LED 定义应用在普通的电子设备范围（例如办公设备、通讯设备等等）。如果有更为严苛的信赖度要求，特别是当元件失效或故障时可能会直接危害到生命和健康时（如航天、运输、交通、医疗器械、安全保护等等），请事先知会敝司业务人员

The LED definition described in this specification is applicable to ordinary electronic devices (such as office equipment, communication equipment, etc.). If there are stricter reliability requirements, especially when component failure or malfunction may directly endanger life and health (such as aerospace, transportation, traffic, medical equipment, safety protection, etc.), please inform our business personnel in advance

9、出于持续改善的目的，产品外观和参数规格可能会在没有预先通知的情况下作改良性变化

For the purpose of continuous improvement, the appearance and specifications of the product may undergo changes without prior notice

10、声明 The statement

选购桂光光电生产之产品即享有保质期内标准售后服务，详情请洽询我司相关销售人员，桂光光电有限公司保留最终决定处理方式的权力，相关质保服务仅限于桂光光电产品本体，恕不对客户端产品/系统等负担衍生性的责任(含直接及间接)。客户如未对产品进行规格和功能性验证及索取对应产品承认书（规格书）资料进行签署确认直接下单则视为默认此服务条款。

客户进货检验 IQC(Incoming Quality Control)、最终检验 FQC(Final Quality Control)、系统质量检验 SQC(System Quality Control)等不同阶段如有发现产品品质异常，请尽速与我司相关销售人员联系。经桂光光电技术人员分析结果，如可确认归责为我公司产品瑕疵的，客户可与我司相关销售人员协商退货/换货/退款方式择一处理。合作中惟本条款与其它合约协议不一致的均以此条款为准。

Guiguang photoelectric production of choose and buy products that have standard warranty period after-sales service, for details, please inquire our relevant sales staff, Guiguang photoelectric co., LTD. Reserves the right to final decision approach is limited to ontology Guiguang photoelectric products, quality services related to tell wrong client product/system such as the responsibility of the burden of yan malleable (including direct and indirect). If the customer places an order directly without verifying the specifications and functionality of the product and signing the corresponding product acknowledgement document (specification), it will be deemed as a default of this service term.

Incoming Quality Control (IQC), Final Quality Control (FQC), System Quality Control (SQC) and other different stages of customer Incoming Quality Control (IQC), Incoming Quality Control (FQC), System Quality Control (SQC) Please contact our sales staff as soon as possible. According to the analysis result of Guiguang photoelectric technical personnel, if it can be confirmed that the fault is attributed to our company's product defects, the customer can negotiate with our company's relevant sales staff to choose a way to deal with the return/replacement/refund. In cooperation, this clause shall prevail if there is any inconsistency between this clause and other contractual agreements.

the luminous color. Heat dissipation should be fully considered in the design