

## 1. 产品特点 Product features

- 峰值击穿电压 600V Peak breakdown voltage 600V
- 输入与输出间高隔离电压(Viso=5000 V rms)  
High isolation voltage between inputs and output (Viso=5000 V rms)
- 零电压交叉 Zero voltage crossing
- 符合欧盟REACH法规 Compliance with EU REACH
- 无Pb且符合ROHS标准 Pb free and RoHS compliant

## 2. 产品描述 Product Description

- MOC306X系列由一个砷化镓红外发光二极管和一个单晶硅芯片的零交叉光电双向晶闸管组成的可控硅光电耦合器

The MOC306X of devices each consist of a GaAs infrared emitting diode optically coupled to a monolithic silicon zero voltage crossing photo triac.

- 它被设计用于与逻辑系统到110-380伏线路的设计接口, 如固态继电器、工业控制、电机、螺线管和消费电器  
It is designed for use with a discrete power triac in the interface of logic systems to equipment powered from 110 to 380 VAC lines, such as solid-state relays, industrial controls, motors, solenoids and consumer appliances.

## 3. 产品应用 Product Applications

- 灯光控制、电磁阀控制 Light controls, Solenoid/valve controls
- 静态电源开关、电磁接触器 Static power switch, E.M. contactors
- 交流电机驱动器、交流电动机启动器 AC motor drivers, AC Motor starters
- 温度控制 Temperature controls

## 4. 功能图 Functional Diagram

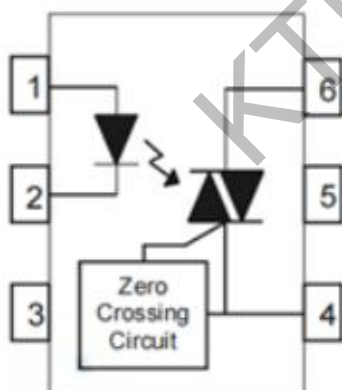

### 引脚配置 Pin Configuration

1. 阳极 Anode
2. 阴极 Cathode
3. 无连线 No Connection
4. 终端 Terminal
5. 基板(不接线) Substrate (do not connect)
6. 终端 Terminal

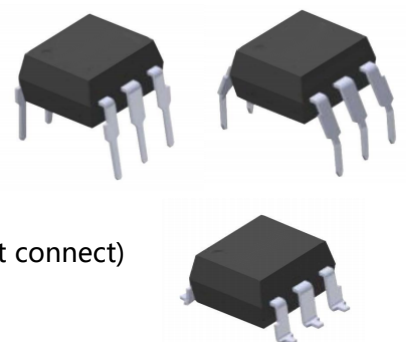

## 5. 光电特性 Electrical-Optical characteristics

• 最大限度额定值(温度=25°C) Absolute Maximum Ratings(Ta=25°C)

参数 Parameter		符号 Symbol	额定值 Rated Value	单位 Unit
输入 Input	正向电流 Forward current	$I_F$	60	mA
	反向电压 Reverse voltage	$V_R$	6	V
	功耗 Power dissipation	$P_D$	100	mW
	降额系数(高于Ta=85°C) Derating factor (above Ta = 85°C)		3.8	mW/°C
输出 Output	断态输出端电压 Off-state Output Terminal Voltage	$V_{DRM}$	600	V
	峰值重复浪涌电流 Peak Repetitive Surge Current (pw=1ms,120pps)	$I_{TSM}$	1	A
	导通有效值电流 On-State RMS Current	$I_{T(RMS)}$	100	mA
	输出功率 Output Power dissipation	$P_C$	300	mW
	降额系数 (高于Ta=85°C) Derating factor (above Ta = 85°C)		7.6	mW/°C
	总消耗功率 Total Consume Power		$P_{TOT}$	330
隔离电压 (1*) Isolation Voltage		$V_{iso}$	5000	Vrms
工作温度 Operating temperature		$T_{OPR}$	-55 to +100	°C
储存温度 Storage temperature		$T_{STG}$	-55 to +125	°C
焊接温度 (2*) Soldering temperature		$T_{SOL}$	260	°C

附注 (Notes):

1\* 交流电源1分钟内, 相对湿度在40~60%RH环境下, 隔离电压测试时, 1&2&3脚短接在一起, 4&5&6脚短接在一起  
AC for 1 minute, R.H.= 40 ~ 60% R.H. In this test, pins 1, 2&3 are shorted together, and pins 4, 5 & 6 are shorted together.

2\* 焊接时间为10秒 Soldering time is 10 seconds

## 6. 电气特性(Ta=25°C,除非另有规定)

### Electrical Characteristics(Ta=25°C unless specified otherwise)

参数 Parameter		符号 Symbol	最小值 Min.	规格值 Typ.	最大值 Max.	单位 Unit	条件 Condition
输入 In put	正向电压 Forward voltage	$V_F$	-	-	1.5	V	$I_F=30\text{mA}$
	反向电流 Reverse current	$I_R$	-	-	10	$\mu\text{A}$	$V_R=6\text{V}$
输出 Out put	断态峰值电流 Peak Blocking Current	$I_{\text{DRM1}}$	-	-	500	nA	$V_{\text{DRM}} = \text{Rated } V_{\text{DRM}}$ $I_F = 0 \text{ mA } 2^*$
	峰值导通电压 Peak On-state Voltage	$V_{\text{TM}}$	-	-	3	V	$I_{\text{TM}}=100 \text{ mA peak,}$ $I_F=\text{Rated } I_{\text{FT}}$
	断态电压临界 上升率 Critical Rate of Rise off-state Voltage	dv/dt	1000	-	-	V/ $\mu\text{s}$	$V_{\text{PEAK}} = \text{Rated } V_{\text{DRM}}, I_F=0\text{mA}$ (Fig. 10) 3*
	抑制电压(MT1-MT2电压,高于该电压器件将不触发) Inhibit Voltage (MT1-MT2 voltage above which device will not trigger)	$V_{\text{INH}}$	-	-	20	V	$I_F = \text{Rated } I_{\text{FT}}$
抑制状态下的漏电 Leakage in Inhibited State	$I_{\text{DRM2}}$	-	-	500	$\mu\text{A}$	$I_F = \text{Rated } I_{\text{FT}}$ $V_{\text{DRM}} = \text{Rated } V_{\text{DRM, off state}}$	

• 附注(Notes):

1\*. Ta=25°C时的规格值 Typical values at Ta = 25°C

2\*. 测试电压必须在dv/dt额定值范围内 Test voltage must be applied within dv/dt rating

3\*. 这是静态的dv/dt, 转换直流dv/dt只有负载驱动晶闸管的函数

This is static dv/dt, Commutating dv/dt is a function of the load-driving thyristor(s) only

• 传输特性 (Ta=25°C, 除非另有规定)

Transfer Characteristics (Ta=25°C unless specified otherwise)

参数 Parameter		符号 Symbol	最小值 Min.	规格值 Typ.	最大值 Max.	单位 Unit	条件 Condition
LED触发电流 LED Trigger Current	MOC3061	I <sub>FT</sub>	-	-	15	mA	主端子电压=3V Main terminal Voltage=3V 4*
	MOC3062		-	-	10		
	MOC3063		-	-	5		
保持电流 Holding Current		I <sub>H</sub>	-	280	-	uA	

附注(Notes):

4\*. 所有设备都保证在小于或等于最大IFT的IF值触发. 因此, 建议工作IF介于最大IFT(MOC3061的15mA, 10mA 适用于MOC3062, 5mA适合MOC3063)和绝对最大值(60mA)

All devices are guaranteed to trigger at an IF value less than or equal to max IFT. Therefore, recommended operating IF lies between max IFT (15 mA for MOC3061, 10 mA for MOC3062, 5 mA for MOC3063) and absolute maximum IF (60 mA)

## 7. 可靠性试验 Reliability Test

序号 NO.	试验项目 Test Items	参考标准 Reference	试验条件 Test conditions	试验过程 Test process	试验数 Qty.(pcs)	允收水准 LTPD
1	温度循环 TC	JESD22-A104C	H:125±5°C 15min ∫ 5min L:-55±5°C 15min	300cycle	45	0/45
2	高温操作寿命 HTOL	JESD22-A108C	HTOL@110±5°C I <sub>F</sub> =15mA I <sub>C</sub> =AC 20mA	168、500、 1000hrs	45	0/45
3	高温反向偏压 HTRB	JESD22-A108C	HTRB@100±5°C V <sub>ce</sub> =640V	168、500、 1000hrs	45	0/45
4	温湿度反向偏压寿命试验 H3TRB	JESD22-A101-B	H3TRB@ 85±5°C、 85±5%RH V <sub>ce</sub> =100V	168、500、 1000hrs	45	0/45
5	压力锅 Autoclave	JESD22-A102-C	T <sub>a</sub> =121±5°C, 100%RH, 2atm	96hrs	45	0/45
6	高温储存 HTS	JESD22-A103C	HTS@125±5°C	168、500、 1000hrs	45	0/45
7	低温储存 LTS	JESD22-A119	LTS@-55±5°C	168、500、 1000hrs	45	0/45
8	耐锡热试验 RSH	JESD22-B106C	RSH@260±5°C	10sec*3times	45	0/45
9	可焊性 SD	JESD22-B102D	Pb-free@ 245±5°C	3sec*1times	22	0/22
备注 Remarks	以上试验项目如与客户试验要求存在差异或者特殊客户特殊要求的,可根据实际情况按照客户的要求进行试作,客户未要求依我司试验标准试作,不同产品使用不同电流进行测试 All the tests should be performed according to customers' actual requirements, while difference of test standard or special requirements exist. Otherwise, all the tests are performed according to the standard listed above. Different current is applied to the tests of different product models					

## 8. 特性曲线 Characteristic Curves

图1. 正向电流与正向电压的关系  
Forward Current VS Forward Voltage



图2. 导通特性  
On-State Characteristics



图3. 保持电流 vs 环境温度的关系  
Holding Current vs Ambient Temperature

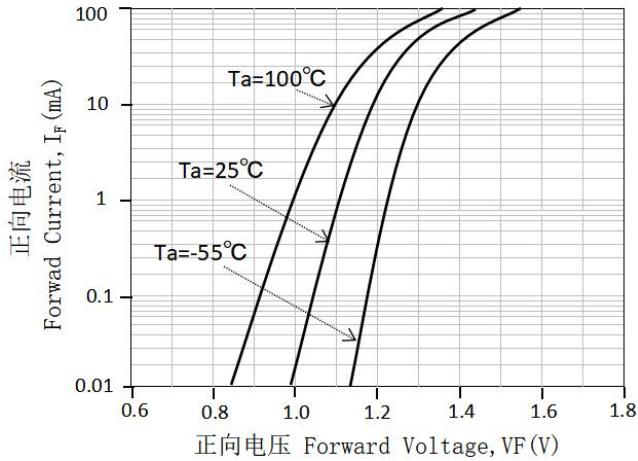

图4. 触发所需的LED电流 vs LED脉冲宽度的关系  
LED Current Required to Trigger vs LED Pulse Width

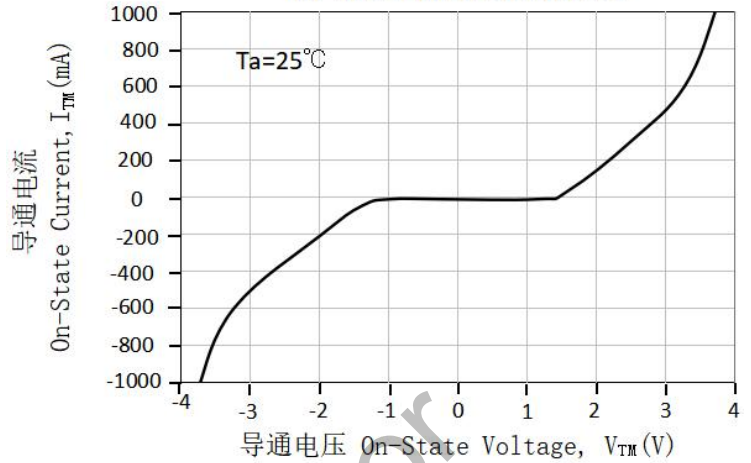

图5. 漏电流 vs 环境温度的关系  
Leakage Current VS Ambient Temperature

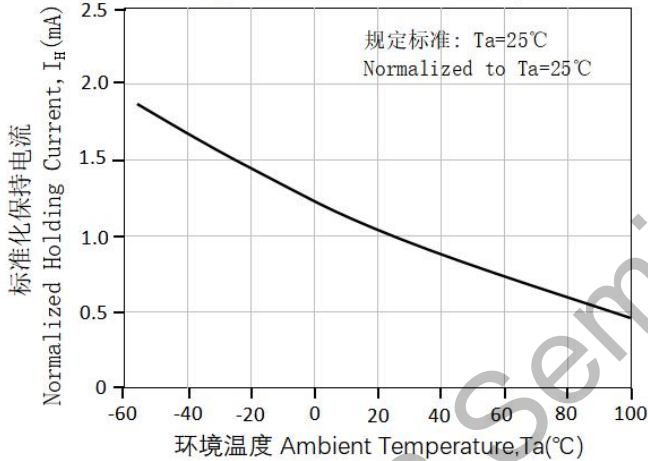

图6. LED触发电流 vs 环境温度的关系  
LDE Trigger Current vs Ambient Temperature

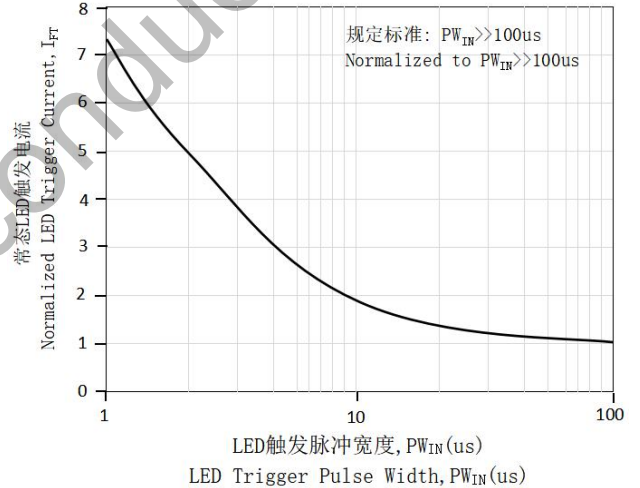

图7. 关闭状态输出端电压vs环境温度的关系

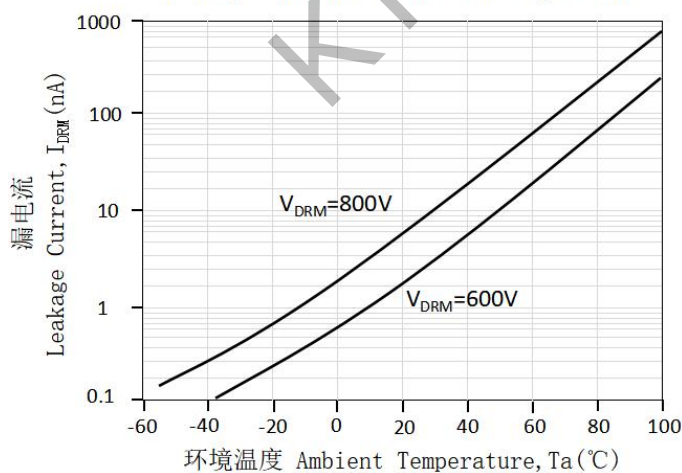

图8. 抑制状态下的漏电 vs 环境温度的关系  
Leakage in Inhibit State vs Ambient Temperature

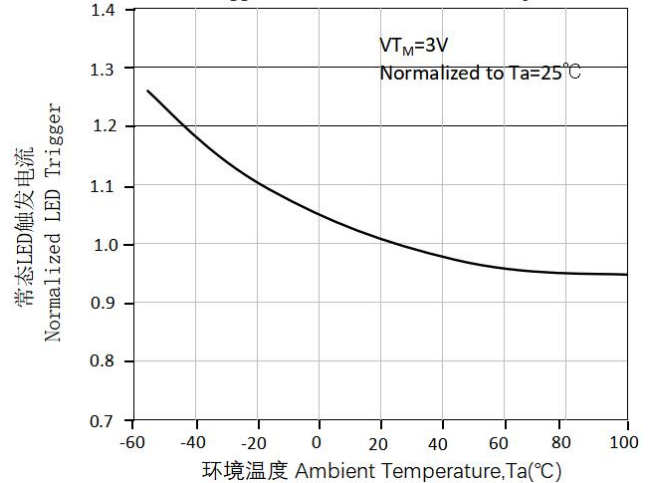

图9. 抑制电压与环境温度  
Inhibit Voltage vs Ambient Temperature

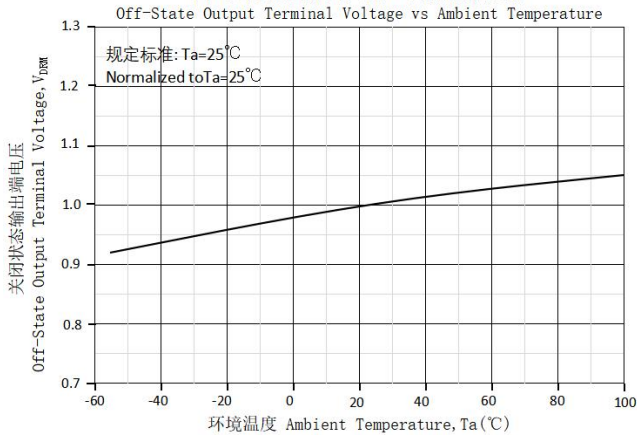

KTP Semiconductor

图10. 静态dv/dt测试电流和波形  
Static dv/dt Test Circuit & Waveform

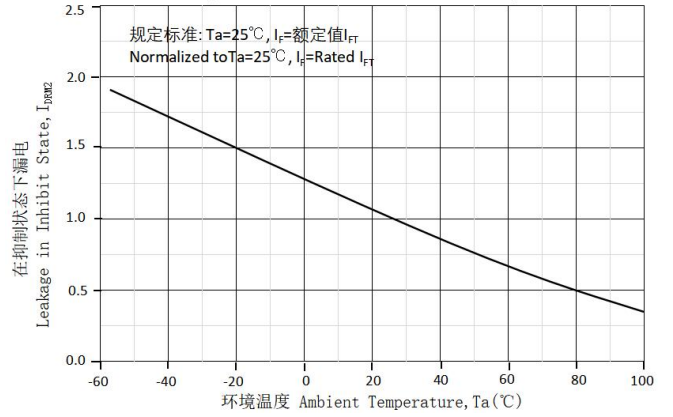
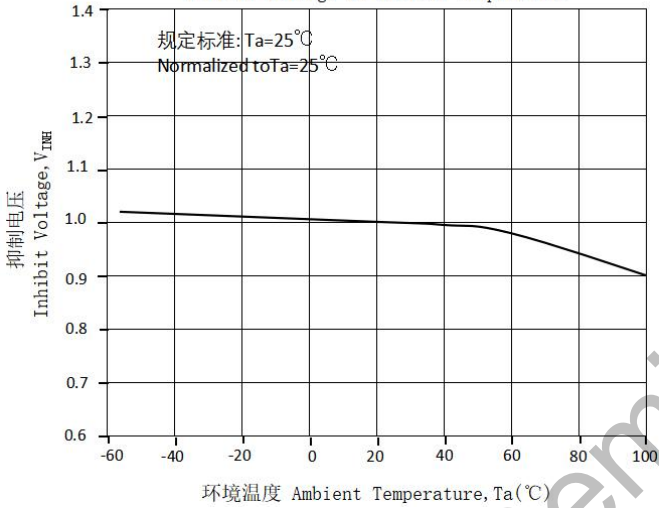
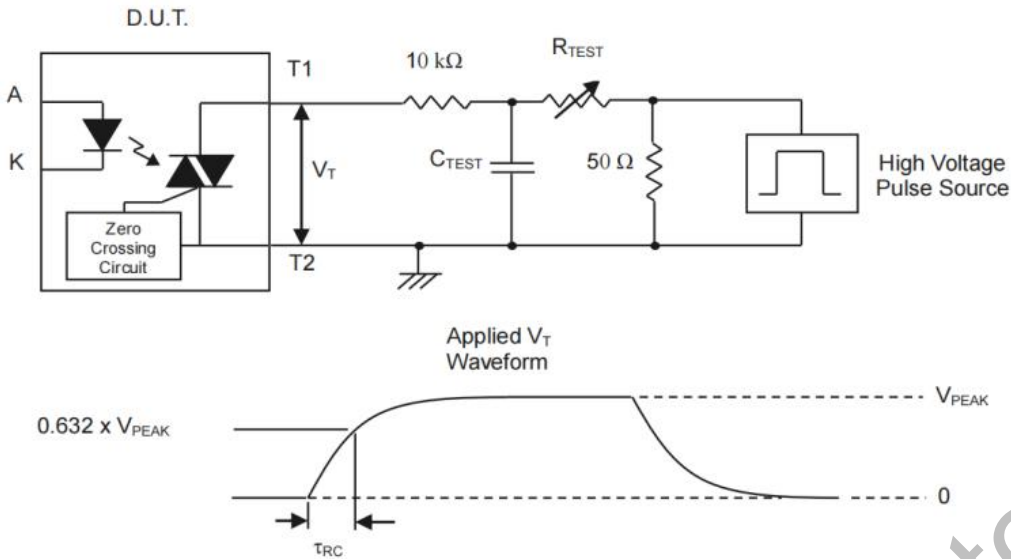

### 测量方法 Measurement Method

高压脉冲设置为所需的 $V_{PEAK}$ 值, 并通过上述RC电路应用于D.U.T输出值, 不应用LED电流, 使用X100范围探头监视波形 $V_T$ , 通过改变 $R_{TEST}$ ,  $dv/dt$ (斜率)增加, 直到DU被观察到触发(波形崩溃)。  $dv/dt$ 随后下降, 直到D.U.T.停止触发, 此时记录 $\tau_{RC}$ , 计算 $dv/dt=0.632 \cdot V_{PEAK} / \tau_{RC}$

The high voltage pulse is set to the required  $V_{PEAK}$  value and applied to the D.U.T. output side through the RC circuit above. LED current is not applied. The waveform  $V_T$  is monitored using a x100 scope probe. By varying  $R_{TEST}$ , the  $dv/dt$  (slope) is increased, until the D.U.T. is observed to trigger (waveform collapses). The  $dv/dt$  is then decreased until the D.U.T. stops triggering. At this point,  $\tau_{RC}$  is recorded and the  $dv/dt$  calculated.  $dv/dt=0.632 \cdot V_{PEAK} / \tau_{RC}$

例如, MOC306X系列的 $V_{PEAK}=600V$ ,  $dv/dt$ 值的计算公式如下:

For example,  $V_{PEAK} = 600V$  for MOC306X series. The  $dv/dt$  value is calculated as follows:

$$dv/dt = 0.632 \cdot 600 / \tau_{RC}$$

## 9. 订单信息 Order Information

- 材料编号 Part Number

### MOC306X-Y-Z-AW

#### 附注(Notes):

- X = 零件编号(1、2 或 3)  
Part No. (1, 2 or 3)
- Y = 引脚形式选项(S、S1、M 或 无)  
Lead form option (S, S1, M or none)
- Z = 料带和卷轴选项(TA、TB 或 无)  
Tape and reel option (TA, TB or none)
- AW = 表示内部识别码(有或无)  
Internal Identification code(yes or none)

选项 Option	描述 Description	包装数量 Packing quantity
无 None	标准DIP-6 Standard DIP-6	每管65pcs 65 units per tube
M	宽引脚弯曲(0.4英寸间距) Wide lead bend (0.4 inch spacing)	每管65pcs 65 units per tube
S (TA)	表面贴装引线形式+TA载带和卷轴选项 Surface mount lead form + TA tape & reel option	每卷1000pcs 1000 units per tube
S (TB)	表面贴装引线形式+TB载带和卷轴选项 Surface mount lead form + TB tape & reel option	每卷1000pcs 1000 units per tube
S1 (TA)	表面贴装引线形式(低剖面)+TA载带和卷轴选项 Surface mount lead form (low profile) + TA tape & reel option	每卷1000pcs 1000 units per reel
S1 (TB)	表面贴装引线形式(低剖面)+TB载带和卷轴选项 Surface mount lead form (low profile) + TB tape & reel option	每卷1000pcs 1000 units per reel

## 10. 封装尺寸(单位:毫米) Package Drawing(Unit:mm)

- 标准DIP型号 Standard DIP Type

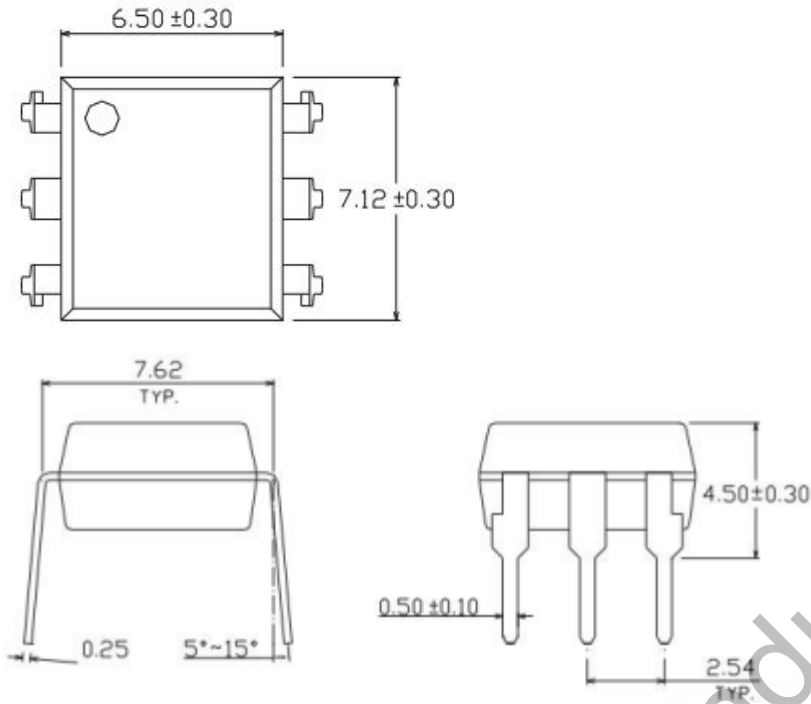

- 选择M型号 Option M Type

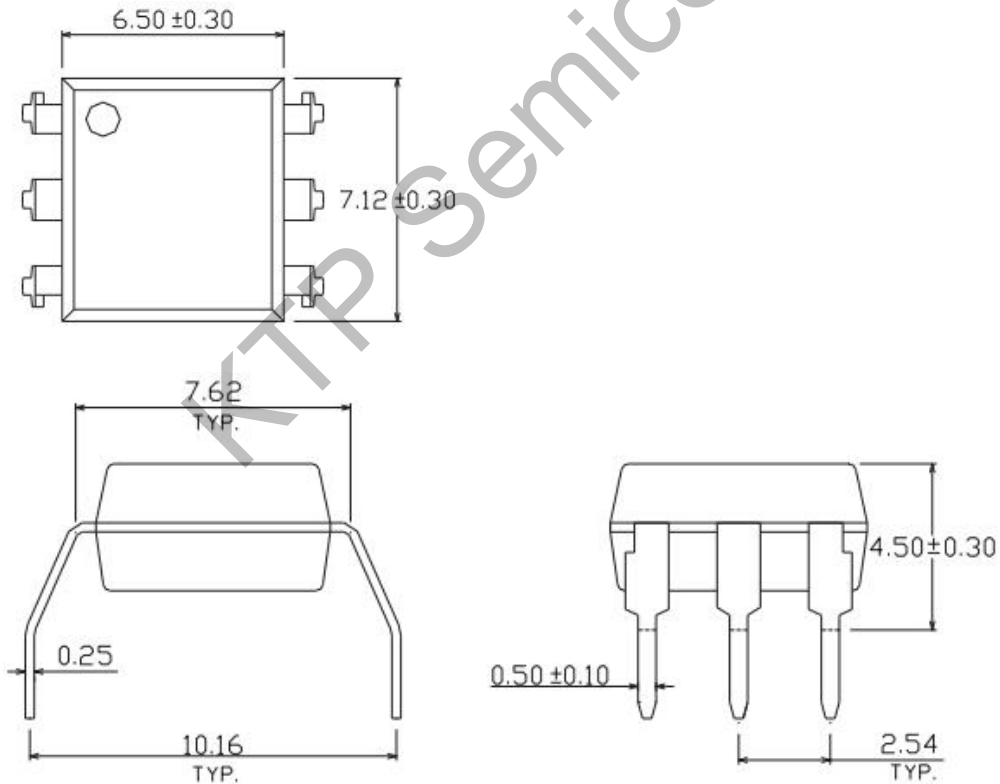

• 选择S型号 Option S Type

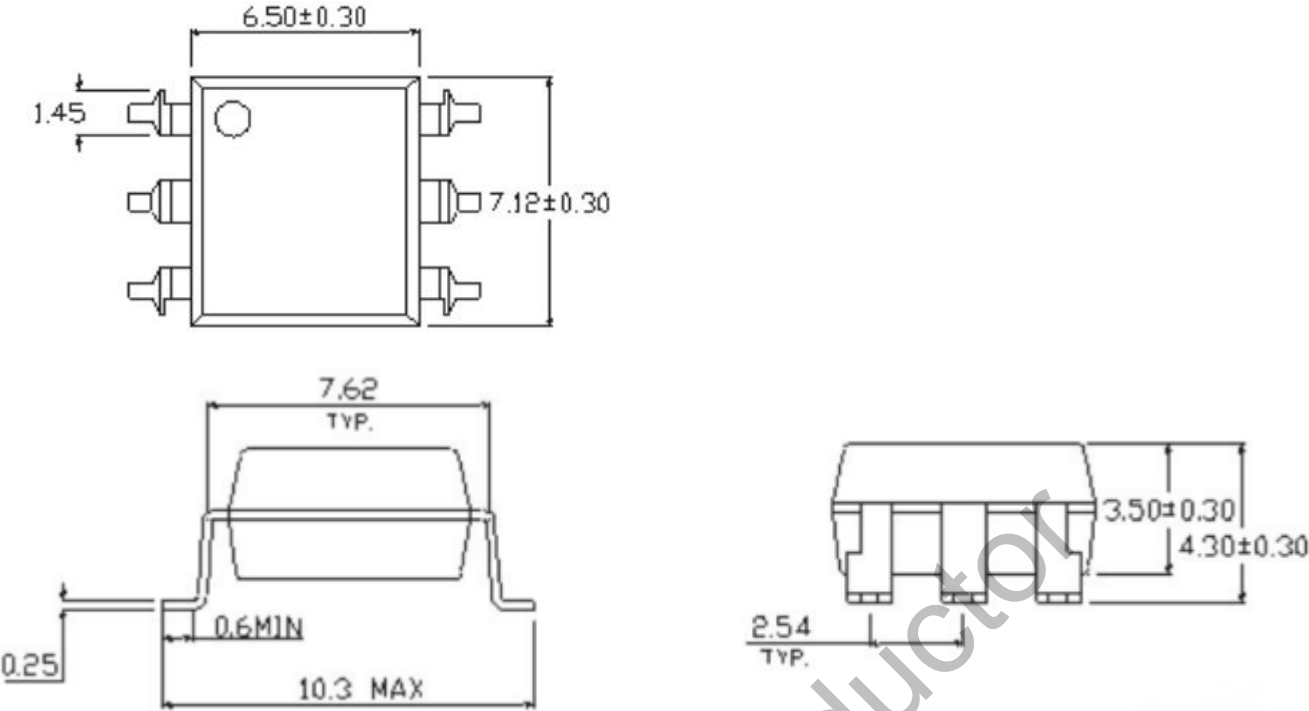

• 选择S1型号 Option S1 Type

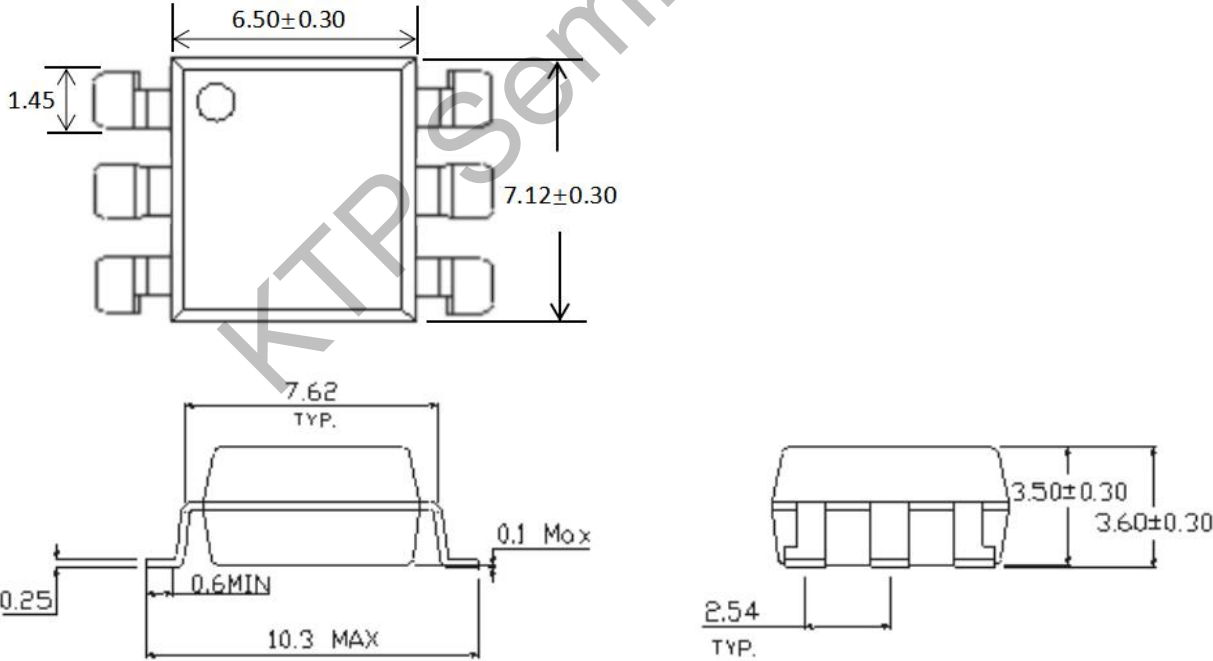

- 表面贴片类型PIN脚焊盘布局 Surface patch type PIN foot pad layout

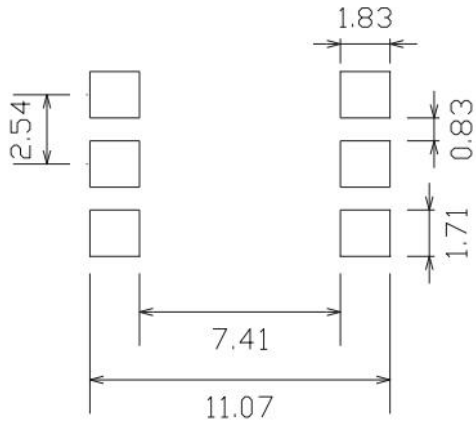

附注(Notes):

- 推荐焊盘尺寸仅供参考 Suggested pad dimension is just for reference only
- 请根据个人需要修改焊盘尺寸 Please modify the pad dimension based on individual need

KTP Semiconductor

## 11. 料带和卷轴包装规格 Tape & Reel Packing Specifications

• 选择TA Option TA

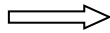
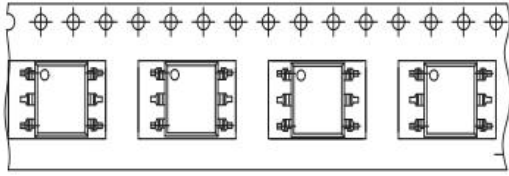

卷轴进给方向 Direction of feed from reel

• 选择TB Option TB

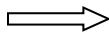
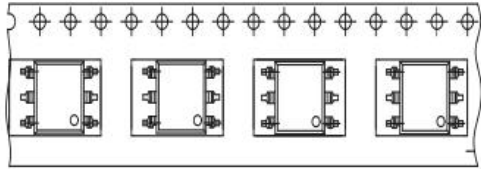

卷轴进给方向 Direction of feed from reel

### 料带尺寸 Material belt size

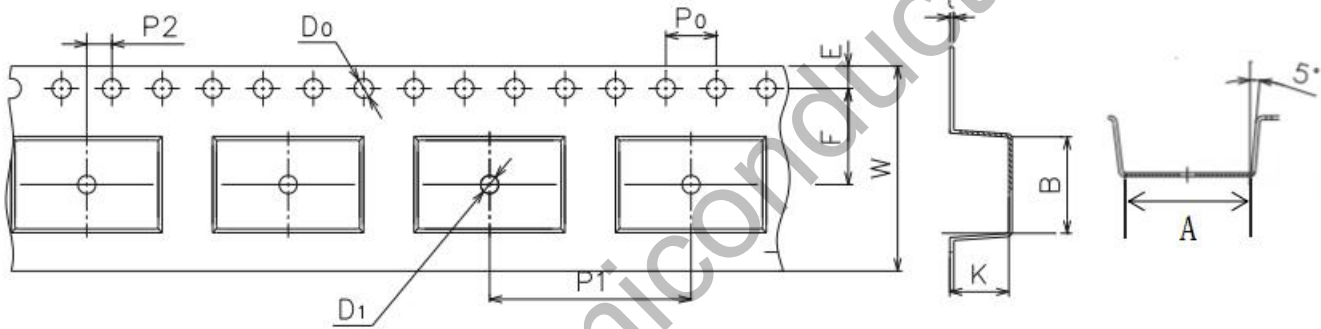

尺寸编号 Dimension No.	A	B	D0	D1	E	F
尺寸(mm) Dimension(mm)	10.8±0.1	7.55±0.1	1.5±0.1	1.5±0.1	1.75±0.1	7.5±0.1
尺寸编号 Dimension No.	P0	P1	P2	t	W	K
尺寸(mm) Dimension(mm)	4.0±0.15	16.0±0.1	2.0±0.1	0.35±0.03	16.0±0.2	4.5±0.1

## 12. 焊接温度曲线 Temperature Profile Of Soldering

### • 回流焊焊接条件 Reflow soldering Soldering Condition

建议在下面所示的温度和时间分布条件下, 进行一次回流焊作业, 不得超过三次

One time soldering reflow is recommended within the condition of temperature and time profile shown below. Do not solder more than three times.

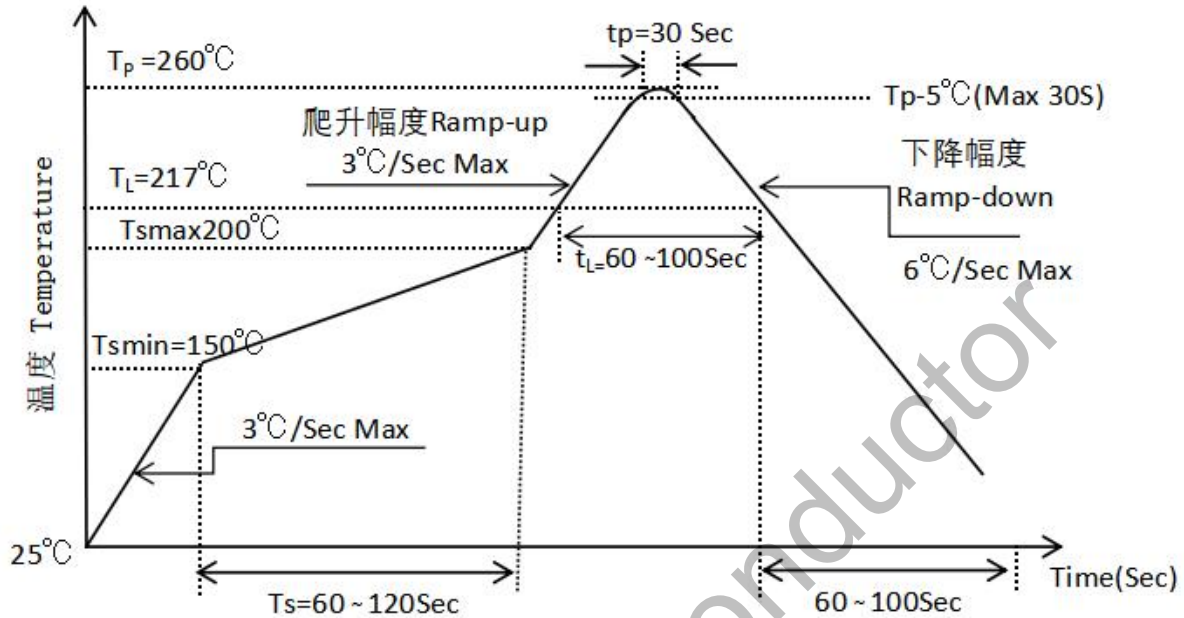

项目 Item	符号 Symbol	最小值 Min.	最大值 Max.	单位 Unit
预热温度 Preheat Temperature	$T_s$	150	200	°C
预热时间 Preheat Time	$t_s$	60	120	s
升温速率 Ramp-Up Rate ( $T_L$ to $T_P$ )	-	-	3	°C/s
液相线温度 Liquidus Temperature	$T_L$	217		°C
高于液相线温度( $T_L$ ) 的时间 Time above Liquidus Temperature $T_L$	$t_L$	60	100	s
峰值温度 Peak Temperature	$T_P$	-	260	°C
$T_c$ 在( $T_P-5$ )和 $T_P$ 之间的时间 Time During Which $T_c$ Is Between ( $T_P-5$ ) and $T_P$	$t_p$	-	30	s
降温速率 Ramp-down Rate( $T_P$ to $T_L$ )	-	-	6	°C/s

## • 波峰焊温度曲线 Wave Soldering

温度条件下, 建议一次焊接

One time soldering is recommended within the condition of temperature

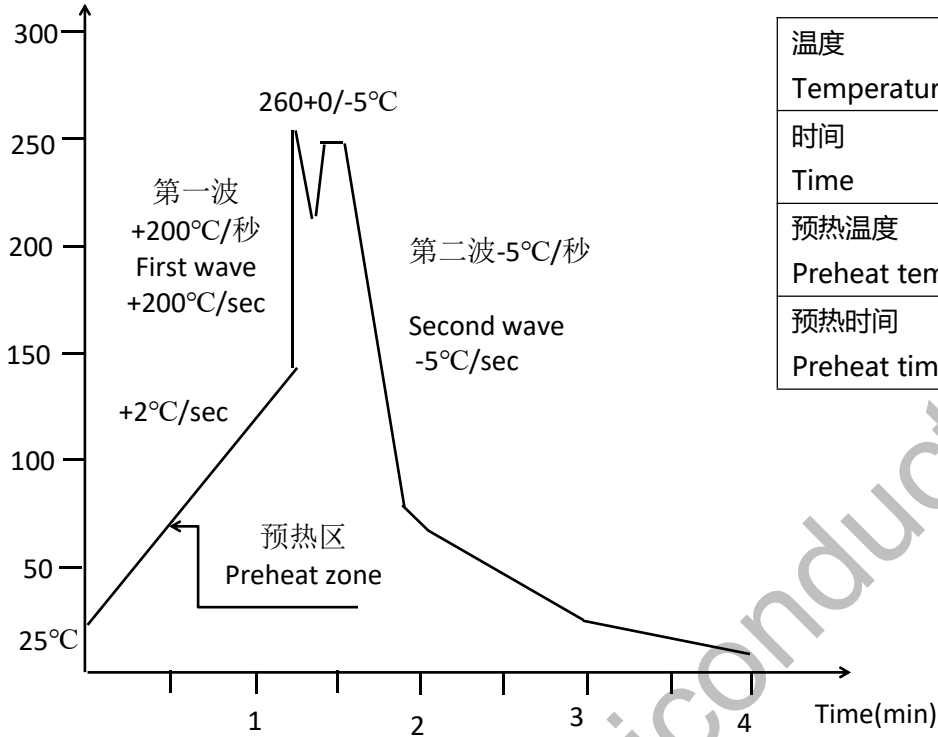

温度	260°C+0/-5°C
Temperature	260°C+0/-5°C
时间	10秒
Time	10S
预热温度	25至140°C
Preheat temperature	25 to 140°C
预热时间	30至80秒
Preheat time	30 to 80 S