

Features:

- Wide supply voltage range from 3V to 15V
- Fully static operation
- 5V, 10V, and 15V parametric ratings
- Standardized symmetrical output characteristics
- Inputs and outputs are protected against electrostatic effects
- Specified from -40°C to +105°C
- Packaging information: DIP-14/SOP-14/TSSOP-14

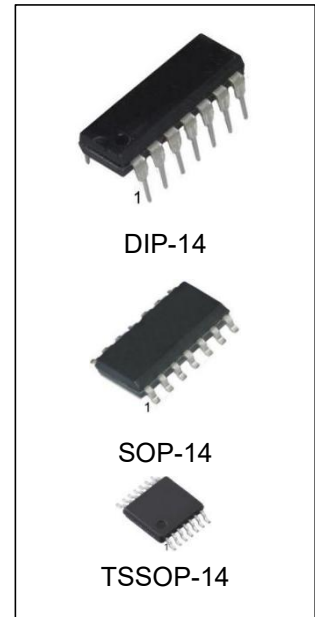

Ordering Information

DEVICE	Package Type	MARKING	Packing	Packing Qty
CD4023BE/ CD4023BN	DIP-14	CD4023B	TUBE	1000pcs/Box
CD4023BM/TR	SOP-14	CD4023B	REEL	2500pcs/Reel
CD4023BMT/TR	TSSOP-14	CD4023B	REEL	2500pcs/Reel

General Description

The CD4023B provides the positive triple 3-input NAND function. The outputs are fully buffered for highest noise immunity and pattern insensitivity of output impedance.

It operates over a recommended V_{DD} power supply range of 3V to 15V referenced to GND (usually ground). Unused inputs must be connected to V_{DD} , GND, or another input.

Block Diagram

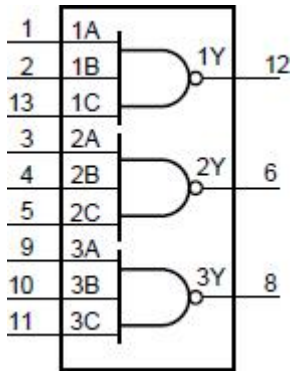

Figure 1. Functional diagram

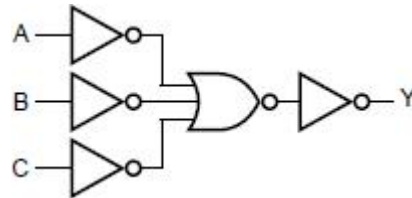
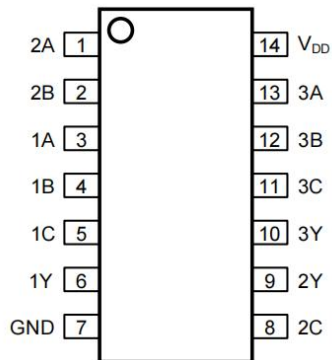

Figure 2 Logic diagram (one gate)

Pin Configurations



DIP-14,SOP-14,TSSOP-14

Pin Description

Pin No.	Pin Name	Description
1	2A	data input
2	2B	data input
3	1A	data input
4	1B	data input
5	1C	data input
6	1Y	data output
7	GND	ground (0V)
8	2C	data input
9	2Y	data output
10	3Y	data output
11	3C	data input
12	3B	data input
13	3A	data input
14	V _{DD}	supply voltage

Function Table

Input			Output
nA	nB	nC	nY
L	X	X	H
X	L	X	H
X	X	L	H
H	H	H	L

Note: H=HIGH voltage level; L=LOW voltage level; X=don't care.

Electrical Parameter

Absolute Maximum Ratings

(Voltages are referenced to GND (ground=0V), unless otherwise specified.)

Parameter	Symbol	Conditions	Min.	Max.	Unit
supply voltage	V_{DD}	-	-0.5	+18	V
DC input current	I_{IK}	any one input	-	± 10	mA
input voltage	V_I	all inputs	-0.5	$V_{DD}+0.5$	V
storage temperature	T_{stg}	-	-65	+150	°C
total power dissipation	P_{tot}	-	-	500	mW
device dissipation	P	per output transistor	-	100	mW
Soldering temperature	T_L	10s		260	°C

Note:1、 Absolute Maximum Ratings indicate limits beyond which damage to the device may occur. Operating Ratings indicate conditions for which the device is intended to be functional, but specific performance is not ensured.

- For DIP14 packages: above 70°C the value of P_{tot} derates linearly with 12mW/K.
- For SOP14 packages: above 70°C the value of P_{tot} derates linearly with 8mW/K.
- For (T)SSOP14 packages: above 60°C the value of P_{tot} derates linearly with 5.5mW/K.

Recommended Operating Conditions

Parameter	Symbol	Conditions	Min.	Typ.	Max.	Unit
supply voltage	V_{DD}	-	3	-	15	V
ambient temperature	T_{amb}	in free air	-40	-	+105	°C

Electrical Characteristics
DC Characteristics 1

 (T_{amb}=25°C, voltages are referenced to GND (ground=0V), unless otherwise specified.)

Parameter	Symbol	Conditions (V)			T _{amb} =25°C			Unit
		V _O	V _{IN}	V _{DD}	Min.	Typ.	Max.	
supply current	I _{DD}	-	0, 5	5	-	0.01	0.25	uA
		-	0, 10	10	-	0.01	0.5	uA
		-	0, 15	15	-	0.01	1	uA
LOW-level output current	I _{OL}	0.4	0, 5	5	0.51	1	-	mA
		0.5	0, 10	10	1.3	2.6	-	mA
		1.5	0, 15	15	3.4	6.8	-	mA
HIGH-level output current	I _{OH}	4.6	0, 5	5	-0.51	-1	-	mA
		2.5	0, 5	5	-1.6	-3.2	-	mA
		9.5	0, 10	10	-1.3	-2.6	-	mA
		13.5	0, 15	15	-3.4	-6.8	-	mA
LOW-level output voltage	V _{OL}	-	0, 5	5	-	0	0.05	V
		-	0, 10	10	-	0	0.05	V
		-	0, 15	15	-	0	0.05	V
HIGH-level output voltage	V _{OH}	-	0, 5	5	4.95	5	-	V
		-	0, 10	10	9.95	10	-	V
		-	0, 15	15	14.95	15	-	V
LOW-level input voltage	V _{IL}	0.5, 4.5	-	5	-	-	1.5	V
		1, 9	-	10	-	-	3	V
		1.5, 13.5	-	15	-	-	4	V
HIGH-level input voltage	V _{IH}	4.5	-	5	3.5	-	-	V
		9	-	10	7	-	-	V
		13.5	-	15	11	-	-	V
input leakage current	I _I	-	0, 15	15	-	±10 ⁻⁵	±0.1	uA

DC Characteristics 2

(Tamb=-40°C to +105°C, voltages are referenced to GND (ground=0V), unless otherwise specified.)

Parameter	Symbol	Conditions (V)			Tamb=-40°C		Tamb=+85°C		Tamb=+105°C		Unit
		VO	VIN	VDD	Min.	Max.	Min.	Max.	Min.	Max.	
supply current	IDD	-	0, 5	5	-	0.25	-	7.5	-	7.5	uA
		-	0, 10	10	-	0.5	-	15	-	15	uA
		-	0, 15	15	-	1	-	30	-	30	uA
LOW-level output current	IOL	0.4	0, 5	5	0.61	-	0.42	-	0.36	-	mA
		0.5	0, 10	10	1.5	-	1.1	-	0.9	-	mA
		1.5	0, 15	15	4	-	2.8	-	2.4	-	mA
HIGH-level output current	IOH	4.6	0, 5	5	-0.61	-	-0.42	-	-0.36	-	mA
		2.5	0, 5	5	-1.8	-	-1.3	-	-1.15	-	mA
		9.5	0, 10	10	-1.5	-	-1.1	-	-0.9	-	mA
		13.5	0, 15	15	-4	-	-2.8	-	-2.4	-	mA
LOW-level output voltage	VOL	-	0, 5	5	-	0.05	-	0.05	-	0.05	V
		-	0, 10	10	-	0.05	-	0.05	-	0.05	V
		-	0, 15	15	-	0.05	-	0.05	-	0.05	V
HIGH-level output voltage	VOH	-	0, 5	5	4.95	-	4.95	-	4.95	-	V
		-	0, 10	10	9.95	-	9.95	-	9.95	-	V
		-	0, 15	15	14.95	-	14.95	-	14.95	-	V
LOW-level input voltage	VIL	4.5	-	5	-	1.5	-	1.5	-	1.5	V
		9	-	10	-	3	-	3	-	3	V
		13.5	-	15	-	4	-	4	-	4	V
HIGH-level input voltage	VIH	0.5,4.5	-	5	3.5	-	3.5	-	3.5	-	V
		1.9	-	10	7	-	7	-	7	-	V
		1.5,13.5	-	15	11	-	11	-	11	-	V
input leakage current	Ii	-	0, 15	15	-	±0.1	-	±1	-	±1	uA

AC Characteristics

(Tamb=25°C, GND=0V, tr, tf=20ns, CL=50pF, RL=200kΩ, unless otherwise specified.)

Parameter	Symbol	Conditions	Min.	Typ.	Max.	Unit	
propagation delay time	tPHL, tPLH	see Figure 4	VDD=5V	-	125	250	ns
			VDD=10V	-	60	120	ns
			VDD=15V	-	45	90	ns
transition time	tTHL, tTLH	see Figure 4	VDD=5V	-	100	200	ns
			VDD=10V	-	50	100	ns
			VDD=15V	-	40	80	ns
input capacitance	CI	any input	-	5	7.5	pF	

AC Testing Circuit

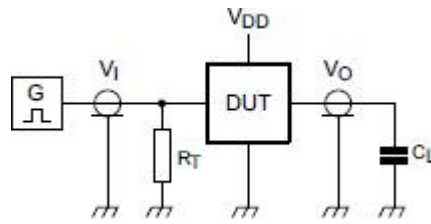

Figure 3. Test circuit for switching times

Definitions for test circuit:

DUT=Device Under Test.

C_L =Load capacitance including jig and probe capacitance.

R_T =Termination resistance should be equal to the output impedance Z_o of the pulse generator.

AC Testing Waveforms

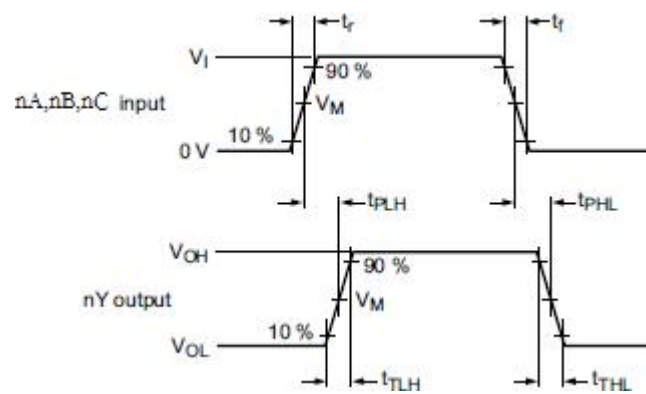

Figure 4. Propagation delay, output transition time

Measurement Points

Supply voltage	Input	Output
VDD	VM	VM
5V to 15V	$0.5 \times V_{DD}$	$0.5 \times V_{DD}$

Test Data

Supply voltage	Input	Load
VDD	VI	CL
5V to 15V	GND or VDD	50pF

Physical Dimensions

DIP-14

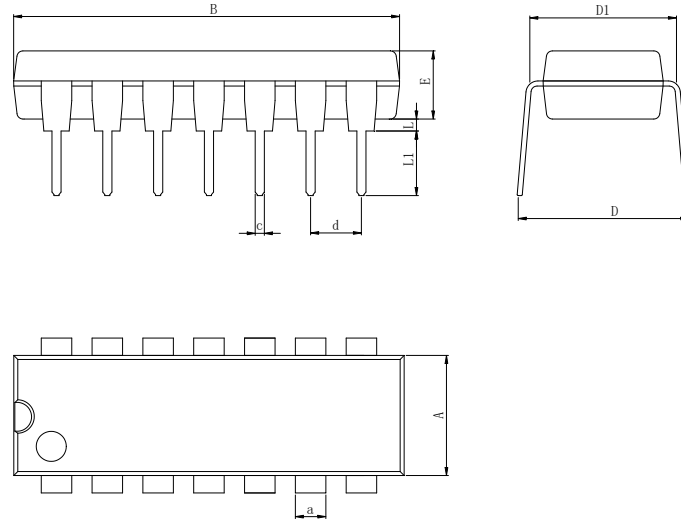

Dimensions In Millimeters(DIP-14)										
Symbol:	A	B	D	D1	E	L	L1	a	c	d
Min:	6.10	18.94	8.10	7.42	3.10	0.50	3.00	1.50	0.40	2.54 BSC
Max:	6.68	19.56	10.9	7.82	3.55	0.70	3.60	1.55	0.50	

SOP-14

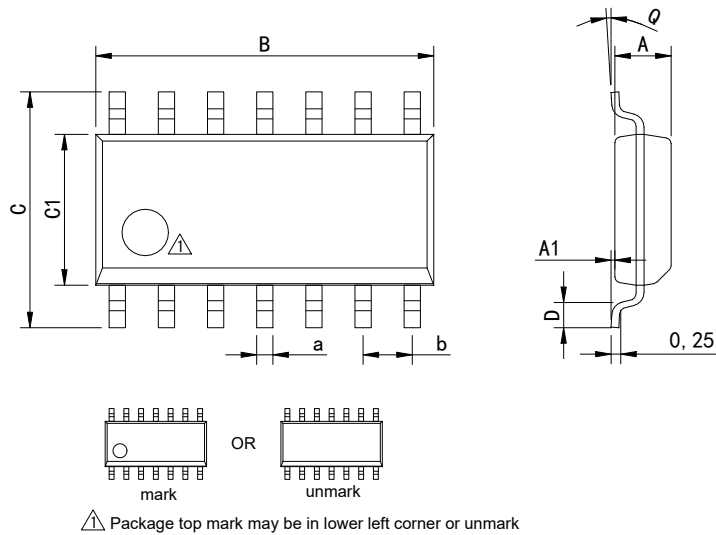

Dimensions In Millimeters(SOP-14)									
Symbol:	A	A1	B	C	C1	D	Q	a	b
Min:	1.35	0.05	8.55	5.80	3.80	0.40	0°	0.35	1.27 BSC
Max:	1.55	0.20	8.75	6.20	4.00	0.80	8°	0.45	

Physical Dimensions

TSSOP-14

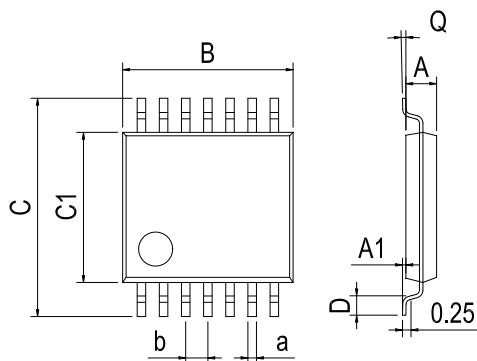

Dimensions In Millimeters(TSSOP-14)									
Symbol:	A	A1	B	C	C1	D	Q	a	b
Min:	0.85	0.05	4.90	6.20	4.30	0.40	0°	0.20	0.65 BSC
Max:	0.95	0.20	5.10	6.60	4.50	0.80	8°	0.25	

Revision History

REVISION NUMBER	DATE	REVISION	PAGE
V1.0	2012-3	New	1-10
V1.1	2015-11	Update encapsulation type、Updated DIP-14 dimension、Update DIP Package New Model	1、 7
V1.2	2017-6	Add annotation for Maximum Ratings	3
V1.3	2024-10	Update Lead Temperature	3
V1.4	2025-11	Update important statements、 Update SOP-14 Dimension drawing	7、 10

IMPORTANT STATEMENT:

Huaguan Semiconductor reserves the right to change products and services offered without prior notice. Customers should obtain the latest relevant information before placing orders and verify that such information is current and complete. Huaguan Semiconductor assumes no responsibility or liability for altered documents.

Customers are responsible for complying with safety standards and implementing safety measures when using Huaguan Semiconductor products in system design and end-product manufacturing. You assume full responsibility for: selecting the appropriate Huaguan Semiconductor products for your application; designing, validating, and testing your application; and ensuring that your application complies with applicable standards and all other safety, security, or other requirements. This is to prevent potential risks that may lead to personal injury or property damage.

Huaguan Semiconductor products are not approved for use in life support, military, aerospace, or other high-risk applications. Huaguan products are neither intended nor warranted for use in such systems or equipment. Any failure or malfunction may lead to personal injury or severe property damage. Such applications are deemed "Unsafe Use." Unsafe Use includes, but is not limited to: surgical and medical equipment, nuclear energy control equipment, aircraft or spacecraft instruments, control or operation of vehicle power, braking, or safety systems, traffic signal instruments, all types of safety devices, and any other applications intended to support or sustain life. Huaguan Semiconductor shall not be liable for consequences resulting from Unsafe Use in these fields. Users must independently evaluate and assume all risks. Any issues, liabilities, or losses arising from the use of products beyond their approved applications shall be solely borne by the user. Users may not claim any compensation from Huaguan Semiconductor based on these terms. If any third party claims against Huaguan Semiconductor due to such Unsafe Use, the user shall compensate Huaguan Semiconductor for all resulting damages and liabilities.

Huaguan Semiconductor provides technical and reliability data (including datasheets), design resources (including reference designs), application or other design advice, web tools, safety information, and other resources for its semiconductor products. However, no guarantee is made that these resources are free from defects, and no express or implied warranties are provided. The use of testing and other quality control techniques is limited to Huaguan Semiconductor's quality assurance scope. Not all parameters of each device are tested.

Huaguan Semiconductor's documentation authorizes you to use these resources only for developing applications related to the products described herein. You are not granted rights to any other intellectual property of Huaguan Semiconductor or any third party. Any other reproduction or display of these resources is strictly prohibited. You shall fully indemnify Huaguan Semiconductor and its agents against any claims, damages, costs, losses, and liabilities arising from your use of these resources. Huaguan Semiconductor shall not be held responsible.