

APPROVAL SHEET

Customer:

Customer Part NO.

Part NO.

CD100M100G10PC97V00A

Item:

10uF/100V

Catalog Series:

CD Series





Date of Issue:

MAY.22.2025

Approved NO. :

SD20250500703

BUYER'S STAMP	Approved by			

<i>Su'scon</i>	Submitted by			
	Approval	Check	Affirm	Design
 <p>東莞冠坤電子有限公司 發行 2025-05-22 工程部</p>	 <p>工程部 2025-05-22 鐘華</p>	 <p>工程部 2025-05-22 張家英</p>	 <p>工程部 2025-05-22 莫明強</p>	 <p>工程部 2025-05-22 賴彤影</p>

Su'scon



DONG GUAN HEYUE ELECTRONIC CO., LTD

TEL:0769-8308 6886
FAX:0769-8308 6886
Mail : sales016@heyuecap.com

Halogen
Free
RoHS COMPLIANT Environmental-Benefit Products

RECORD OF REVISION

NO.	VERSION	REASON	DATE	CHECKED	REMARKS
1	A00	First Release	2025.05.22	劉冬冬	
2					
3					
4					
5					
6					
7					
8					
9					
10					
11					
12					
13					
14					
15					
16					
17					
18					
19					
20					
21					
22					
23					
24					
25					
26					
27					
28					
29					
30					

CD Specification For Approval

NO.	Customer Part No.	Specification	<i>Su'scon</i> Part No.
1		EC,10uF/100V	CD100M100G10PC97V00A
2			
3			
5			
4			
6			
7			
8			
9			
10			
11			
12			
13			
14			
15			
16			
17			
18			
19			
20			
21			
22			
23			
24			
25			
26			
27			

Explanation of Parts Numbers (ERP System)

Draw Up:1999.12.15
Revise:2016.06.15

Codification:DKK/III-00-002
Edition:A08

Explanation of Parts Numbers

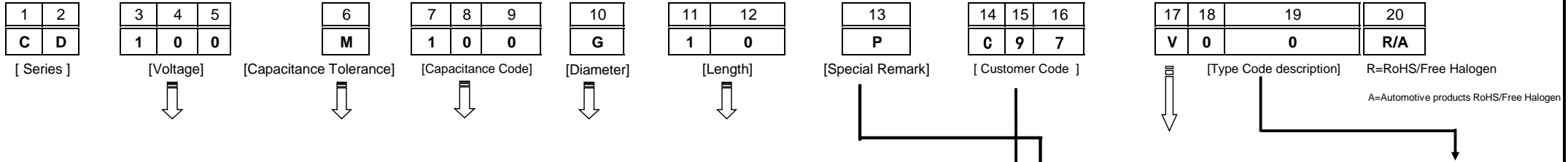

004=4V	J= ±5 %	0R1=0.1uF	C=4Φ
006=6.3V	K= ±10%	1R0=1uF	D=5Φ
010=10V	M= ±20 %	100=10 uF	5=5.5Φ
016=16V	A= 0 %~+20 %	101=100 uF	E=6.3Φ
025=25V	S= 0 %~+40 %	102=1000 uF	V=6.5Φ
035=35V	R= 0 %~+50 %	103=10000 uF	F=8Φ
050=50V	D= -5 %~+20 %	223=22000 uF	G=10Φ
063=63V	V= -10 %~+20 %	G52=1650 uF	H=12Φ
080=80V	Q= -10 %~+30 %		X=12.5Φ
100=100V	T= -10 %~+50 %		I=13Φ
160=160V	E= -15 %~+20 %	P=35Φ	Y=14.5Φ
350=350V	I= -30 %~+20 %	Q=40Φ	J=16Φ
400=400V	B= +10 %~+30 %	W=42Φ	K=18Φ
420=420V	N= +10 %~+25 %	8=45Φ	L=20Φ
450=450V	C= -5 %~+15 %	R=51Φ	M=22Φ
500=500V	Z= -0 %~+30 %	S=64Φ	N=25Φ
		T=76Φ	Z=25.4Φ
		U=90Φ	O=30Φ

1) Length < 100mm Integer, Input it direct.
2) Length < 100mm Decimal, Please refer the code as below: Ex:11.5 isBB; 5.4 is 5A;
3. Length ≥ 100mm, First digit input No.0~9 · 2nd · 3rd refer as below Code11 Ex:115, Input B5.

Code 11 · 18	Meaning
A	10
B	11
C	12
D	13
E	14
F	15
G	16
H	17
I	18
J	19
K	20
Q	21

Code 12 · 19	Meaning
A	0.4
B	0.5
C	0.6
D	0.7
E	0.8
F	0.9
G	0.1
H	0.2
I	0.3

Code 17	Code 18	Code 19	Code 20
B	0	0	R/A

RADIAL

- B=Forming Only
- C=Lead Cut
- D=Lead Cut and Crimp
- N=Lead spacing expand to 2.0 mm then Cut
- E=Lead spacing expand to 2.5 mm then Cut
- F=Lead Forming spacing 5.0 mm then Cut
- H=Lead Forming Cut and Crimp
- S=Long Lead
- L=Facing cathode:Lead Cut and Bending (turn right)
- Z=Facing cathode:Lead Cut and Bending (turn left)
- P=Taping (Ammo pack)
- R=Tape and Reel
- V=V-chip Type (SMD)

LUG

- G= LG Type Terminal
- PCS= PC board pin-out Straight Terminal
- PCY= PC board pin-out LUG Terminal
- PCU= PC board pin-out U-Insert Terminal
- PCB= PC board pin-out Bend Terminal
- ST= Straight Type Terminal
- U= 5 Pin Straight Terminal
- W= Screw Terminal
- YL= Snap

<1>Code No.17 is "P", "R" Code No.18 · 19 is stand for Lead pitch.
<2>Code No.17 is C,N,E,F,D,H,W,K,L,Z, Code No.18 · 19 is stand for Lead length.
<3>Code No.17 is S, Code No.18 · 19 be filled in "00" is stand for General Long Lead
<4>Code No.17 is "B", Code No.18 · 19 be filled in "00" is stand for Forming Long Lead
<5>Code No.17 is "V", Code No.18 · 19 be filled in "00" is Fill code number, does not mean other significance

Code 13	Meaning
T	Convex Rubber seal (Standard : Lead Type 12.5Φ ≤ D ≤ 18Φ (Breathe freely))
P	Flat Rubber seal (Standard : Lead Type 4Φ ≤ D ≤ 12Φ : 20Φ · 22Φ · 25Φ)
0	Snap-in, U-LUG Type

KKK	For Standard Product which has no artifictious. (Bulk, Long-lead, No partcular processing, rated spec.)
C97	Customer No.

2.ERP P/N System compare with NCC's Description

- "Finished Products" ----20 Codes ·
- Snap in Type---- "Semi-finished products P/N" has not demand · It's also 20 Codes
- Lead Type---- 16 codes for "Semi-finished products" · It's 16 codes (If Specially enquire and 16 codes can not be reached, It will be 20 code for that)
- Codes No.13 : Specially Code · It's difference between clients enquire and same Spec multiple enquired.
- Codes No.14~16 which is for clients Code.
- Length of Lead Cut and Forming bigger than 10.0mm or appendix digit · Letters Description ·

FOR APPROVAL

DIMENSIONS(mm)

■ Chip Type

Fig.1 ΦD=4~10mm

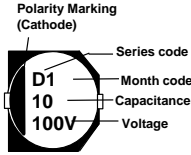
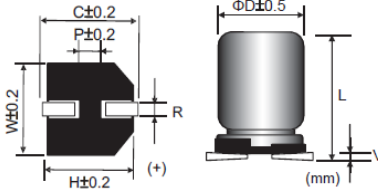
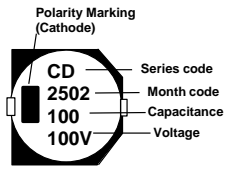

Fig.2 ΦD≥12.5mm



Size	ΦD	L	W	H	C	R	P	Vmax
4*5.4	4.0	5.4±0.3	4.3	4.3	5.1	0.5~0.8	1.0	0.3
5*5.4	5.0	5.4±0.3	5.3	5.3	5.9	0.5~0.8	1.4	0.3
6.3*5.4	6.3	5.4±0.3	6.6	6.6	7.2	0.5~0.8	2.1	0.3
6.3*6	6.3	6.0±0.3	6.6	6.6	7.2	0.5~0.8	2.1	0.3
6.3*7.7	6.3	7.7±0.3	6.6	6.6	7.2	0.5~0.8	2.1	0.3
8*6.5	8.0	6.5±0.5	8.3	8.3	9.0	0.5~0.8	2.3	0.3
8*10	8.0	10±0.5	8.3	8.3	9.0	0.7~1.1	3.2	0.3
10*7.7	10.0	7.7±0.5	10.3	10.3	11.0	0.7~1.3	4.5	0.3
10*10	10.0	10±0.5	10.3	10.3	11.0	0.7~1.3	4.5	0.3
16*16.5	16.0	16.5±0.5	17.0	17.0	18.0	1.4~1.8	6.4	0.4

Customer:	Aluminum Electrolytic Capacitors	Su'scon
	CD Series	Code

Electric Characteristics:													
P/N	P/N	Cap. (uF)	Cap. Tol. (%)	Rate Volt. (V-DC)	Surge Volt. (V-DC)	Oper. Temp. (°C)	Nominal Case Size D*L(mm)	Leakage Current Max (uA)	D.F. MAX (%)	R.C 100KHz (mA rms)	IMP 100KHz at 25°C (Q)Max	Load Life (hours)	
	CD100M100G10PC97V00A	10	±20	100	115.0	105	10*10	10	7	240	0.800	3000	

REMARKS:

- Leakage Current Test:** 6.3V ~100V at 20°C for 2 minutes ;
- Operating temperature:** 6.3V~100V -55°C ~ +105°C ;
- .Dissipation Factor Test:** at 20°C, 120 Hz.
- Capactitance Test:** at 20°C, 120 Hz.
- Ripple Current Test:** at 105°C, 100K Hz ;
- Load Life:** 3000 hours, with application of rated voltage at 105°C.
(L<10mm, 2000 hours;)

Capacitance Change: Within ±30% of initial value;
tanδ: 300% or less of initial specified value;
Leakage Current: Initial specified value or less;

7. Shelf Life: The following specifications shall be satisfied when the capacitors are restored to 20°C after exposing them for 1000 hours 105°C without voltage applide. Before the measurement, the capacitor shall be preconditioned by applying voltage according to them 4.1 of JIS C5101-4.

Capacitance Change: Within ±30% of initial value;
tanδ: 300% or less of initial specified value;
Leakage Current: Initial specified value or less;

8. when have characteristic requested : Load life & shelf life test and etc. , judgment standard reference to our catalogue.

9.Remarks: Su'scon Part Number with suffix code "A" is specially offered for automotive project, which meets AEC-Q200 standard.

●SPECIFICATION

Leakage Current 洩漏電流	After 2 minutes application of rated voltage,leakage current is not more than 0.01cv or 3(uA),whichever is greater.											
Dissipation Factor 散逸因素 (損失角) (tan δ)	Measurement Frequency:120Hz. Temperature:20°C											
	Rate Voltage(V)	6.3	10	16	25	35	50	63	80	100		
	tan δ (MAX)	0.30	0.26	0.22	0.16	0.13	0.10	0.08	0.08	0.07		
Low Temperature Stability 低溫特性	Measurement Frequency:120Hz.											
	Rate Voltage(V)	6.3	10	16	25	35	50	63	80	100		
	Impedance Ratio(MAX) 阻抗比率(MAX)	Z(-25°C)/Z(20°C)	4	3	2	2	2	2	2	2	2	2
	Z(-55°C)/Z(20°C)	8	5	4	3	3	3	3	3	3	3	

●Frequency Coefficient of Permissible Ripple Current

Frequency(Hz)	120 ≤ F< 1K	1K ≤ F< 10K	10K ≤ F< 100K	100K ≤ F
≤ 33	0.35	0.70	0.90	1.00
33~150	0.40	0.85	0.92	1.00
>150	0.60	0.85	0.95	1.00

7

Characteristics of temperature
溫度特性

STEP 步驟	TEMPERATURE 溫度	STORAGE TIME 放置時間
1	20°C ± 2 °C	30 minutes
2	-55°C ± 3 °C	2 hours
3	20°C ± 2 °C	30 minutes
4	105°C ± 2°C	2 hours

Step 1. Measure the capacitance and impedance.

測定靜電容量及阻抗 (Z r0) .(| Z | , 20°C , 120Hz ± 10%)

Step 2. Measure the impedance at thermal balance after 2 hours.

達到熱平衡2小時後， 測定阻抗 (Zr) .(| Z | , -55 °C , 120Hz ± 10%)

Impedance ratio (Zr / Z r0) less than specified value.

阻抗比：低于規定值 .

Step 4. Measure the capacitance and leakage current at thermal balance after 2 hours.

達到熱平衡2小時後， 測定靜電容量及漏電流 .

Capacitance change :within ± 20% of the initial measured value.

靜電容量變化：最初測定值的± 20%以內.

Leakage current :Less than 10 times of initial specified value .

漏電流： 初期規格值的10倍以內.

Measuring frequency : 120HZ

spec:	Rated Voltage(V)	6.3	10	16	25	35	50	63	80	100
Z(-25°C)/Z(20°C)	4	3	2	2	2	2	2	2	2	2
Z(-55°C)/Z(20°C)	8	5	4	3	3	3	3	3	3	3

8

Surge voltage Test
突波試驗

Rated surge voltage shall be applied (switch on) for 30 ± 5 seconds and then shall be applied (switch off) with discharge for 5.5 ± 0.5 min. at room temperature . This cycle shall be repeated for 1,000 cycles . Duration of one cycle is 6 ± 0.5 minutes .

在常溫下，施加(開關通路)額定突波電壓 30 ± 5 秒，然後停止施加(開關斷路)突波電壓。

並放電 5.5 ± 0.5 分鐘.這個周期重复1000 次.以 6 ± 0.5分鐘為一循環周期 .

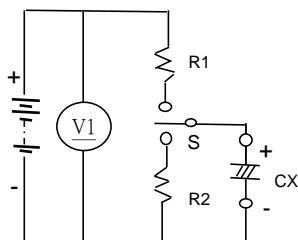

Surge voltage

突波電壓

Protective series resistor(1kΩ)

R1:保護電阻

Test capacitor

CX: 測試電容

DC voltmeter

V1 : DC 電壓計

Discharge resistor(1kΩ)

R2:放電電阻

Switch

S:開關

spec: Capacitance change : within ±15% of the initial measured value.

靜電容量變化：最初測定值的 ±15%以內.

Dissipation factor: initial specified value or less.

損失角：低于規定值

Leakage current : initial specified value or less.

漏電流：低于規定值

Rated Voltage(WV)	4	6.3	10	16	25	35	50	63	80	100
Surge Voltage(SV)	4.6	7.2	11.5	18.4	28.8	40.3	57.5	72.5	92	115

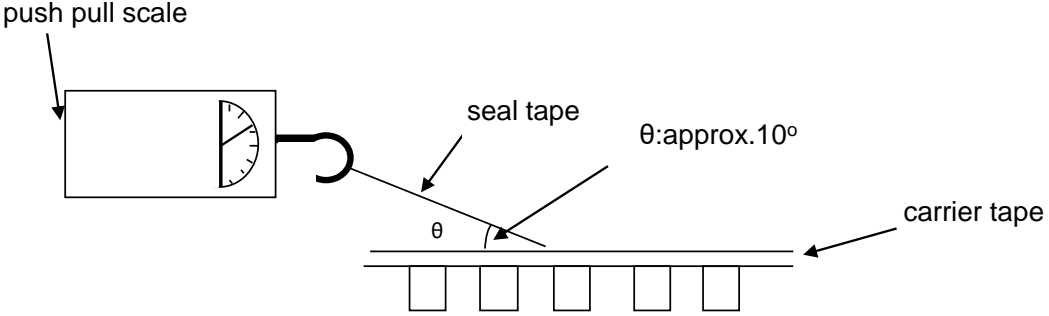
9	<p>Adhesion Test 密著性試驗方法</p>	<p>Reasonable pulling strength:0.1~0.7N 最適當拉張度之強度:0.1~0.7N</p> <p>Pulling speed:300mm/min 拉扯之速度:300mm/min</p> 
10	<p>Solder ability 焊錫性</p>	<p>The leads are dipped in the solder bath of Sn at $245 \pm 5 \text{ }^\circ\text{C}$ for 3 ± 0.5 seconds . The dipping depth should be set at 1.5 ~ 2.0 mm . 端子浸沒在 $245 \pm 5 \text{ }^\circ\text{C}$ 的錫焊液中 3 ± 0.5 秒 . 浸沒深度設定為 1.5 ~ 2.0 mm .</p> <p>spec: The solder alloy shall cover the 95% or more of the dipped lead's area . 錫液要覆蓋導針浸入表面積的 95% 以上 .</p>
11	<p>Resistance to soldering heat 焊錫耐熱性</p>	<p>The leads immerse in the solder bath of Sn at $250 \pm 5 \text{ }^\circ\text{C}$ for 30 ± 1 seconds until a distance of 1.5~ 2mm from the case . 導針在 $250 \pm 5 \text{ }^\circ\text{C}$ 的錫焊液中浸沒至離本體 1.5 ~ 2 mm 的地方 30 ± 1 秒鐘 .</p> <p>spec: No damage or leakage of electrolyte . 無損傷或電解液漏出 .</p> <p>Capacitance change :within $\pm 10\%$ of the initial measured value . 容量變化 :最初測定值的 $\pm 10\%$ 以內 .</p> <p>Dissipation factor : initial specified value or less . 損失角 : 低於規定值 .</p> <p>Leakage current : initial specified value or less . 洩漏電流 : 低於規定值 .</p>
12	<p>Vibration 耐振性</p>	<p>The frequency of the vibration shall vary uniformly within the range 10 to 55 Hz with the amplitude of 1.5 mm , completing the cycle in the internal of one minute . The capacitor shall be securely mounted by its leads with hold the body of capacitor . The capacitor shall be vibrated in three mutually perpendicular directions for a period of 2 hours in each direction .(a total 6 hours) 振動頻率要均勻 , 範圍為 10 Hz , 到 55 Hz , 振幅為 1.5 mm , 在 1 分鐘內完成該循環 . 電容器將由端子牢固地固定 . 電容器會被向三個互相垂直的方向每個方向 振動 2 小時 . (總時間為6小時)</p> <p>spec Capacitance : no unsteady . 靜電容量 : 穩定 .</p> <p>Appearance : no abnormal . 外觀 : 無異常 .</p> <p>Capacitance change: within $\pm 5\%$ of initial measured value . 容量變化 : 最初測定值的 $\pm 5\%$ 以內 .</p>

13	<p>Damp heat (steady state) 耐濕性 (穩定狀態)</p>	<p>Subject the capacitors to $40 \pm 2^{\circ}\text{C}$ and 90% to 95% relative humidity for 500 ± 8 hours . 電容器在 $40 \pm 2^{\circ}\text{C}$ 及相對濕度 90% ~ 95% 的條件下經歷 500 ± 8 小時 .</p> <p>spec: Capacitance change :within $\pm 10\%$ of the initial measured value . 容量變化 : 最初測定值的 $\pm 10\%$ 以內 .</p> <p>Dissipation factor : initial specified value or less. 損失角 : 低於規定值 .</p> <p>Leakage current : initial specified value or less. 洩漏電流 : 低於規定值 .</p>
14	<p>Shelf life 高溫無負荷</p>	<p>The following specifications shall be satisfied when the capacitors are restored to 20°C . after exposing them for 1,000 hours at 105°C , without voltage applied. During testing The rated voltage shall be applied to the capacitors for a minimum of 30 minutes, at least 24 hours and not more than 48 hours before the measurements. 在未加電壓下情形下,電容器置於環境溫度 105°C 1000 小時後 在 20°C 的環境下測試需符合標準. 測試時須放於室溫最最少24小時不超過48小時, 印加額定電壓30分鐘進行測試.</p> <p>spec: 1,000hours, no voltage applied, at 105°C . After Test:UR to be applied for 30 minutes, 24 to 48 hours before measurement. They meet the specified value for endurance characteristics listed above.</p>
15	<p>Load life 高溫負荷</p>	<p>The following specifications shall be satisfied when the capacitors are restored to 20°C after the rated voltage applied for 3,000 hours (L<10mm, 2000 hours;) . at 105°C 印加額定電壓情形下, 電容器置於環境溫度 105°C 3,000小時(L<10mm, 2000小時;) 後在 20°C 環境下測試需符合標準.</p> <p>spec: Capacitance change : within $\pm 30\%$ of the initial measured value. 靜電容量變化 : 最初測定值的 $\pm 30\%$ 以內.</p> <p>Dissipation factor : 300% or less of initial specified value. 損失角 : 低於最初規定值的 300%.</p> <p>Leakage current : initial specified value or less. 洩漏電流 : 低於規定值</p>
16	<p>Storage at low temperature 低溫貯存</p>	<p>The capacitor shall be stored at temperature of $-40 \pm 3^{\circ}\text{C}$ for 16(-0/+2) hours , during which time no voltage shall be applied . And then the capacitor shall be subjected to standard atmospheric conditions for 16 hours or more , after which measurements shall be made . 電容器貯存在 $-40 \pm 3^{\circ}\text{C}$ 中 達 16(-0/+2) 小時, 其間不施加電壓 . 之後, 在標準大氣壓中露置 16 小時以上, 然後進行測試 .</p> <p>spec: Capacitance change : within $\pm 10\%$ of the initial measured value. 電容量變化 : 最初測定值的 $\pm 10\%$ 以內.</p> <p>Dissipation factor : initial specified value or less. 損失角 : 低於規定值 .</p> <p>Leakage current : initial specified value or less. 洩漏電流 : 低於規定值 .</p> <p>Appearance : no abnormal . 外觀 : 無異常 .</p>

Reflow Soldering Test

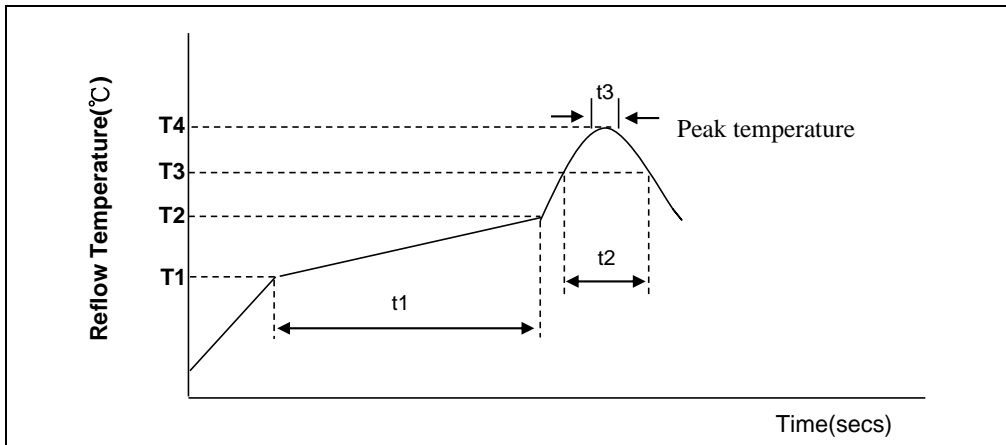

Test conditions

Profile Feature	Pb Free Assembly	
	4~6.3Ø	8~16Ø
Average Ramp-up Rate	3°C/second max	3°C/second max
Preheat		
Temperature Min(T1 min)	150°C	150°C
Temperature Max(T2 max)	180°C	180°C
Time (t1 Max)	120secs	120secs
Ramp-up Rate (T2 ~T3)	3°C/second max	3°C/second max
Time maintained above Temperature(T3)	217°C	217°C
Time(t2 Max)	90secs	40secs
Peak Temperature(T4)	260°C	245°C
Time(t3 Max)	5secs	5secs
Reflow cycles	1	2 or less

* Please ensure that the capacitor became cold enough to the room temperature(5~35°C) before the second reflow.

17 Reflow Soldering Temperature Profile
回焊爐測試

18 Standards
參考標準

JIS C-5101-4(IEC 60384)

Marking :

Fig.1 ΦD=4~10mm

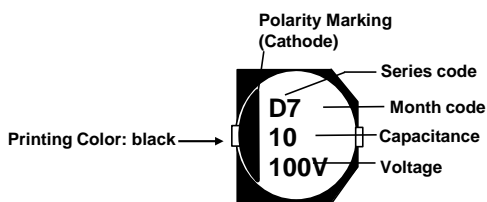
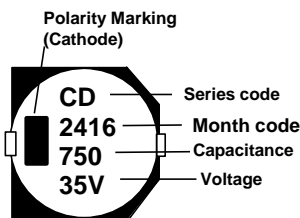

Fig.2 ΦD ≥ 12.5mm



1.Series name:

Fig.1	Code	S	H	N	K	D	DL	Fig.2	CS	CH	CN	CK	CD	CDL
	Series	CS	CH	CN	CK	CD	CDL		CS	CH	CN	CK	CD	CDL

2.Month code:

Fig.1	Code	1	4	7	O	Fig.2	Date Code	Production Date
	Month	1~3	4~6	7~9	10~12		2116	The 16th week of 2021Y

3.Capacitance:

Code	10	100	1000
Capacitance (uF)	10	100	1000

4.Working voltage:

Code	4V	6.3V	10V	16V	25V	35V	50V	63V	80V	100V
WV (V)	4V	6.3V	10V	16V	25V	35V	50V	63V	80V	100V

鋁電解電容器存放環境與控制

Storage Conditions and Control for Aluminum Electrolytic Capacitor

1. 環境溫度：5°C ~ 35°C，環境相對濕度：75%以下。

Store the capacitor at a temperature of 5°C to 35°C and at a relative humidity of less than 75% .

2. 存放環境不應有陽光直射，不宜高溫。

Store the capacitor in low temperature places free from direct sun shine .

3. 存放環境不能有鹽分、油含量高的霧氣。

Store the capacitor in places free from oil vapor、salt water vapor.

4. 存放在遠離氯氣、氨氣、硫化氫、亞硫酸、硝酸等有害氣體含量高的地方。

Store the capacitor in places far from toxic gases (chlorine、ammonium、hydrogen sulfide、sulphurous acid、nitric acid , etc) .

5. 儲存環境不能有臭氧、紫外線或輻射。

Store the capacitor in place free from Ozone、ultraviolet ray or radiation .

Detergent needing attention:

使用清潔劑之注意事項:

Hydrogen carbide liquid and halogen liquid can cause Aluminium Electrolytic Capacitor to corrode. Some of Safe and Unsafe detergent are as follows;

鋁質電解電容器會受含有碳化氫鹵素容劑之侵蝕,下列為各種安全與不安全之清潔劑,為避免不必要的損失,您所使用有關印刷基板之清潔劑名請事先告知本公司.

Safe 安全	Unsafe 不安全
Methanol 甲醇	1.1.2- trichloroethane 1.1.2- 三氯乙烷
Ethanol 乙醇	Tetrachloroethylene 四氯化碳
Propanol 丙醇	Chloroform(colorless volatilizable liquid) 哥羅仿(無色揮發性液體)
Butanol 丁醇	Dichloromethane 二氯甲烷
Detergent 去垢劑	Trichlorethylene 三氯甲烯
	Dimethybenzene 二甲苯

V-Chip Aluminum Electrolytic Capacitors

Structure and materials

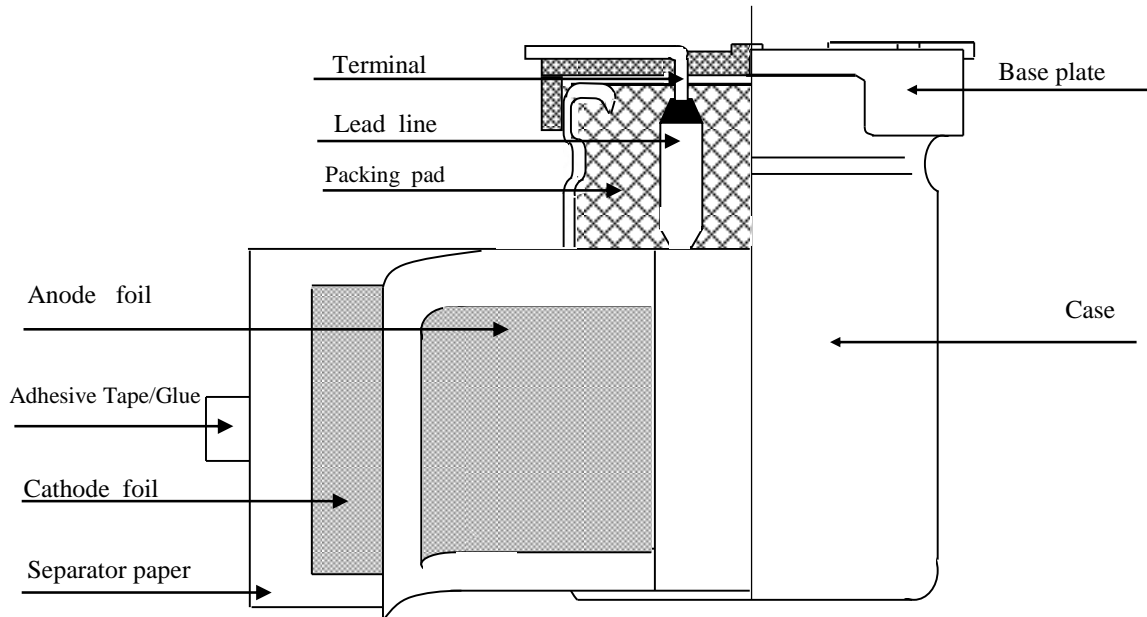

V-Chip type capacitors component

Part name	Materials
Terminal	Tin Coated Copper Covered Steel Wire
Lead line	Aluminum 99.90%
Packing pad	Synthetic rubber
Anode Foil	Formed aluminum 99.9% over
Cathode Foil	Formed aluminum 98.1% over
Separator paper	Manila Espartos
Adhesive Tape/Glue	Phenylene Sulfide ;Glue:PVA
Base plate	Polyphenylene oxide;Glass fibre
Case	Aluminum 98%+PU coating

6. PRECAUTIONS AND GUIDELINES TO USERS

When using aluminum electrolytic capacitors, pay strict attention to the following:

1. Electrolytic capacitors for DC application require polarization.

Confirm the polarity. If used in reversed polarity, the circuit life may be shortened or the capacitor may be damaged. For use on circuits whose polarity is occasionally reversed, or whose polarity is unknown, use bi-polarized capacitors (BP-series).

Also, note that the electrolytic capacitor cannot be used for AC application.

2. Do not apply a voltage exceeding the capacitor's voltage rating.

If a voltage exceeding the capacitor's voltage rating is applied, the capacitor may be damaged as leakage current increases.

When using the capacitor with AC voltage superimposed on DC voltage, care must be exercised that the peak value of AC voltage does not exceed the rated voltage.

3. Do not allow excessive ripple current to pass.

Use the electrolytic capacitor at current values within the permissible ripple range. If the ripple current exceeds the specified value, request capacitors for high ripple current applications.

4. Ascertain the operating temperature range.

Use the electrolytic capacitors according to the specified operating temperature range. Usage at room temperature will ensure longer life.

5. The electrolytic capacitor is not suitable for circuits in which charge and discharge are frequently repeated.

If used in circuits in which charge and discharge are frequently repeated, the capacitance value may drop, or the capacitor may be damaged. Please consult our engineering department for assistance in these applications.

If the electrolytic capacitor is allowed to stand for a long time, its withstand voltage is liable to drop, resulting in increased leakage current. If the rated voltage is applied to such a product, a large leakage current occurs and this generates internal heat, which damaged the capacitor. If the electrolytic capacitor is allowed to stand for a long time, therefore, use it after giving voltage treatment. (However, the electrolytic capacitors can be guaranteed for 2 years if kept in the normal temperature.)

6. Be careful of temperature and time when soldering.

When soldering a printed circuit board with various components, care must be taken that the soldering temperature is not too high and that the dipping time is not too long. Other wise, there will be adverse effects on the electrical characteristics and insulation sleeve of electrolytic capacitors in the case of small-sized electrolytic capacitors, nothing abnormal will occur if dipping is performed at less than 260 °C for less than 10 seconds.

7. Do not place a soldering iron body of the capacitor.

The electrolytic capacitor is covered with a vinyl sleeve. If the soldering iron comes in contact with the electrolytic capacitor body during wiring, damage to the vinyl sleeve and/or case may result in defective insulation, or improper protection

8. Cleaning circuit boards after soldering.

Some solvents have adverse effects on capacitors.

Please refer to the next page.

9. Do not apply excessive force to the lead wires or terminals.

If excessive force is applied to the lead wires and terminals, they may

be broken or their connections with the internal elements may be affected. (For strength of terminals, refer to

JIS C5101-1, JIS C5101-4)

10. Care should be used in selecting a storage area.

If electrolytic capacitors are exposed to high temperatures caused by such things as direct sunlight, the life of the capacitor may be adversely affected. Storage in a high humidity atmosphere may affect the solderability of lead wires and terminals.

11. Surge voltage:

Rated surge voltage shall be applied for 30 seconds and then shall be applied with discharge, for 330 seconds at room temperature. This cycle shall be repeated for 1000 cycles; Duration of one cycle is 6 minutes; then to judge capacitor's characteristics and appearance.

Rated Voltage(WV)	4	6.3	10	16	25	35	50	63	80	100
Surge Voltage(SV)	4.6	7.2	11.5	18.4	28.8	40.3	57.5	72.5	92	115

For methods of testing, refer to JIS C 5101-1, JIS C 5101-4.

※ The above mentioned material according to EIAJRCR-2367B (issued in March, 2002), titled "Guideline of notabilia for aluminum electrolytic capacitors for use in electronic equipment". Please refer to the book for details.

Su'scon CAPACITORS PACKING INFORMATION

● V-CHIP REEL

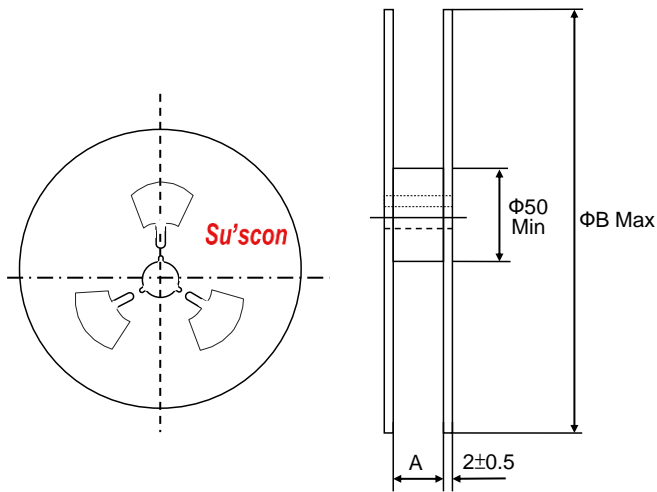

Package Quantity	
Size(Φ×L)	Q'ty/reel
Φ4	2000pcs
Φ5	1000pcs
Φ6.3×4~8L	1000pcs
Φ6.3×8.4L	800pcs
Φ8×(6~7L)	1000pcs
Φ8×(10~11)	500pcs
Φ10×(7~11)	500pcs
Φ10×(12~13)	400pcs
Φ10×(16~17)	300pcs
Φ12.5×(13~14)	250pcs
Φ12.5/16×(16~17)	200pcs
Φ16×(21~22)	125pcs
Φ18×(16~17)	150pcs
Φ18×(21~22)	100pcs

(單位：mm)

Size	Φ4~5	Φ6.3	Φ8	Φ10	Φ12.5	Φ16	Φ18
A	14	18	26	26	34	46	46
B	382	382	382	382	382	382	382

■ V-CHIP PACKAGE

● Carrier tape

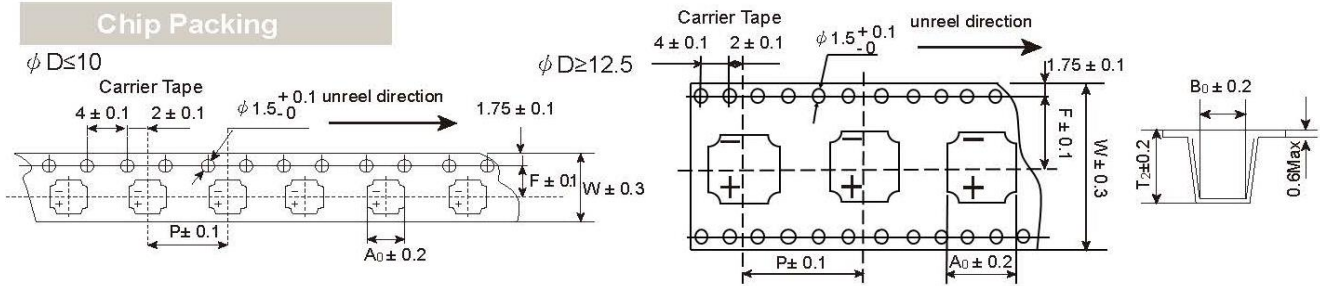

(單位：mm)

Size (Φ×L)	Item					
	W	P	F	A ₀	B ₀	T ₂
4 × 5.3~5.6L	12.0	8.0	5.5	5.0	5.0	5.8
4 × 5.7~6.3L	12.0	8.0	5.5	5.0	5.0	6.3
4 × 7L	12.0	8.0	5.5	5.0	5.0	7.5
5 × 5.3~5.6L	12.0	12.0	5.5	5.0	5.0	5.9
5 × 5.7~6.3L	12.0	12.0	5.5	5.0	5.0	6.3
5 × 6.4~7.0L	12.0	12.0	5.5	5.0	5.0	7.6
6.3 × 4.5L	16.0	12.0	7.5	7.0	7.0	4.8
6.3 × 5.4~5.6 L	16.0	12.0	7.5	7.0	7.0	5.9
6.3 × 5.7~6.3L	16.0	12.0	7.5	7.0	7.0	6.5
6.3 × 7~8L	16.0	12.0	7.5	7.0	7.0	8.3
6.3 × 8.1~9L	16.0	12.0	7.5	7.0	7.0	9.3
8 × 6~7L	16.0	12.0	7.5	8.7	8.7	6.9
8 × 10~11L	24.0	16.0	11.5	8.7	8.7	11
10 × 7.7L	24.0	16.0	11.5	10.7	10.7	8.7
10 × 10~11L	24.0	16.0	11.5	10.7/11.4(G)	10.7/11.4(G)	11/11.4(G)
10 × 12~13L	24.0	16.0	11.5	10.7	10.7	13.1
10 × 16~17L	24.0	16.0	11.5	10.7	10.7	17.5
12.5 × 13~14L	32.0	24.0	14.2	13.4	13.4	15
12.5 × 16~17L	32.0	24.0	14.2	13.4	13.4	17.5
16× 16~17L	44.0	28.0	20.2	17.5	17.5	17.5
16× 21~22L	44.0	28.0	20.2	17.5	17.5	23
18× 16~17L	44.0	32.0	20.2	19.5	19.5	17.5
18× 21~22L	44.0	32.0	20.2	19.5	19.5	23

(G) "Anti-vibration Structure"

使用時注意事項:Precautions for users

1. 輕拿輕放 handle gently
2. 取出托盤時,請用手托住紙盤底部,以免電容鬆散. When take the tray out, pls support the bottom of the paper plate with your hands to avoid loose capacitors.