

Interface Transceiver of RS-232 Standard with One Supply Voltage

Features

- 300 μ A SUPPLY CURRENT
- 120Kbps MAX GUARENTEED DATA RATE
- 3V/ μ s MINIMUM GUARANTEED SLEW RATE
- ENHANCED ESD SPECIFICATIONS:
 - ±15kV IEC61000-4-2 Air Discharge
 - ±8kV IEC61000-4-2 Contact Discharge
- AVAILABLE IN DIP-16, SOP-16 AND TSSOP16

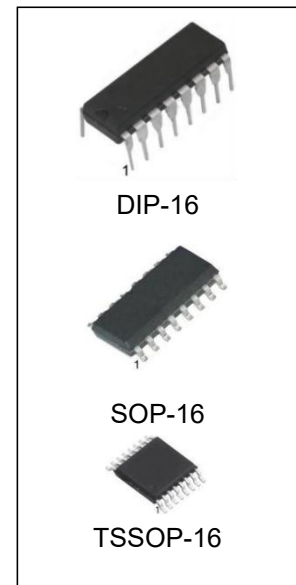

Ordering Information

Device	Package Type	Marking	Packing	Packing Qty
MAX3232CPE/HG	DIP-16	MAX3232C	TUBE	1000pcs/box
MAX3232CSE/HG	SOP-16	MAX3232C	REEL	2500pcs/reel
MAX3232CUE/HG	TSSOP-16	3232C	REEL	2500pcs/reel
MAX3232EPE/HG	DIP-16	MAX3232E	TUBE	1000pcs/box
MAX3232ESE/HG	SOP-16	MAX3232E	REEL	2500pcs/reel
MAX3232EUE/HG	TSSOP-16	3232E	REEL	2500pcs/reel

Description

The MAX3232E is a 3.3V powered EIA/TIA-232 and V.28/V.24 communication interface with low power requirements, high data-rate capabilities. MAX3232E has a proprietary low dropout transmitter output stage providing true RS-232 performance from 3.3V to 5.5V supplies. The device requires only four small 0.1 μ F standard external capacitors for operations from 3.3V supply.

The MAX3232E has two receivers and two drivers. The device is guaranteed to run at data rates of 120Kbps while maintaining RS-232 output levels. Typical applications are Notebook, Subnotebook and Palmtop Computers, Battery Powered Equipment, Hand-Held Equipment, Peripherals and Printers.

Pin Configuration

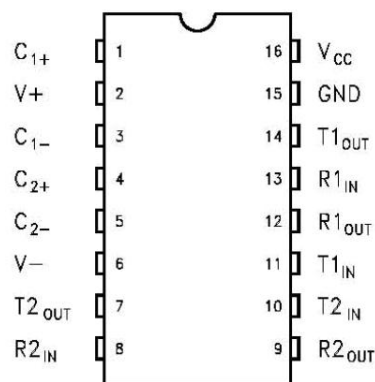

DIP-16/SOP-16/TSSOP-16

Pin Description

PIN N°	SYMBOL	NAME AND FUNCTION
1	C1+	Positive Terminal for the first Charge Pump Capacitor
2	V+	Doubled Voltage Terminal
3	C1-	Negative Terminal for the first Charge Pump Capacitor
4	C2+	Positive Terminal for the second Charge Pump Capacitor
5	C2-	Negative Terminal for the second Charge Pump Capacitor
6	V-	Inverted Voltage Terminal
7	T2OUT	Second Transmitter Output Voltage
8	R2IN	Second Receiver Input Voltage
9	R2OUT	Second Receiver Output Voltage
10	T2IN	Second Transmitter Input Voltage
11	T1IN	First Transmitter Input Voltage
12	R1OUT	First Receiver Output Voltage
13	R1IN	First Receiver Input Voltage
14	T1OUT	First Transmitter Output Voltage
15	GND	Ground
16	V _{CC}	Supply Voltage

Absolute Maximum Rating

Symbol	Parameter	Value	Unit	
V _{CC}	Supply Voltage	-0.3 to 6	V	
V+	Doubled Voltage Terminal	(V _{CC} - 0.3) to 7	V	
V-	Inverted Voltage Terminal	0.3 to -7	V	
V ₊ + V ₋		13	V	
T _{IN}	Transmitter Input Voltage Range	-0.3 to 6	V	
R _{IN}	Receiver Input Voltage Range	± 25	V	
T _{OUT}	Transmitter Output Voltage Range	± 13.2	V	
R _{OUT}	Receiver Output Voltage Range	-0.3 to (V _{CC} + 0.3)	V	
T _a	Operating Temperature	MAX3232C	0 to 70	°C
		MAX3232E	-40 to 85	°C
T _s	Storage Temperature	-60 to 150	°C	
T _L	Lead Temperature (Soldering, 10 seconds)	260	°C	
t _{SHORT}	Transmitter Output Short to GND Time	Continuous		

* Stresses beyond those listed under “absolute maximum ratings” may cause permanent damage to the device. These are stress ratings only and functional operation of the device at these or any other conditions beyond those indicated under “recommended operating conditions” is not implied. Exposure to absolute-maximum-rated conditions for extended periods may affect device reliability. V₊ and V₋ can have a maximum magnitude of +7V, but their absolute addition cannot exceed 13 V.

Electrical Characteristics

(C₁ - C₄ = 0.1μF, V_{CC} = 3.3V to 5.5V, T_A = -40 to 85°C, unless otherwise specified. Typical values are referred to T_A = 25°C)

Symbol	Parameter	Test Conditions	Min.	Typ.	Max.	Unit
I _{SUPPLY}	VCC Power Supply Current	No Load V _{CC} = 3.3V ±10% T _A = 25°C		2.5	5	mA
		No Load V _{CC} = 5V ±10% T _A = 25°C		6	10	mA

Logic Input Electrical Characteristics

(C₁ - C₄ = 0.1μF, V_{CC} = 3.3V to 5.5V, T_A = -40 to 85°C, unless otherwise specified. Typical values are referred to T_A = 25°C)

Symbol	Parameter	Test Conditions	Min.	Typ.	Max.	Unit
V _{TIL}	Input Logic Threshold Low	T-IN (Note 1)			0.8	V
V _{TIH}	Input Logic Threshold High	V _{CC} = 3.3V	2			V
		V _{CC} = 5V	2.4			V
I _{IL}	Input Leakage Current	T-IN		± 0.01	± 1	μA

Note1: Transmitter input hysteresis is typically 250mV

Transmitter Electrical Characteristics

(C₁ - C₄ = 0.1μF tested at V_{CC} = 3.3V to 5.5V, T_A = -40 to 85°C, unless otherwise specified. Typical values are referred to T_A = 25°C)

Symbol	Parameter	Test Conditions	Min.	Typ.	Max.	Unit	
V _{TOUT}	Output Voltage Swing	All Transmitter outputs are loaded with 3KΩ to GND	V _{CC} = 5.0V	± 5	± 5.4		V
			V _{CC} = 3.3V	± 3.5	± 4.0		V
R _{TOUT}	Transmitter Output Resistance	V _{CC} = V ₊ = V ₋ = 0V V _{OUT} = ± 2V	300	10M		Ω	
I _{TSC}	Output Short Circuit Current	V _{CC} = 3.3V to 5V V _{OUT} = 0V			± 60	mA	

Receiver Electrical Characteristics

(C₁ - C₄ = 0.1μF tested at V_{CC} = 3.3V to 5.5V, T_A = -40 to 85°C, unless otherwise specified. Typical values are referred to T_A = 25°C)

Symbol	Parameter	Test Conditions	Min.	Typ.	Max.	Unit
V _{RIN}	Receiver Input Voltage Operating Range		-25		25	V
V _{RIL}	RS-232 Input Threshold Low	T _A = 25°C V _{CC} = 3.3V	0.6	1.2		V
		T _A = 25°C V _{CC} = 5V	0.8	1.5		V
V _{RIH}	RS-232 Input Threshold High	T _A = 25°C V _{CC} = 3.3V		1.5	2.4	V
		T _A = 25°C V _{CC} = 5V		1.8	2.4	V
V _{RIHYS}	Input Hysteresis			0.3		V
R _{RIN}	Input Resistance	T _A = 25°C	3	5	7	kΩ
V _{ROL}	TTL/CMOS Output Voltage Low	I _{OUT} = 1.6mA V _{CC} = 3.3V			0.4	V
		I _{OUT} = 3.2mA V _{CC} = 5.5V				
V _{ROH}	TTL/CMOS Output Voltage High	I _{OUT} = -0.5mA V _{CC} = 3.3V	V _{CC} -0.6	V _{CC} -0.1		V
		I _{OUT} = -1mA V _{CC} = 5.5V				

Timing Characteristics

(C₁ - C₄ = 0.1μF, V_{CC} = 3.3V to 5.5V, T_A = -40 to 85°C, unless otherwise specified. Typical values are referred to T_A = 25°C)

Symbol	Parameter	Test Conditions	Min.	Typ.	Max.	Unit
D _R	Data Transfer Rate	C _{L2} = 1000pF R _L = 3KΩ one transmitter switching V _{CC} =3.3V			120	Kbps
t _{PHLR} t _{PLHR}	Propagation Delay Input to Output	R _{XIN} = R _{XOUT} C _L = 150pF		4.0	9.7	μs
t _{PHLT} t _{PLHT}	Propagation Delay Input to Output	R _L = 3KΩ C _L = 2500pF		2.0	5.0	μs
t _{PHLR} - t _{PLHR}	Receiver Propagation Delay Difference			300		ns
t _{PHLT} - t _{PLHT}	Transmitter Propagation Delay Difference			300		ns
S _{RT}	Transition Slew Rate	T _A = 25°C R _L = 3KΩ to 7KΩ V _{CC} =3.3V measured from +3V to -3V or -3V to +3V C _L = 150pF to 1000pF	3		30	V/μs

Transmitter Skew is measured at the transmitter zero cross points

Application Circuits

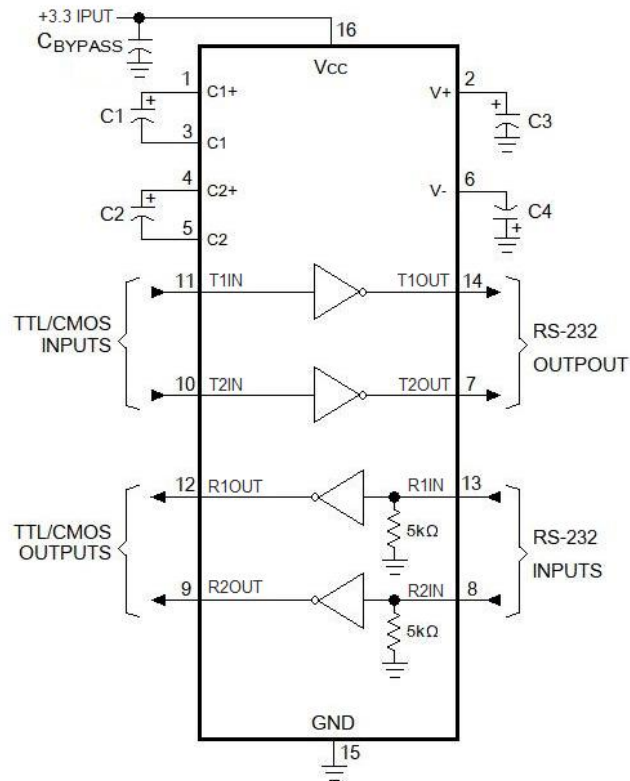

Capacitance Value (μf)

V _{CC}	C1	C2	C3	C4	Cbypass
3.0 to 5.5	1.0	1.0	1.0	1.0	1.0

Typical Operating Characteristics

(V_{CC} = +3.3V, 120kbps data rate, 0.1 μf capacitors, all transmitters loaded with 3k Ω , T_A = +25°C, unless otherwise noted.)

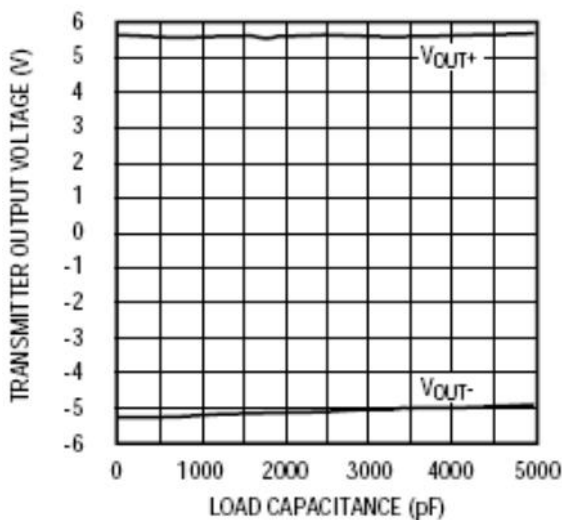

TRANSMITTER OUTPUT VOLTAGE
vs. LOAD CAPACITANCE

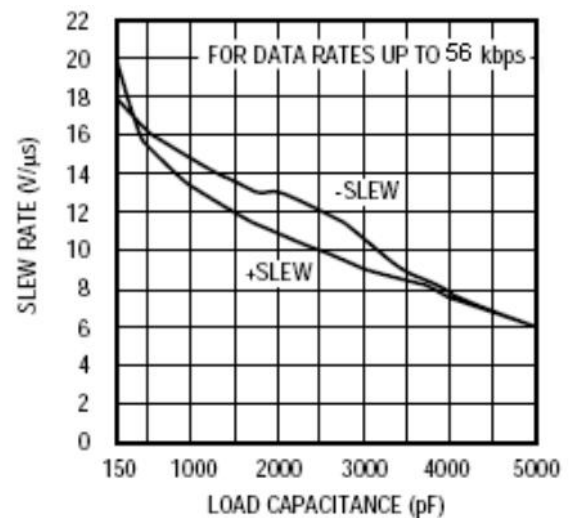

SLEW RATE
vs. LOAD CAPACITANCE

ESD Protection

The MAX3232E incorporates ruggedized ESD cells on all driver output and receiver input pins. The ESD structure is for rugged applications and environments sensitive to electro-static discharges and associated transients. The ESD tolerance is at least $\pm 15\text{kV}$ without damage or latch-up.

There are different methods of ESD testing applied:

- a) MIL-STD-883, Method 3015.7
- b) IEC1000-4-2 Air-Discharge

The Human Body Model has been the generally accepted ESD testing method for semiconductors. This method is also specified in MIL-STD- 883, Method 3015.7 for ESD testing. The premise of this ESD test is to simulate the human body's potential to store electro-static energy and discharge it to an integrated circuit. The simulation is performed by using a test model as shown in Figure 1. This method will test the IC's capability to withstand an ESD transient during normal handling such as in manufacturing areas where the ICs tend to be handled frequently.

The IEC-1000-4-2, formerly IEC801-2, is generally used for testing ESD on equipment and systems. For system manufacturers, they must guarantee a certain amount of ESD protection since the system itself is exposed to the outside environment and human presence. The premise with IEC1000-4-2 is that the system is required to withstand an amount of static electricity when ESD is applied to points and surfaces of the equipment that are accessible to personnel during normal usage. The transceiver IC receives most of the ESD current when the ESD source is applied to the connector pins. The test circuit for IEC1000-4-2 is shown on Figure 2. There are two methods within IEC1000-4-2, the Air Discharge method and the Contact Discharge method.

With the Air Discharge Method, an ESD voltage is applied to the equipment under test (EUT) through air. This simulates an electrically charged person ready to connect a cable onto the rear of the system only to find an unpleasant zap just before the person touches the back panel. The high energy potential on the person discharges through an arcing path to the rear panel of the system before he or she even touches the system. This energy, whether discharged directly or through air, is predominantly a function of the discharge current rather than the discharge voltage. Variables with an air discharge such as approach speed of the object carrying the ESD potential to the system and humidity will tend to change the discharge current. For example, the rise time of the discharge current varies with the approach speed.

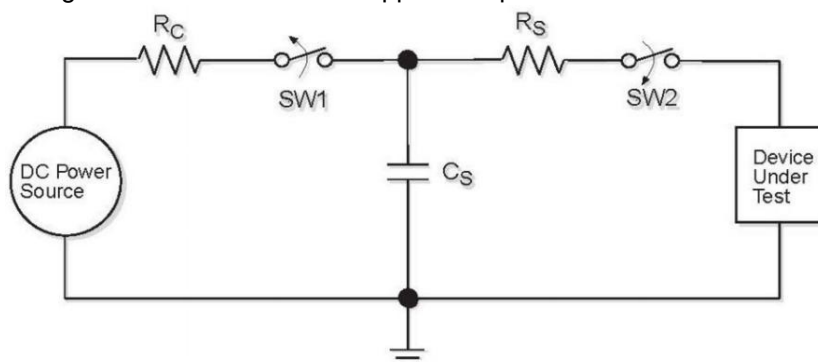

Fig. 1 ESD Test Circuit for Human Body Model

The Contact Discharge Method applies the ESD current directly to the EUT. This method was devised to reduce the unpredictability of the ESD arc. The discharge current rise time is constant since the energy is directly transferred without the air-gap arc. In situations such as hand held systems, the ESD charge can be directly discharged to the equipment from a person already holding the equipment. The current is transferred on to the keypad or the serial port of the equipment directly and then travels through the PCB and finally to the IC.

The circuit models in Figures 1 and 2 represent the typical ESD testing circuits used for these methods. The CS is initially charged with the DC power supply when the first switch (SW1) is on. Now that the capacitor is charged, the second switch (SW2) is on while SW1 switches off. The voltage stored in the capacitor is then applied through RS, the current limiting resistor, onto the device under test (DUT). In ESD tests, the SW2 switch is pulsed so that the device under test receives a duration of voltage.

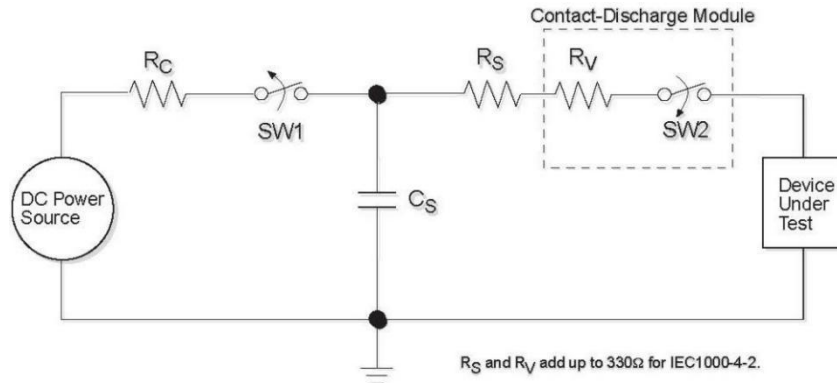

Fig. 2. ESD Test Circuit for IEC1000-4-2

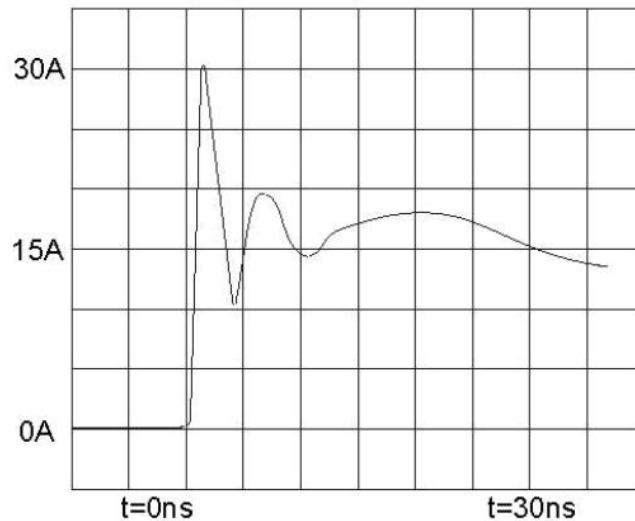

Fig. 3. ESD Test Waveform for IEC1000-4-2

For the Human Body Model, the current limiting resistor (R_s) and the source capacitor (C_s) are $1.5k\Omega$ and $100pF$, respectively. For IEC-1000-4-2, the current limiting resistor (R_s) and the source capacitor (C_s) are 330Ω and $150pF$, respectively. The higher C_s value and lower R_s value in the IEC1000-4-2 model are more stringent than the Human Body Model. The larger storage capacitor injects a higher voltage to the test point when SW2 is switched on. The lower current limiting resistor increases the current charge onto the test point.

Device Pin Tested	IEC1000-4-2	
	Air Discharge	Level
Driver Outputs Receiver Inputs	$\pm 15kV$	4
	$\pm 15kV$	4

Physical Dimensions

DIP-16

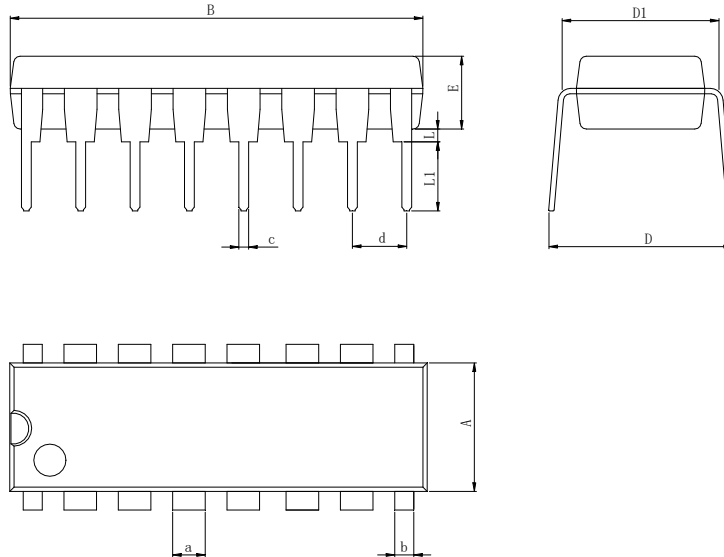

Dimensions In Millimeters(DIP-16)

Symbol:	A	B	D	D1	E	L	L1	a	b	c	d
Min:	6.10	18.94	8.10	7.42	3.10	0.50	3.00	1.50	0.85	0.40	2.54 BSC
Max:	6.68	19.56	10.9	7.82	3.55	0.70	3.60	1.55	0.90	0.50	

SOP-16

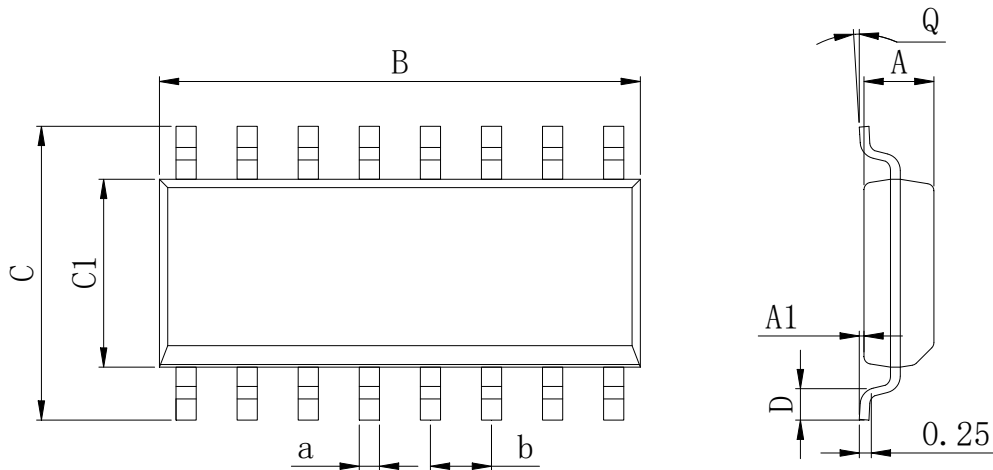

Dimensions In Millimeters(SOP-16)

Symbol:	A	A1	B	C	C1	D	Q	a	b
Min:	1.35	0.05	9.80	5.80	3.80	0.40	0°	0.35	1.27 BSC
Max:	1.55	0.20	10.0	6.20	4.00	0.80	8°	0.45	

Physical Dimensions

TSSOP-16

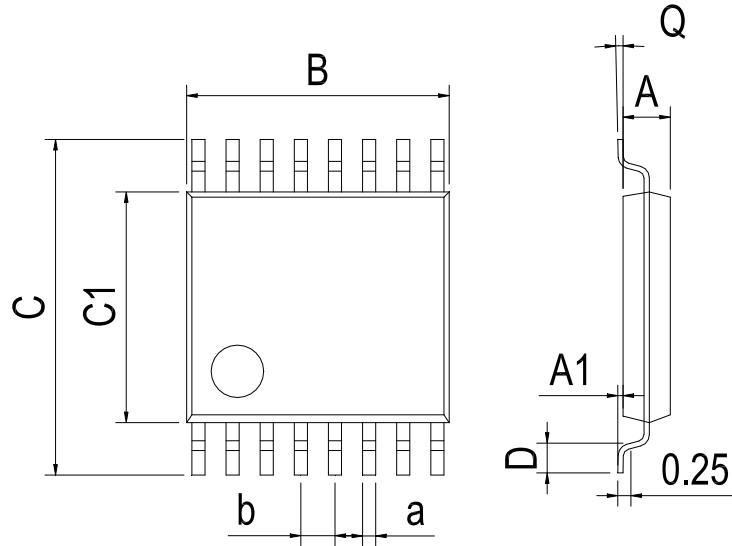

Dimensions In Millimeters(TSSOP-16)									
Symbol:	A	A1	B	C	C1	D	Q	a	b
Min:	0.85	0.05	4.90	6.20	4.30	0.40	0°	0.20	0.65 BSC
Max:	0.95	0.20	5.10	6.60	4.50	0.80	8°	0.25	

Revision History

REVISION NUMBER	DATE	REVISION	PAGE
V1.0	2014-8	New	1-12
V1.1	2018-10	Document Reformatting	1-12
V1.2	2024-11	Update Lead Temperature	3

IMPORTANT STATEMENT:

Huaguan Semiconductor reserves the right to change its products and services without notice. Before ordering, the customer shall obtain the latest relevant information and verify whether the information is up to date and complete. Huaguan Semiconductor does not assume any responsibility or obligation for the altered documents.

Customers are responsible for complying with safety standards and taking safety measures when using Huaguan Semiconductor products for system design and machine manufacturing. You will bear all the following responsibilities: Select the appropriate Huaguan Semiconductor products for your application; Design, validate and test your application; Ensure that your application meets the appropriate standards and any other safety, security or other requirements. To avoid the occurrence of potential risks that may lead to personal injury or property loss.

Huaguan Semiconductor products have not been approved for applications in life support, military, aerospace and other fields, and Huaguan Semiconductor will not bear the consequences caused by the application of products in these fields. All problems, responsibilities and losses arising from the user's use beyond the applicable area of the product shall be borne by the user and have nothing to do with Huaguan Semiconductor, and the user shall not claim any compensation liability against Huaguan Semiconductor by the terms of this Agreement.

The technical and reliability data (including data sheets), design resources (including reference designs), application or other design suggestions, network tools, safety information and other resources provided for the performance of semiconductor products produced by Huaguan Semiconductor are not guaranteed to be free from defects and no warranty, express or implied, is made. The use of testing and other quality control technologies is limited to the quality assurance scope of Huaguan Semiconductor. Not all parameters of each device need to be tested.

The documentation of Huaguan Semiconductor authorizes you to use these resources only for developing the application of the product described in this document. You have no right to use any other Huaguan Semiconductor intellectual property rights or any third party intellectual property rights. It is strictly forbidden to make other copies or displays of these resources. You should fully compensate Huaguan Semiconductor and its agents for any claims, damages, costs, losses and debts caused by the use of these resources. Huaguan Semiconductor accepts no liability for any loss or damage caused by infringement.