

## Features

- Output Adjustable between 1.2V and 37V
- Output current up to 1.5A
- Internal Thermal Overload Protection
- internal thermal Overload protection
- Output transistor safe area compensation

## Applications

- HVAC Systems
- SMPS Post Regulation
- Test and Measurement Equipment
- Industrial Power Supplies

## PIN CONFIGURATION

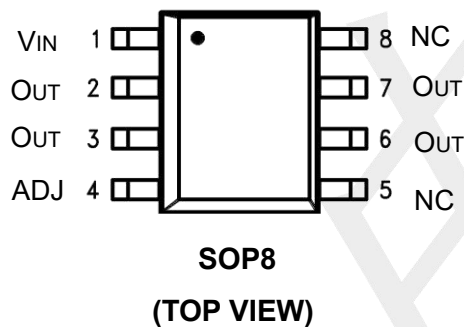

## Marking

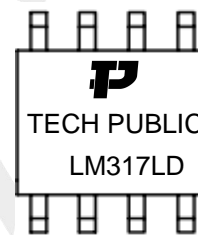

Pin Number	Pin Name	Pin Function
<b>SOP8</b>		
4	ADJ	Adjust pin
1	VIN	Input of Supply Voltage
2,3,6,7	VOUT	Output of the Regulator
5,8	NC	No connection

## Absolute Maximum Ratings

over operating free-air temperature range (unless otherwise noted)

SYMBOL	PARAMETER	RATINGS	UNIT
$V_i - V_o$	Input-Output Voltage Differential	40	V
$P_D$	Power Dissipation	Internally Limited	W
$T_J$	Operating Junction Temperature Range	+125	°C
$T_{stg}$	Storage temperature range	-65 ~ +150	°C
$T_{OPR}$	Operating Temperature	-40 ~ +85	°C

## THERMAL DATA

PARAMETER	SYMBOL	RATINGS	UNIT
Junction to Ambient	$\theta_{JA}$	111.3	°C/W
Junction to Case	$\theta_{JC}$	56.1	°C/W

## BLOCK DIAGRAM

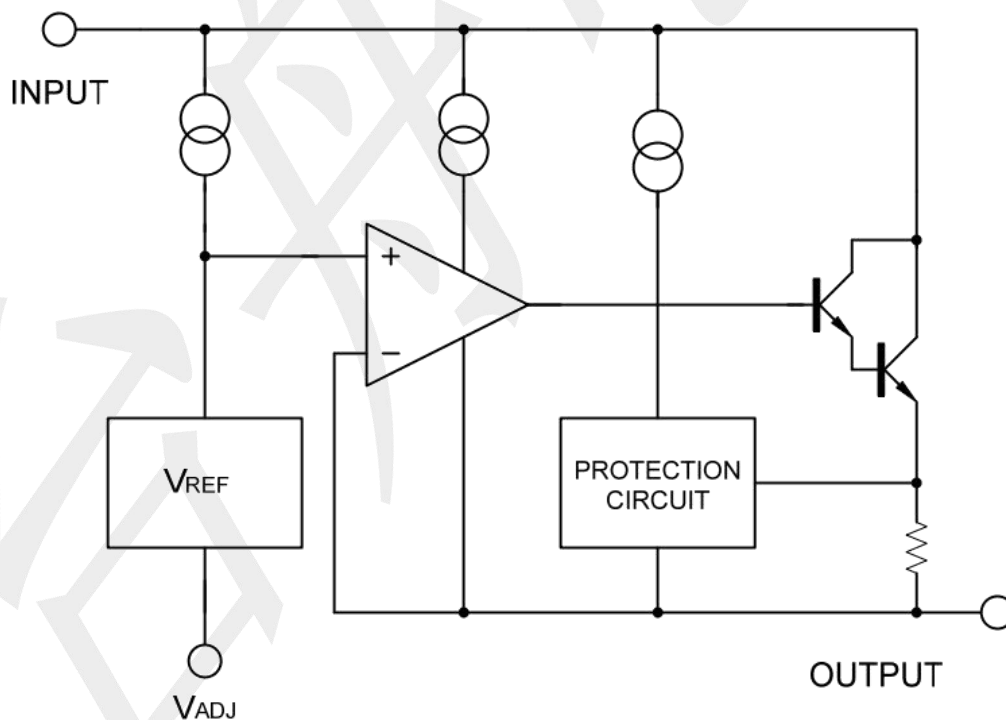

### Electrical Characteristics (TA=25°C, unless otherwise specified)

PARAMETER	SYMBOL	TEST Conditions	MIN	TYP	MAX	UNIT	
Line Regulation (Note 1)	$\Delta V_{OUT} / V_{OUT}$	$T_A = +25^\circ\text{C}, 3.0\text{V} \leq  V_I - V_O  \leq 40\text{V}$	--	0.01	0.04	%/V	
Load Regulation (Note 1)	$\Delta V_{OUT}$	$T_A = +25^\circ\text{C}, 10\text{mA} \leq I_O \leq 1.5\text{A}$	$ V_O  \leq 5.0\text{V}$	--	5	25	mV
			$ V_O  \geq 5.0\text{V}$	--	0.1	0.5	%
Adjustment Pin Current	$I_{ADJ}$		--	50	100	$\mu\text{A}$	
Adjustment Pin Current Change	$\Delta I_{ADJ}$	$3.0\text{V} \leq  V_I - V_O  \leq 40\text{V}, 10\text{mA} \leq I_L \leq 1.5\text{A}, P_D \leq P_{MAX}, T_A = +25^\circ\text{C}$	--	2.0	5.0	$\mu\text{A}$	
Reference Voltage	$V_{REF}$	$T_A = +25^\circ\text{C}, 3.0\text{V} \leq  V_I - V_O  \leq 40\text{V}$	1.215	1.250	1.285	V	
		$10\text{mA} \leq I_O \leq 1.5\text{A}, P_D \leq P_{MAX}, T_J = T_{LOW} \text{ to } T_{HIGH}$	1.20	1.25	1.30	V	
Temperature Stability	$T_S$	$T_{LOW} \leq T_J \leq T_{HIGH}$	--	0.7	--	% $V_O$	
Minimum Load Current to Maintain Regulation	$I_{LMIN}$	$ V_I - V_O  \leq 10\text{V}$	--	1.5	6.0	mA	
		$ V_I - V_O  \leq 40\text{V}$	--	2.5	10	mA	
Maximum Output Current	$I_{MAX}$	$ V_I - V_O  \leq 15\text{V}, P_D \leq P_{MAX}$	1.5	2.2	--	A	
		$ V_I - V_O  \leq 40\text{V}, P_D \leq P_{MAX}, T_J = +25^\circ\text{C}$	0.3	0.4	--	A	
RMS Noise	N	% of $V_O, T_A = +25^\circ\text{C}, 10\text{Hz} \leq f \leq 10\text{kHz}$	--	0.003	--	% $V_O$	
Ripple Rejection	RR	$V_O = -10\text{V}, f = 120\text{Hz}$ (Note 2)	Without $C_{ADJ}$	--	65	--	dB
			$C_{ADJ} = 10\mu\text{F}$	66	80	--	dB
Long-Term Stability	S	$T_J = T_{HIGH}$ (Note 4), $T_A = +25^\circ\text{C}$ for Endpoint Measurements		0.3	1.0	%/1.0k Hrs.	
Thermal Regulation		$T_A = +25^\circ\text{C}$ (Note 3), 10ms Pulse		0.003	0.4	% $V_O/W$	

Notes: 1. Load and line regulation are specified at constant junction temperature. Change in  $V_O$  because of heating effects is covered under the Thermal Regulation specification. Pulse testing with a low duty cycle is used.

2.  $C_{ADJ}$ , when used, is connected between the adjustment pin and ground.

3. Power dissipation within an IC voltage regulator produces a temperature gradient on the die, affecting individual IC components on the die. These effects can be minimized by proper integrated circuit design and layout techniques. Thermal Regulation is the effect of these temperature gradients on the output voltage and is expressed in percentage of output change per watt of power change in a specified time.

4. Since Long Term Stability cannot be measured on each device before shipment, this specification is an engineering estimate of average stability from lot to lot.

## Typical Application Circuit

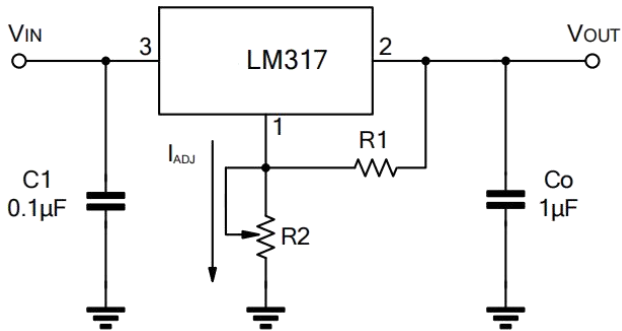

$$V_{OUT} = 1.25V \times (1 + R2/R1) + I_{ADJ} \times R2$$

C1 is required when regulator is located an appreciated distance from power supply. Co is needed to improve transient response.

**Programmable voltage regulator**

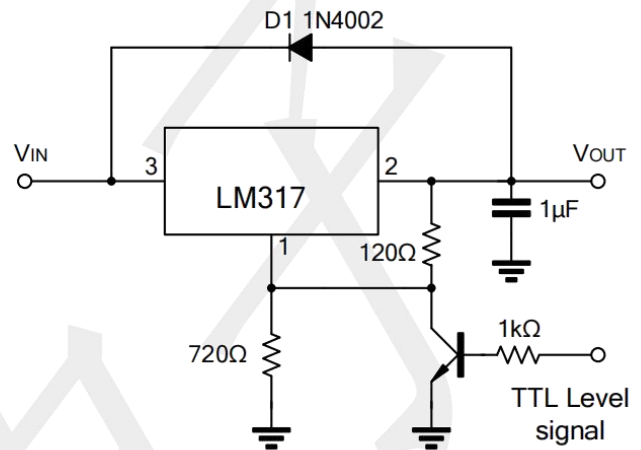

**Regulator with On-off control**

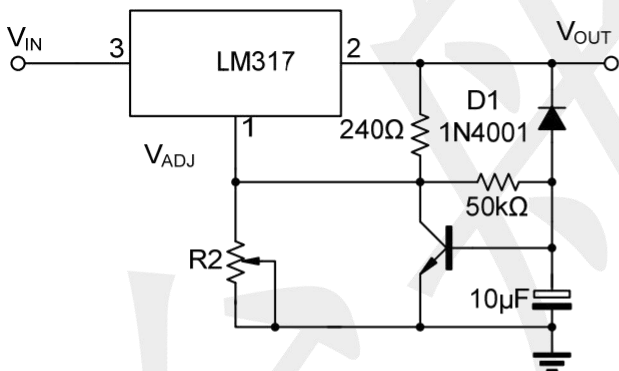

**Soft Start Application**

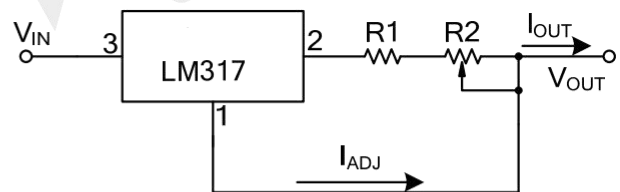

$$I_{O(MAX)} = \left( \frac{V_{REF}}{R1} \right) + I_{ADJ} = \frac{1.25V}{R1}$$

$$I_{O(MIN)} = \left( \frac{V_{REF}}{R1+R2} \right) + I_{ADJ} = \frac{1.25V}{R1+R2}$$

**Constant Current Application**

## Package Outline Dimensions (unit: mm)

### SOP8

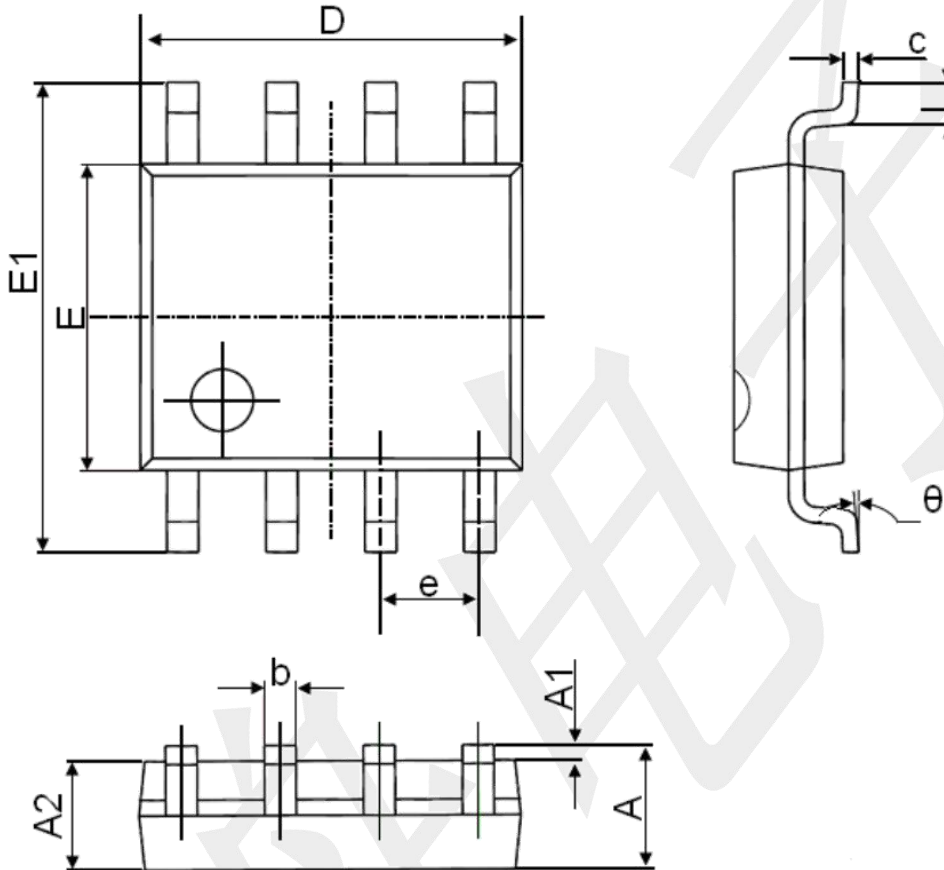

Symbol	Dimensions In Millimeters		Dimensions In Inches	
	Min.	Max.	Min.	Max.
A	1.350	1.750	0.053	0.069
A1	0.100	0.250	0.004	0.010
A2	1.350	1.550	0.053	0.061
b	0.330	0.510	0.013	0.020
c	0.170	0.250	0.006	0.010
D	4.700	5.100	0.185	0.200
E	3.800	4.000	0.150	0.157
E1	5.800	6.200	0.228	0.244
e	1.270(BSC)		0.050(BSC)	
L	0.400	1.270	0.016	0.050
θ	0°	8°	0°	8°