

**MATERIAL:**

HOUSING: LCP,UL94V-0,BLACK.  
 TERMINALS BRACKET: LCP,UL94V-0,BLACK.  
 SHIELD: C2680,T=0.20MM,NICKEL PLATING ON ALL AREA.  
 TERMINAL: PHOSPHOR BRONZE C5210,T=0.35MM,  
 6U" GOLD PLATING ON CONTACT AREA.

**MECHANICAL:**

DURABILITY: 750 CYCLES MIN.  
 MATING FORCE: 23N MAX.  
 OPERATING TEMPERATURE: -40°C~+85°C.  
 STORAGE TEMPERATURE: -40°C~+85°C.  
 ALL CRITICAL DIMENSIONS WITH "\*"

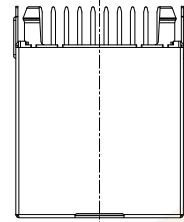

TOP VIEW

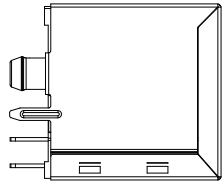

LEFT SIDE VIEW

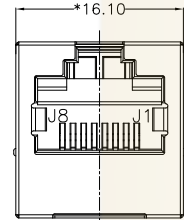

FRONT VIEW

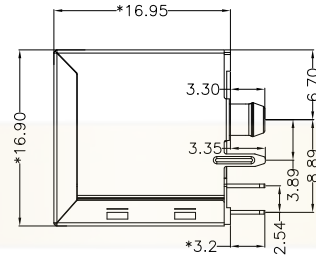

RIGHT SIDE VIEW

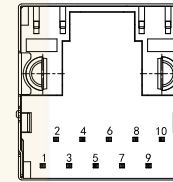

BACK VIEW

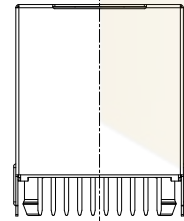

BOTTOM VIEW

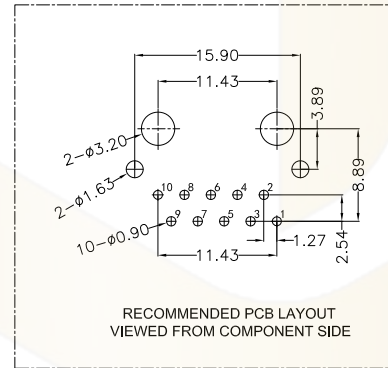

**Ordering Information**

HC 62 \* \* \*\* A- M911 - A

Type	LED Color	EMI	Ports	产品序号
☐ 卧式插片	☐ 绿灯	☐ 无弹	☐ 1-10口	
☐ 立式插片	☐ 黄灯 < 全彩插片 >	☐ 有弹	☐ 0-10口	
☐ 立式插片	☐ 绿灯 < 全彩插片 >	☐ 有弹	☐ 0-10口	
☐ 立式插片	☐ 绿灯 < 全彩插片 >	☐ 有弹	☐ 20-10口	.....

			GENERAL TOLERANCE		制图 DRAWING		深圳市华灿天禄电子有限公司 ShenzhenhuacantianluELECTRONICS CO., LTD				
			DIM	TOL	审核 CHECK		产品名称 TITLE		网络插座 (插件 无灯无弹 TAB-UP 1X1 10/100/1000BASE)	版本 REV.	A
			X.X	±0.30	批准 APPROVAL		产品料号 PART NO.		HC620601A-M911-A	单位 UNITS	mm
			X.XX	±0.20	比例 SCALE		材料 MATERIAL			页次 SHEET	1/4
			X.XXX	±0.10	投影 Projection						
序号 No.	变更内容 MODIFY CONTENT	日期 MODIFY DATE	Angle ±3.0°								

Suggested Panel Opening:

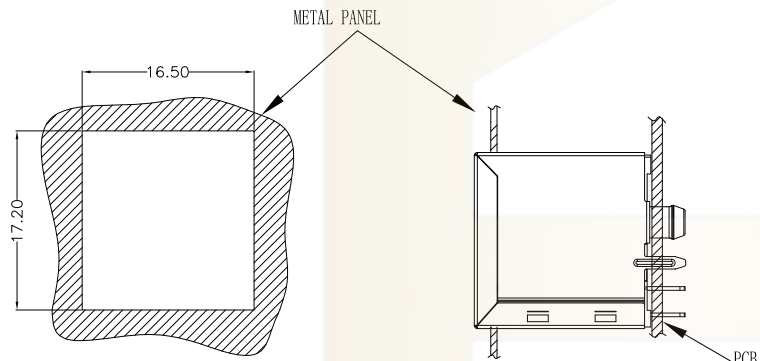

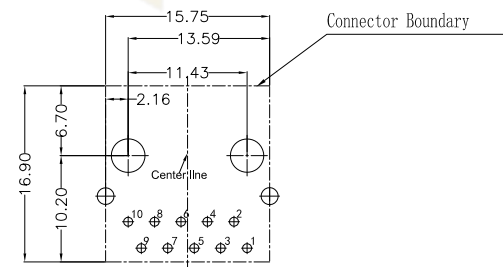

UNIT: mm / inch  
Tolerances:  $\pm 0.10 / 0.004$

Keep-Out Area (Component Side View):



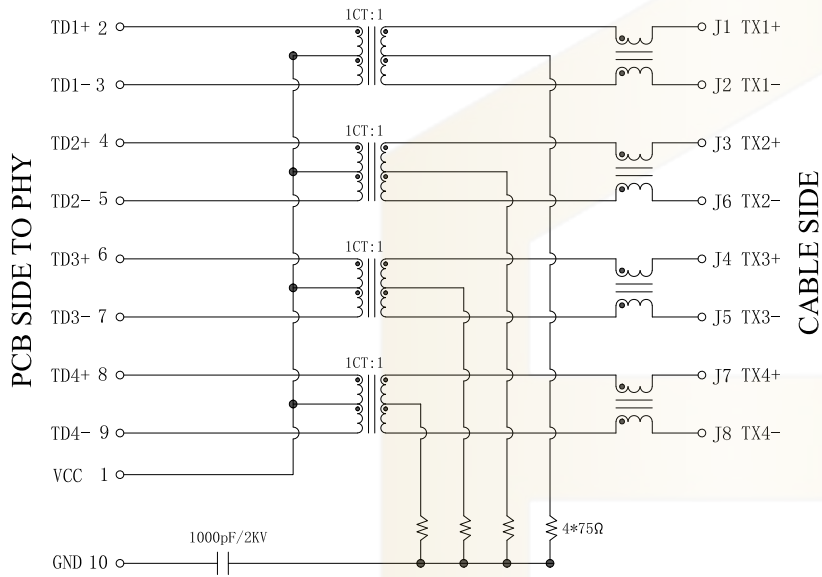

UNIT: mm / inch  
Tolerances:  $\pm 0.10 / 0.004$

			GENEAL TOLERANCE	制图 DRAWING	 深圳市华灿天禄电子有限公司 ShenzhenhuacantianluELECTRONICS CO., LTD			
			DIM TOL	审核 CHECK				
			X.X $\pm 0.30$	批准 APPROVAL	产品名称 TITLE	网络插座 (插件 无灯无弹) TAB-UP 1X1 10/100/1000BASE)	版本 REV.	A
1	初版发行		X.XX $\pm 0.20$	比例 SCALE	产品料号 PART NO.	HC620601A-M911-A	单位 UNITS	mm
序号 No.	变更内容 MODIFY CONTENT	日期 MODIFY DATE	X.XXX $\pm 0.10$	投影 Projection	材料 MATERIAL		页次 SHEET	2/4
			Angle $\pm 3.0^\circ$					



**Electrical:**



1. Turn ratio: 2~3: J1~J2=1CT:1CT(±2%).  
4~5: J3~J6=1CT:1CT(±2%).  
6~7: J4~J5=1CT:1CT(±2%).  
8~9: J7~J8=1CT:1CT(±2%).
2. OCL: 350uH Min. at 100KHz 100mV 8mA DC.
3. Insertion Loss: -1.0 dB Max 1~100MHz.
4. Return loss: -18dB Min 1~30MHz;  
-14dB Min 30~60MHz.  
-12dB Min 60~80MHz.  
-10dB Min 80~100MHz.
5. Cross talk: -40dB Min 1~30MHz;  
-35dB Min 30~60MHz;  
-30dB Min 60~100MHz;
6. CMR: -30dB Min 1~100MHz;
7. Hi-Pot: 2250V DC 6S 1mA PRI TO SEC

			GENE RL TOLERANCE	制 图 DRAWING	 深圳市华灿天禄电子有限公司 ShenzhenhuacantianluELECTRONICS CO., LTD				
			DIM TOL	审 核 CHECK	产品名称 TITLE		网络插座 (插件 无灯无弹 TAB-UP 1X1 10/100/1000BASE)	版 本 REV.	A
			X. X ±0.30	批 准 APPROVAL	产品料号 PART NO.		HC620601A-M911-A	单 位 UNITS	mm
1	初版发行		X. XX ±0.20	比 例 SCALE				页 次 SHEET	3/4
序号 No.	变更内容 MODIFY CONTENT	日期 MODIFY DATE	X. XXX ±0.10	投 影 Projection			材 料 MATERIAL		
			Angle ±3.0°						

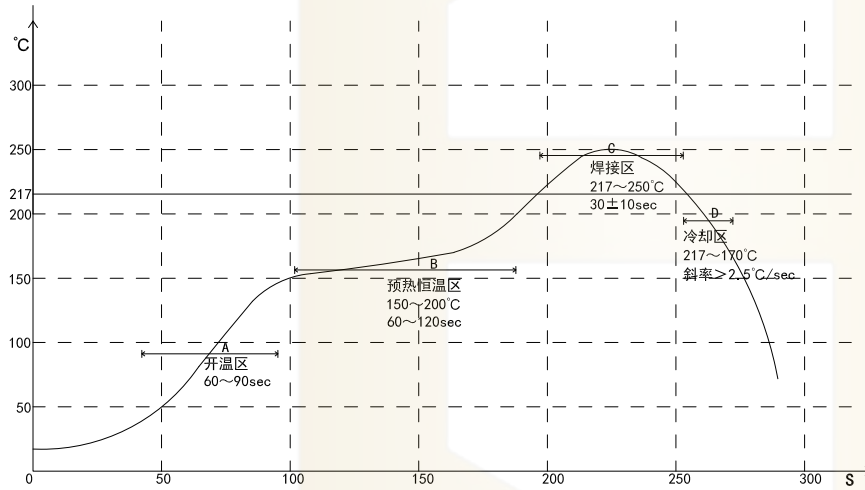
# PROFILE OF REFLOW SOLDERING



A. Temperature range of open  
 B. Preheat temperature zone  
 C. The welding zone  
 D. The cooling zone  
 Tip temperature: 265±5°C.  
 Tip temperature time: 30±10Sec.  
 Tip melting point of Sn96.5/Ag3/Cu0.5.

			GENERAL TOLERANCE	制图 DRAWING	 深圳市华灿天禄电子有限公司 ShenzhenhuacantianluELECTRONICS CO., LTD				
			DIM TOL	审核 CHECK		产品名称 TITLE	网络插座 (插件 无灯无弹 TAB-UP 1X1 10/100/1000BASE)	版本 REV.	A
			X. X ±0.30	批准 APPROVAL		产品料号 PART NO.	HC620601A-M911-A	单位 UNITS	mm
1	初版发行		X. XX ±0.20	比例 SCALE		材料 MATERIAL		页次 SHEET	4/4
序号 No.	变更内容 MODIFY CONTENT	日期 MODIFY DATE	X. XXX ±0.10	投影 Projection					
			Angle ±3.0°						