

# BZT52C2V4-BZT52C75

350mW, 5% Tolerance SMD Zener Diode

## FEATURES

- \*Small Signal Diode
- \*Wide zener voltage range selection : 2.4V to 75V
- \*VZ Tolerance Selection of  $\pm 5\%$
- \*Moisture sensitivity : Level  $\geq 3$  per JEDEC-STD-020A
- \*Pb free version and RoHS compliant

## MECHANICAL DATA

- \*High temperature soldering guaranteed: 260°C/10s
- \*Polarity : Indicated by cathode band
- \*Weight : 9.20 $\pm$ 0.5 mg

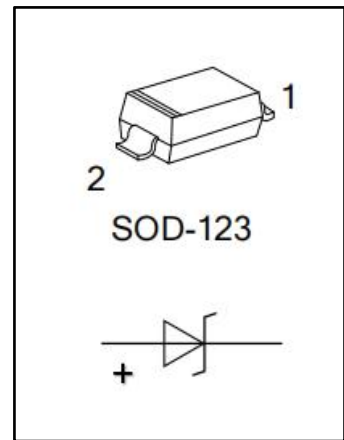

## MAXIMUM RATINGS AND ELECTRICAL CHARACTERISTICS

( Rating at 25°C ambient temperature unless otherwise specified. )

Type Number	Symbol	Value	Units
Power Dissipation	PD	350	mW
Forward Voltage IF=10mA	VF	0.9	V
Thermal Resistance (Junction to Ambient) (Note 1)	R $\theta$ JA	625	°C/W
Junction and Storage Temperature Range	TJ , TSTG	-55 to + 150	°C

Notes:1. Valid provided that electrodes are kept at ambient temperature

## ZENER I VS. V CHARACTERISTICS

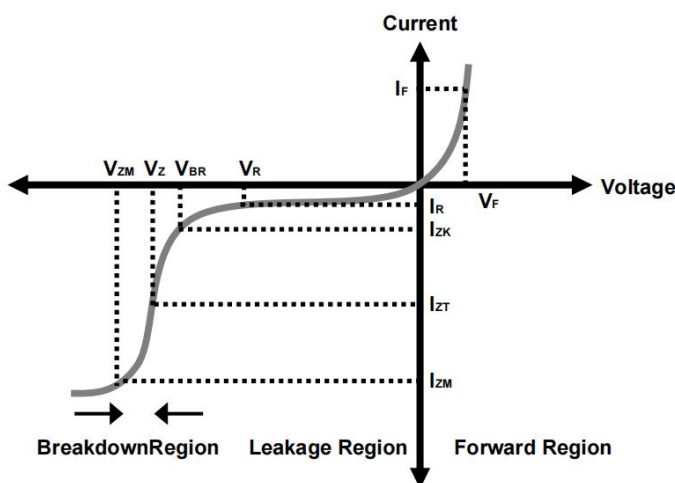

- V<sub>BR</sub>** : Voltage at I<sub>ZK</sub>
- I<sub>ZK</sub>** : Test current for voltage V<sub>BR</sub>
- Z<sub>ZK</sub>** : Dynamic impedance at I<sub>ZK</sub>
- I<sub>ZT</sub>** : Test current for voltage V<sub>Z</sub>
- V<sub>Z</sub>** : Voltage at current I<sub>ZT</sub>
- Z<sub>ZT</sub>** : Dynamic impedance at I<sub>ZT</sub>
- I<sub>ZM</sub>** : Maximum steady state current
- V<sub>ZM</sub>** : Voltage at I<sub>ZM</sub>



# BZT52C2V4-BZT52C75

350mW, 5% Tolerance SMD Zener Diode

## ■ ELECTRICAL CHARACTERISTICS (1)

Ta = 25°C unless otherwise noted

VF Forward Volatge = 0.9 V Maximum @ IF = 10mA for all part numbers

Part Number	Device Marking	VZ @ IZT (Volt)			IZT(mA)	ZZT @ IZT(Ω)		ZZK @ IZK(Ω)	IR @ VR(μA)Max	
		Min	Nom	Max		Max	IZK(mA)		Max	IR
BZT52C2V4	WX	2.28	2.40	2.52	5	100	1.0	600	50	1
BZT52C2V7	W1	2.57	2.70	2.84	5	100	1.0	600	20	1
BZT52C3V0	W2	2.85	3.00	3.15	5	95	1.0	600	10	1
BZT52C3V3	W3	3.14	3.30	3.47	5	95	1.0	600	5	1
BZT52C3V6	W4	3.42	3.60	3.78	5	90	1.0	600	5	1
BZT52C3V9	W5	3.71	3.90	4.10	5	90	1.0	600	3	1
BZT52C4V3	W6	4.09	4.30	4.52	5	90	1.0	600	3	1
BZT52C4V7	W7	4.47	4.70	4.94	5	80	1.0	500	3	2
BZT52C5V1	W8	4.85	5.10	5.36	5	60	1.0	480	2	2
BZT52C5V6	W9	5.32	5.60	5.88	5	40	1.0	400	1	2
BZT52C6V2	WA	5.89	6.20	6.51	5	10	1.0	150	3	4
BZT52C6V8	WB	6.46	6.80	7.14	5	15	1.0	80	2	4
BZT52C7V5	WC	7.13	7.50	7.88	5	15	1.0	80	1	5
BZT52C8V2	WD	7.79	8.20	8.61	5	15	1.0	80	0.7	5
BZT52C9V1	WE	8.65	9.10	9.56	5	15	1.0	100	0.5	6
BZT52C10	WF	9.50	10.00	10.50	5	20	1.0	150	0.2	7
BZT52C11	WG	10.45	11.00	11.55	5	20	1.0	150	0.1	8
BZT52C12	WH	11.40	12.00	12.60	5	25	1.0	150	0.1	8
BZT52C13	WI	12.35	13.00	13.65	5	30	1.0	170	0.1	8
BZT52C15	WJ	14.25	15.00	15.75	5	30	1.0	200	0.1	10.5
BZT52C16	WK	15.20	16.00	16.80	5	40	1.0	200	0.1	11.2
BZT52C18	WL	17.10	18.00	18.90	5	45	1.0	225	0.1	12.6
BZT52C20	WM	19.00	20.00	21.00	5	55	1.0	225	0.1	14.0
BZT52C22	WN	20.90	22.00	23.10	5	55	1.0	250	0.1	15.4
BZT52C24	WO	22.80	24.00	25.20	5	70	1.0	250	0.1	16.8

# BZT52C2V4-BZT52C75

350mW, 5% Tolerance SMD Zener Diode

## ■ ELECTRICAL CHARACTERISTICS (2)

Ta = 25°C unless otherwise noted

VF Forward Voltage = 0.9 V Maximum @ IF = 10mA for all part numbers

Part Number	Device Marking	VZ @ IZT (Volt)			IZT(mA)	ZZT @ IZT(Ω) Max	IZK(mA)	ZZK @ IZK(Ω) Max	IR @ VR(μA) Max	
		Min	Nom	Max					IR	VR(V)
BZT52C27	WP	25.65	27.00	28.35	5	80	0.5	300	0.1	18.9
BZT52C30	WQ	28.50	30.00	31.50	5	80	0.5	300	0.1	21.0
BZT52C33	WR	31.35	33.00	34.65	5	80	0.5	325	0.1	23.1
BZT52C36	WS	34.20	36.00	37.80	5	90	0.5	350	0.1	25.2
BZT52C39	WT	37.05	39.00	40.95	5	130	0.5	350	0.1	27.3
BZT52C43	WU	40.85	43.00	45.15	5	100	1.0	700	0.1	32.0
BZT52C47	WV	44.65	47.00	49.35	2	170	1.0	375	0.1	32.9
BZT52C51	WW	48.45	51.00	53.55	2	180	1.0	400	0.1	35.7
BZT52C56	Wd	53.20	56.00	58.80	2	200	0.5	425	0.1	39.2
BZT52C62	WY	58.90	62.00	65.10	2	215	0.5	450	0.1	43.4
BZT52C68	WZ	64.60	68.00	71.40	2	240	0.5	475	0.1	47.6
BZT52C75	Wb	71.25	75.00	78.75	2	255	0.5	500	0.1	52.5

### Notes:

- (1) The Zener Voltage (VZ) is tested under pulse condition of 10ms.
- (2) The device numbers listed have a standard tolerance on the nominal zener voltage of ±5%.
- (3) The Zener impedance is derived from the 60-cycle ac voltage, which results when an ac current having an rms value equal to 10% of the dc zener current (IZT or IZK) is superimposed to IZT or IZK.

## ■ MARKING

Type Code: Marking: WX--Wb (Please refer to the table above: **Device Marking**)



# BZT52C2V4-BZT52C75

350mW, 5% Tolerance SMD Zener Diode

## ■ RATING AND SHARACTERISTIC CURVES

FIG 1 Typical Forward Characteristics

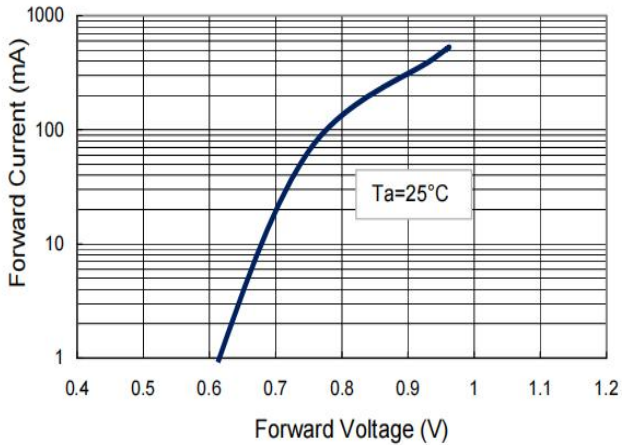

FIG 2 Zener Breakdown Characteristics

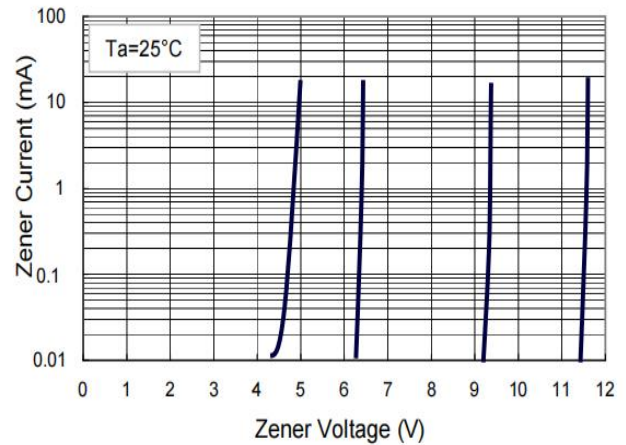

FIG 3 Zener Breakdown Characteristics

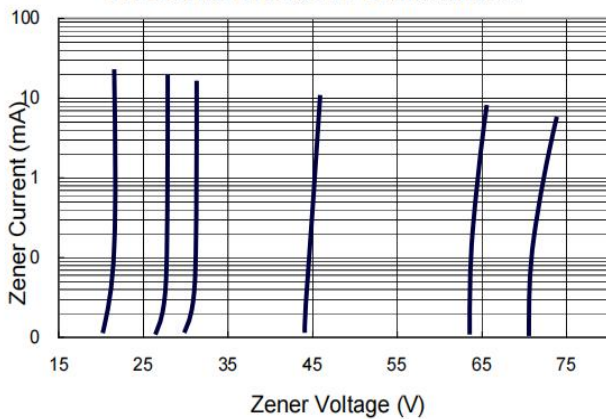

FIG 4 Admissible Power Dissipation Curve

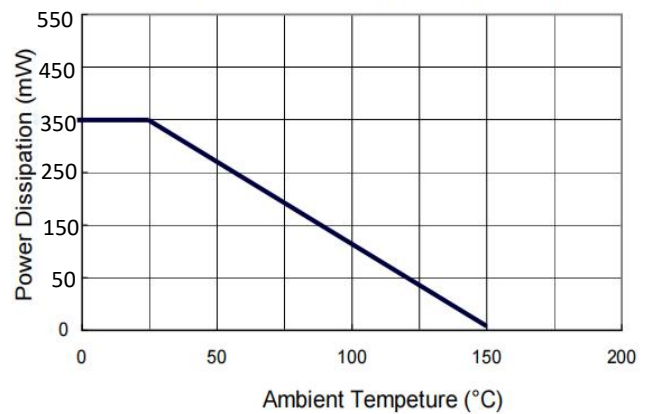

FIG 5 Typical Capacitance

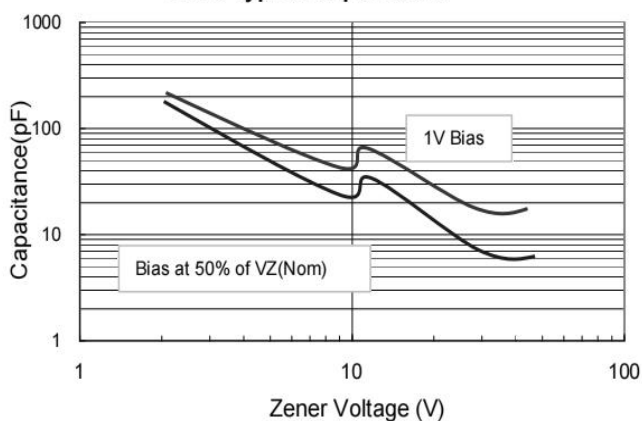
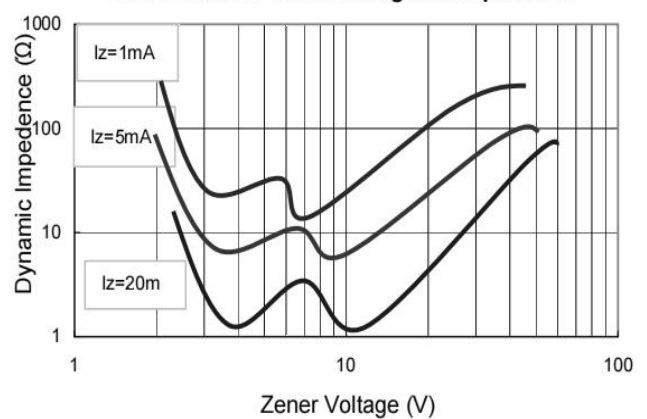

FIG 6 Effect of Zener Voltage on Impedance



# BZT52C2V4-BZT52C75

350mW, 5% Tolerance SMD Zener Diode

## SOD-123 PACKAGE OUTLINE DIMENSIONS

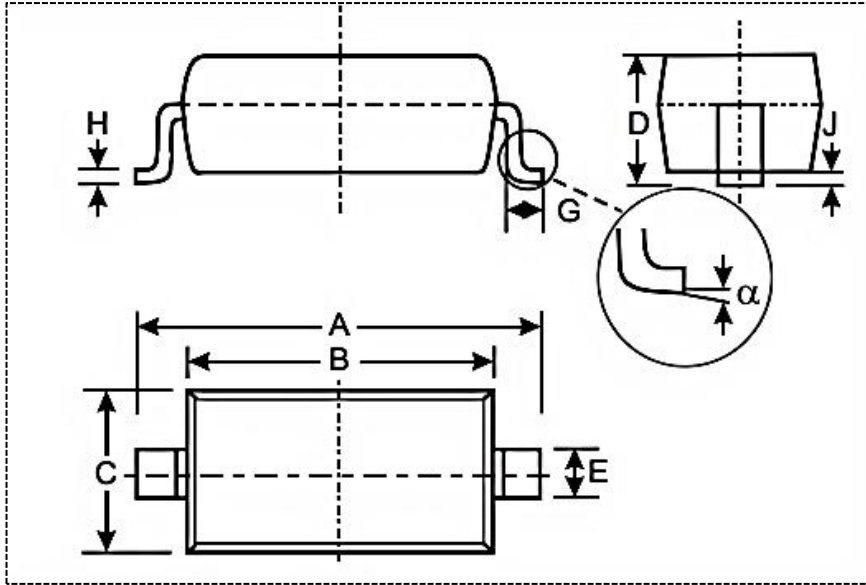

SOD-123		
Dim	Min	Max
A	3.55	3.85
B	2.60	2.80
C	1.50	1.70
D	1.06	1.25
E	0.45	0.65
G	0.25	-
H	0.09	0.15
J	0.01	0.1
$\alpha$	0°	8°
All Dimensions in mm		

## REEL PACKING

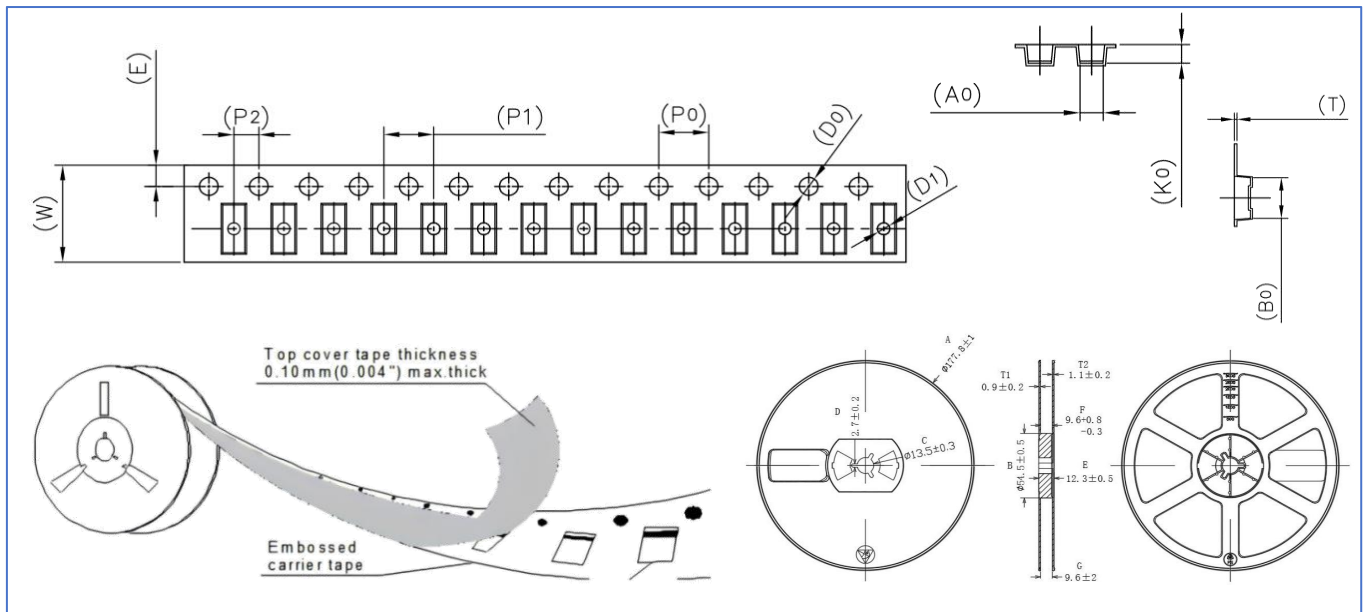

Dimensions are in millimeter

PKG TYPE	W	A0	B0	K0	E	P1	P0	P2	D0	D1	T
SOD-123	8.00	1.77	3.91	1.33	1.75	4.00	4.00	2.00	1.50	1.00	0.20
Reel Option	A	B	C	D	E	F	G	T1	T2	Q.TY PER REEL	
7" Dia	Φ177.8	Φ54.5	Φ13.5	2.7	12.3	9.6	9.6	0.9	1.1	3000PCS	