

2A 150KHz 42V Buck DC to DC Converter

Features

- Wide 4.5V to 42V Input Voltage Range
- 3.3V,5V,12V, and adjustable versions
- Output Adjustable from 1.23V to 37V
- Maximum Duty Cycle 100%
- Minimum Drop Out 1.5V
- Fixed 150KHz Switching Frequency
- 2A Constant Output Current Capability
- Internal Optimize Power Transistor
- High efficiency
- Excellent line and load regulation
- TTL shutdown capability
- ON/OFF pin with hysteresis function
- Built in thermal shutdown function
- Built in current limit function
- Built in second current limit function
- Available in SOP8L package

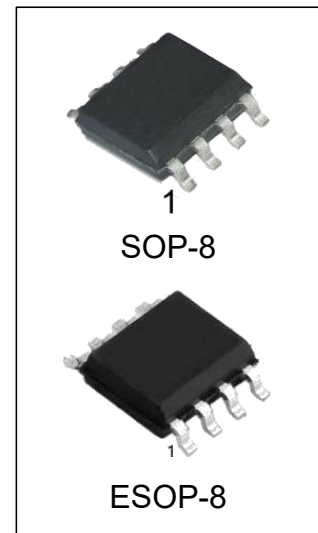

Ordering Information

DEVICE	Package Type	MARKING	Packing	Packing Qty
HG1509-3.3M/TR	SOP-8	HG1509-3.3,1509-3.3	REEL	2500pcs/reel
HG1509-5.0M/TR	SOP-8	HG1509-5.0,1509-5.0	REEL	2500pcs/reel
HG1509-12M/TR	SOP-8	HG1509-12,1509-12	REEL	2500pcs/reel
HG1509-ADJM/TR	SOP-8	HG1509-ADJ,1509-ADJ	REEL	2500pcs/reel
HG1509-3.3ME/TR	ESOP-8	HG1509-3.3,1509-3.3	REEL	2500pcs/reel
HG1509-5.0ME/TR	ESOP-8	HG1509-5.0,1509-5.0	REEL	2500pcs/reel
HG1509-12ME/TR	ESOP-8	HG1509-12,1509-12	REEL	2500pcs/reel
HG1509-ADJME/TR	ESOP-8	HG1509-ADJ,1509-ADJ	REEL	2500pcs/reel

General Description

The HG1509 is a 150 KHz fixed frequency PWM buck (step-down) DC/DC converter, capable of driving a 2A load with high efficiency, low ripple and excellent line and load regulation. Requiring a minimum number of external components, the regulator is simple to use and include internal frequency compensation and a fixed-frequency oscillator.

The PWM control circuit is able to adjust the duty ratio linearly from 0 to 100%. An enable function, an over current protection function is built inside. When second current limit function happens, the operation frequency will be reduced from 150KHz to 50KHz. An internal compensation block is built in to minimize external component count.

Applications

- LCD Monitor and LCD TV
- Digital Photo Frame
- Set-up Box
- ADSL Modem
- Telecom / Networking Equipment

Pin Configurations

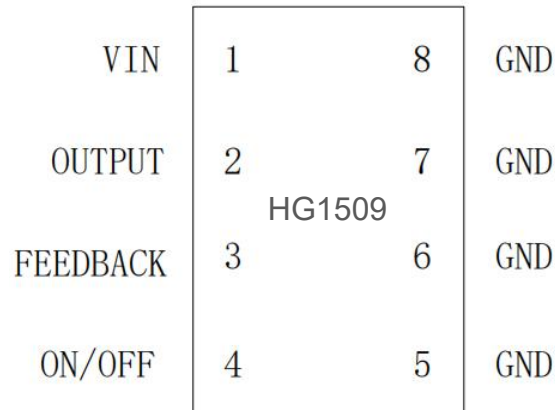

Figure1. Pin Configuration of HG1509 (Top View)

Table 1 Pin Description

Pin Number	Pin Name	Description
1	VIN	Supply Voltage Input Pin. HG1509 operates from a 4.5V to 42V DC voltage. Bypass Vin to GND with a suitably large capacitor to eliminate noise on the input.
2	OUTPUT	Power Switch Output Pin (SW). Output is the switch node that supplies power to the output.
5~8	GND	Ground Pin. Care must be taken in layout. This pin should be placed outside of the Schottky Diode to output capacitor ground path to prevent switching current spikes from inducing voltage noise into HG1509.
3	FEEDBACK	Feedback Pin (FB). Through an external resistor divider network, Feedback senses the output voltage and regulates it. The feedback threshold voltage is 1.23V.
4	ON/OFF	Enable Pin. Drive ON/OFF pin low to turn on the device, drive it high to turn it off. Floating is default low.

Function Block

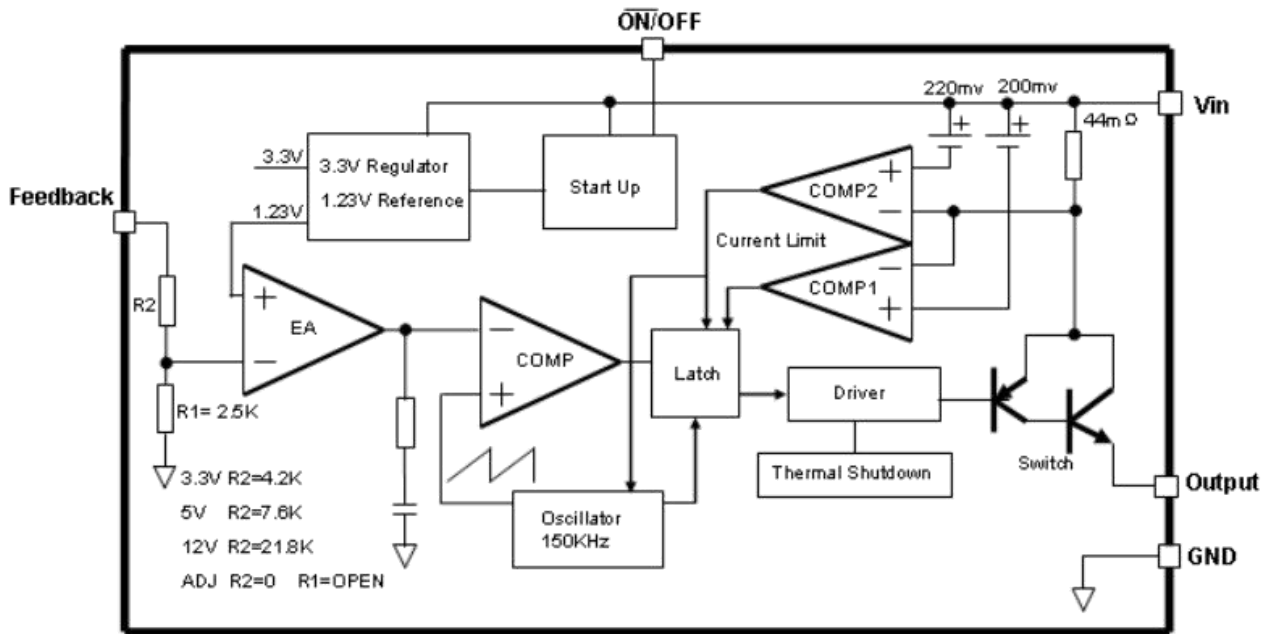

Figure 2. Function Block Diagram of HG1509

Typical Application Circuit

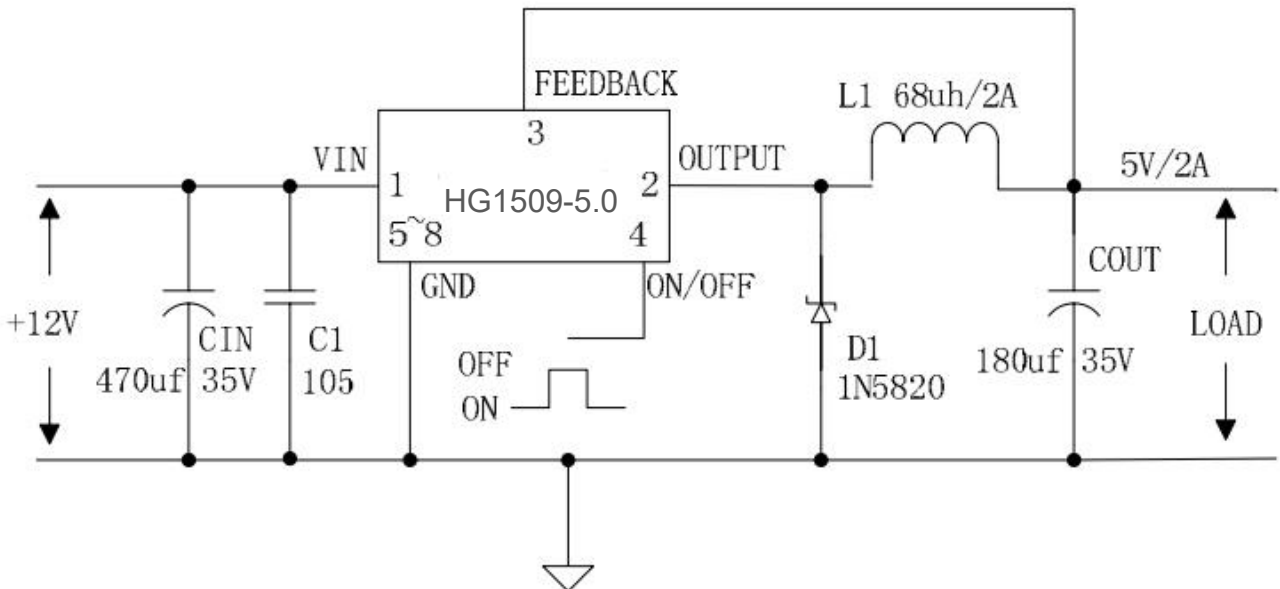

Figure 3. HG1509 Typical Application Circuit 12V-5V/2A

Absolute Maximum Ratings (Note1)

Parameter	Symbol	Value	Unit
Input Voltage	Vin	-0.3 to 42	V
Feedback Pin Voltage	VFB	-0.3 to Vin	V
ON/OFF Pin Voltage	VON/OFF	-0.3 to Vin	V
Output Switch Pin Voltage	VOutput	-0.3 to Vin	V
Power Dissipation	PD	Internally limited	mW
Thermal Resistance (SOP8) (Junction to Ambient, No Heatsink, Free Air)	RJA	100	°C/W
Operating Junction Temperature	TJ	-40 to 125	°C
Storage Temperature	TSTG	-65 to 150	°C
Lead Temperature (Soldering, 10 sec)	TLEAD	260	°C
ESD (HBM)		2000	V

Note1: Stresses greater than those listed under Maximum Ratings may cause permanent damage to the device. This is a stress rating only and functional operation of the device at these or any other conditions above those indicated in the operation is not implied. Exposure to absolute maximum rating conditions for extended periods may affect reliability.

Note1: Operating temperature range: -40°C to +125°C. This product is designed for industrial grade applications. For automotive grade versions compliant with AEC-Q100, please conduct internal screening per the standard or contact our sales team for availability.

HG1509-3.3 Electrical Characteristics

Ta = 25°C; unless otherwise specified.

Symbol	Parameter	Test Condition	Min.	Typ.	Max.	Unit
System parameters test circuit figure 4						
VOUT	Output, Voltage	Vin = 4.75V to 42V, Iload=0.2A to 2A	3.168	3.3	3.432	V
Efficiency	η	Vin=12V, Vout=3.3V, Iout=2A	-	75	-	%

HG1509-5.0 Electrical Characteristics

Ta = 25°C; unless otherwise specified.

Symbol	Parameter	Test Condition	Min.	Typ.	Max.	Unit
System parameters test circuit figure 4						
VOUT	Output, Voltage	Vin = 7V to 42V, Iload=0.2A to 2A	4.8	5	5.2	V
Efficiency	η	Vin=12V, Vout=5V, Iout=2A	-	82	-	%

HG1509-12 Electrical Characteristics

Ta = 25°C; unless otherwise specified.

Symbol	Parameter	Test Condition	Min.	Typ.	Max.	Unit
System parameters test circuit figure 4						
VOUT	Output, Voltage	Vin = 15V to 42V, Iload=0.2A to 2A	11.52	12	12.48	V
Efficiency	η	Vin=25V, Vout=12V, Iout=2A	-	90	-	%

HG1509-ADJ Electrical Characteristics

Ta = 25°C; unless otherwise specified.

Symbol	Parameter	Test Condition	Min.	Typ.	Max.	Unit
System parameters test circuit figure 4						
VOUT	Output, Voltage	Vin = 4.5V to 42V, Iload=0.2A to 2A	1.193	1.23	1.267	V
Efficiency	η	Vin=12V, Vout=3V, Iout=2A	-	74	-	%

Electrical Characteristics (DC Parameters)

Vin = 12V for the 3.3V, 5V, and Adjustable versions and Vin=24V for the 12V version, GND=0V, Vin & GND parallel connect a 220uF/50V capacitor; Iout=500mA, Ta = 25°C; the others floating unless otherwise specified.

Parameters	Symbol	Test Condition	Min.	Typ.	Max.	Unit
Input operation voltage	Vin		4.5		42	V
Shutdown Supply Current	ISTBY	VON/OFF=5V		80	200	uA
Quiescent Supply Current	Iq	VON/OFF =0V, VFB =Vin		2	10	mA
Oscillator Frequency	Fosc		127	150	173	Khz
Switch Current Limit	IL	VFB =0		4		A
ON/OFF Pin Threshold	VON/OFF	High (Regulator OFF) Low (Regulator ON)		1.4 0.8		V
ON/OFF Pin Input Leakage Current	IH	VON/OFF =2.5V (OFF)		5	30	uA
	IL	VON/OFF =0.5V (ON)		0.2	10	uA
Output Saturation Voltage	VCE	VFB=0V Iout=2A		1.2	1.4	V
Max. Duty Cycle	DMAX	VFB=0V		100		%

Test Circuit and Layout guidelines

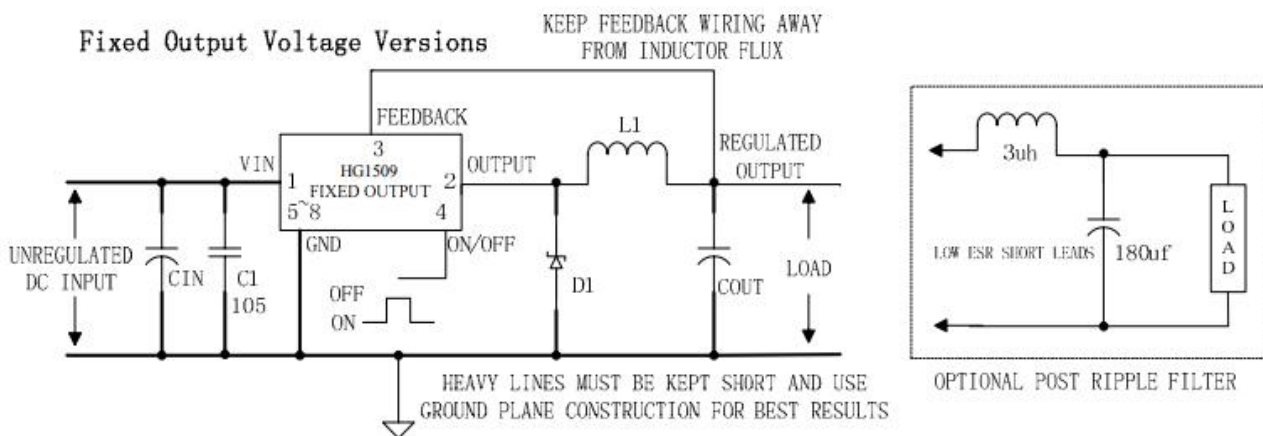

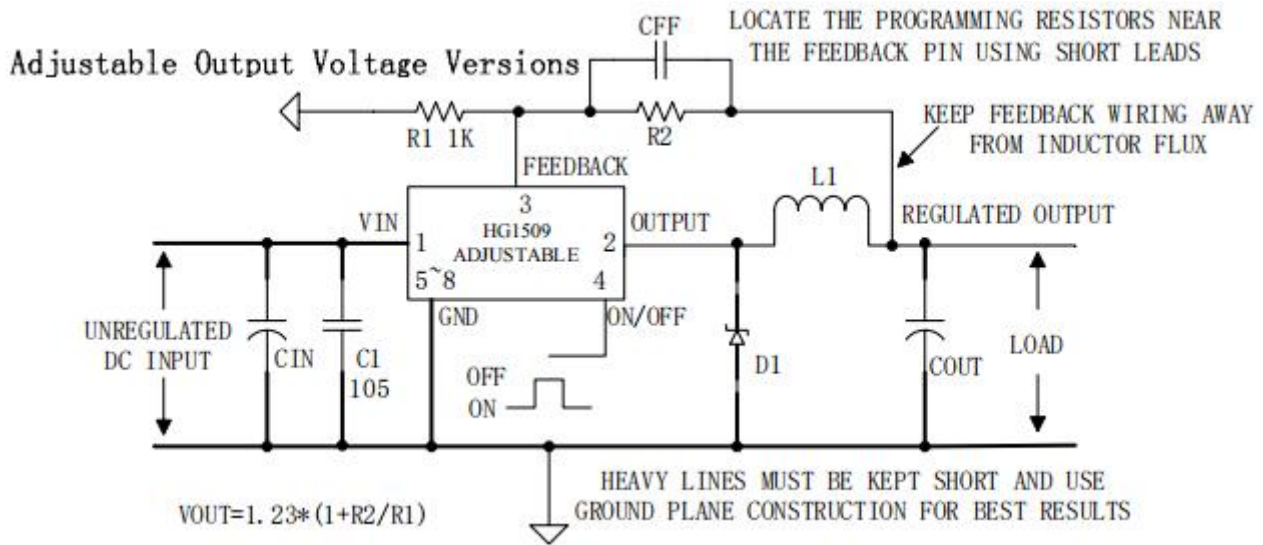

Figure 4. Standard Test Circuits and Layout Guides

Select R1 to be approximately 1K, use a 1% resistor for best stability.

C1 and CFF are optional; in order to increase stability and reduce the input power line noise, C1N and C1 must be placed near to PIN1 and PIN5~8;

For output voltages greater than approximately 10V, an additional capacitor CFF is required. The compensation capacitor is typically between 100 pf and 33 nf, and is wired in parallel with the output voltage setting resistor, R2. It provides additional stability for high output voltage, low input-output voltages, and/or very low ESR output capacitors, such as solid tantalum capacitors. $CFF = 1 / (31 * 1000 * R2)$; This capacitor type can be ceramic, plastic, silver mica, etc. (Because of the unstable characteristics of ceramic capacitors made with Z5U material, they are not recommended.)

HG1509 Series Buck Regulator Design Procedure (Fixed Output)

Conditions			Inductor (L1)	Output Capacitor (COUT)			
				Through Hole Electrolytic		Surface Mount Tantalum	
Output Voltage (V)	Load Current (A)	Max Input Voltage (V)	Inductance (uh)	Panasonic HFQ Series (uf/V)	Nichicon PL Series (uf/V)	AVX TPS Series (uf/V)	Sprague 595D Series (uf/V)
3.3	2	6	22	470/25	470/35	330/6.3	390/6.3
		10	33	330/35	330/35	330/6.3	390/6.3
		42	47	330/35	270/50	220/10	330/10
5	2	9	22	470/25	560/16	220/10	330/10
		20	68	180/35	180/35	100/10	270/10
		42	68	180/35	180/35	100/10	270/10
12	2	15	33	330/25	330/25	100/16	180/16
		20	68	180/25	180/25	100/16	120/20
		42	150	82/25	82/25	68/20	68/25

HG1509 Series Buck Regulator Design Procedure (Adjustable Output)

Output Voltage (V)	Through Hole Output Electrolytic			Surface Mount Output Capacitor		
	Panasonic HFQ Series (uf/V)	Nichicon PL Series (uf/V)	Feedforward Capacitor	AVX TPS Series (uf/V)	Sprague 595D Series (uf/V)	Feedforward Capacitor
2	820/35	820/35	33nf	330/6.3	470/4	33nf
4	560/35	470/35	10nf	330/6.3	390/6.3	10nf
6	470/25	470/35	3.3nf	220/10	330/10	3.3nf
9	330/25	330/25	1.5nf	100/16	180/16	1.5nf
12	330/25	330/25	1nf	100/16	180/16	1nf
15	220/25	220/35	680pf	68/20	120/20	680pf
24	220/35	150/35	560pf	33/25	33/25	220pf
28	100/50	100/50	390pf	10/35	15/50	220pf

Schottky Diode Selection Table

Current	Surface Mount	Through Hole	VR (The same as system maximum input voltage)				
			20V	30V	40V	50V	60V
1A		√	1N5817	1N5818	1N5819		
		√	1N5820	1N5821	1N5822		
3A		√	MBR320	MBR330	MBR340	MBR350	MBR360
	√		SK32	SK33	SK34	SK35	SK36
	√			30WQ03	30WQ04	30WQ05	
		√		31DQ03	31DQ04	31DQ05	
		√	SR302	SR303	SR304	SR305	SR306

Typical System Application for 3.3V Version

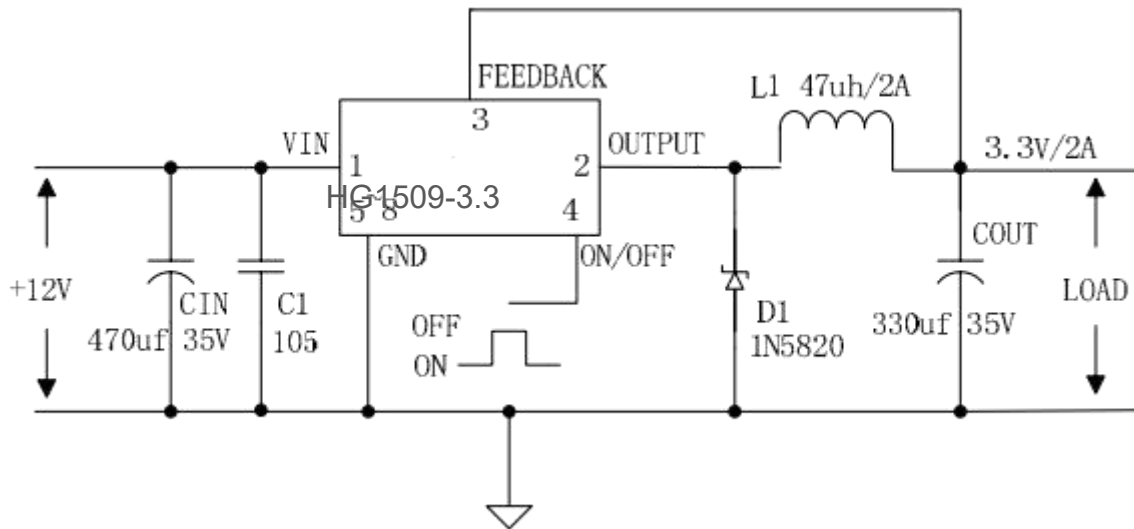

Figure 5. HG1509-3.3 System Parameters Test Circuit

Typical System Application for 5V Version

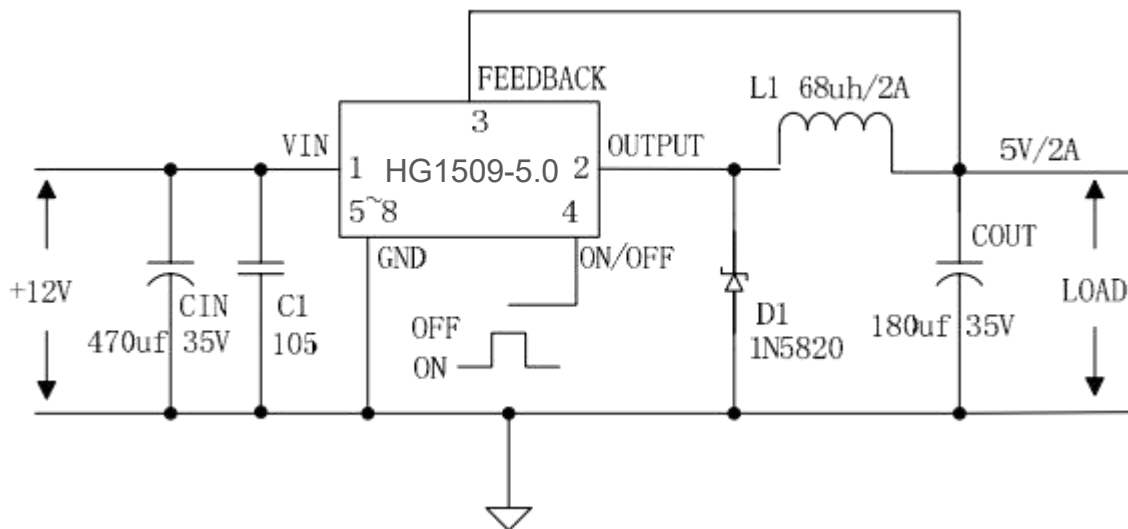

Figure 6. HG1509-5.0 System Parameters Test Circuit

Typical System Application for 12V Version

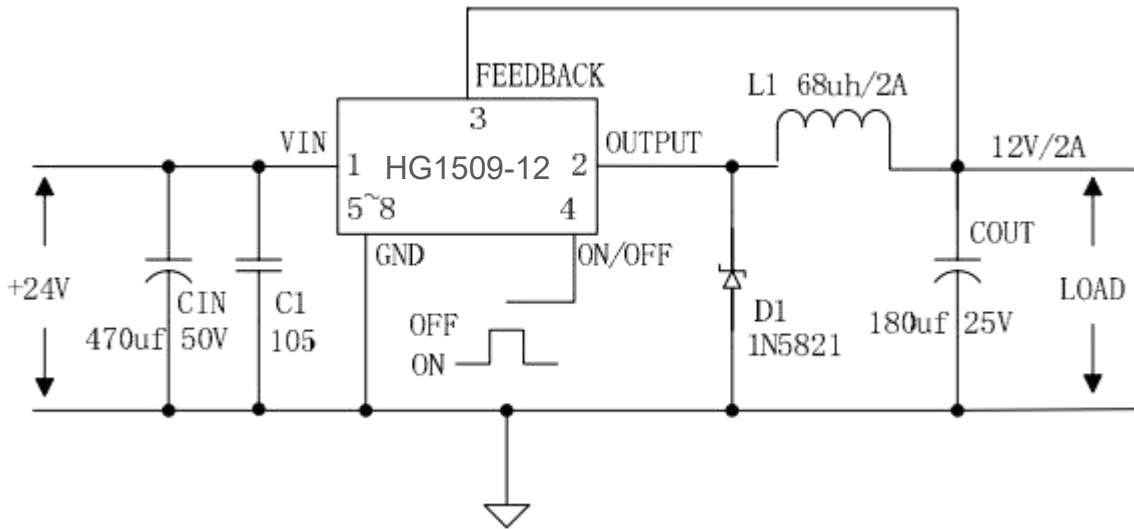

Figure 7. HG1509-12 System Parameters Test Circuit

Typical System Application for ADJ Version

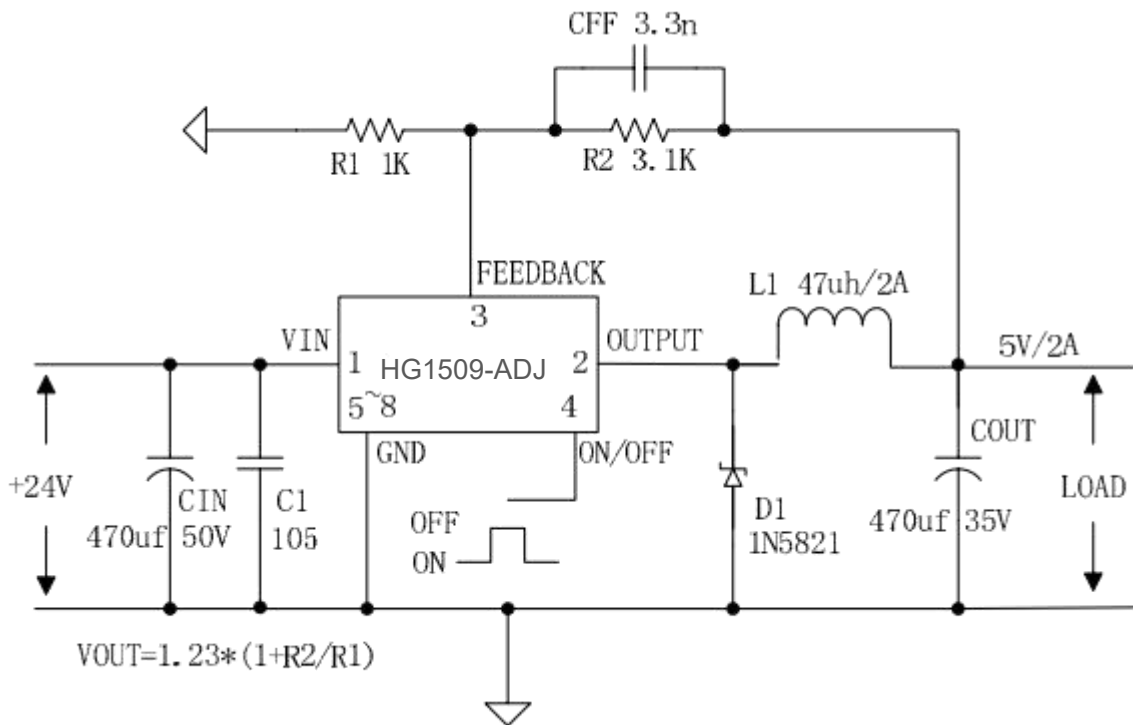
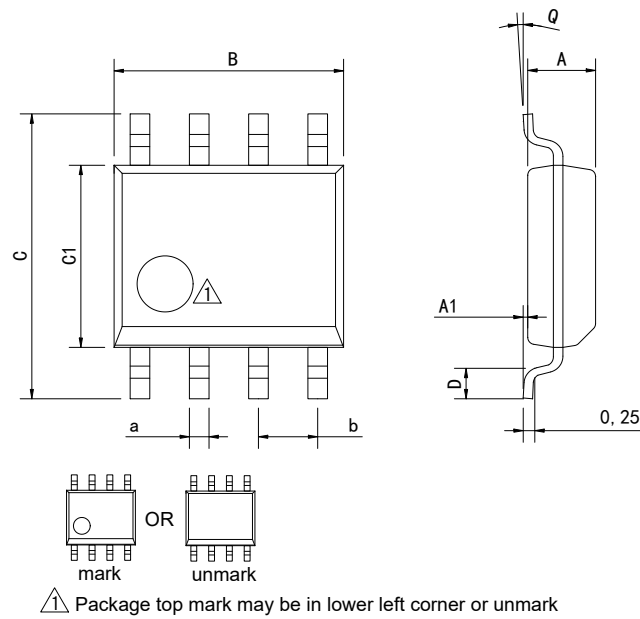

Figure 8. HG1509-ADJ System Parameters Test Circuit

Physical Dimensions

SOP-8



Dimensions In Millimeters(SOP-8)										
Symbol:	A	A1	B	C	C1	D	Q	a	b	
Min:	1.35	0.05	4.90	5.80	3.80	0.40	0°	0.35	1.27 BSC	
Max:	1.55	0.20	5.10	6.20	4.00	0.80	8°	0.45		

ESOP-8

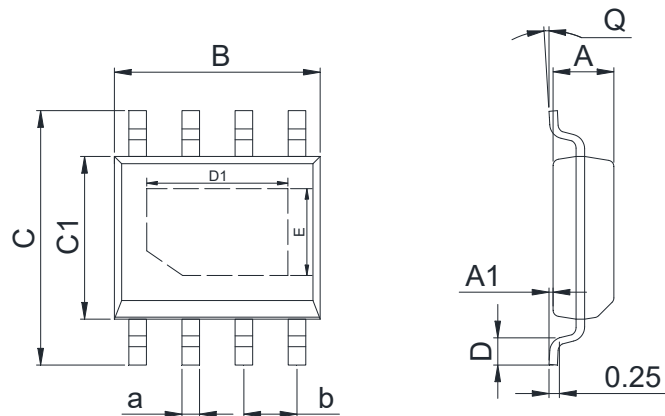

Dimensions In Millimeters(ESOP-8)											
Symbol:	A	A1	B	C	C1	D	D1	E	Q	a	b
Min:	1.35	0.05	4.90	5.80	3.80	0.40	3.20	2.31	0°	0.35	1.27 BSC
Max:	1.55	0.20	5.10	6.20	4.00	0.80	3.40	2.51	8°	0.45	

Revision History

REVISION NUMBER	DATE	REVISION	PAGE
V1.0	2020-9	New	1-13
V1.1	2022-10	Update encapsulation type、 Update MARKING	1
V1.2	2024-11	Update Lead Temperature	5
V1.3	2025-11	Update important statements、 Update SOP-8 Dimension drawing	11、 13

IMPORTANT STATEMENT:

Huaguan Semiconductor reserves the right to change products and services offered without prior notice. Customers should obtain the latest relevant information before placing orders and verify that such information is current and complete. Huaguan Semiconductor assumes no responsibility or liability for altered documents.

Customers are responsible for complying with safety standards and implementing safety measures when using Huaguan Semiconductor products in system design and end-product manufacturing. You assume full responsibility for: selecting the appropriate Huaguan Semiconductor products for your application; designing, validating, and testing your application; and ensuring that your application complies with applicable standards and all other safety, security, or other requirements. This is to prevent potential risks that may lead to personal injury or property damage.

Huaguan Semiconductor products are not approved for use in life support, military, aerospace, or other high-risk applications. Huaguan products are neither intended nor warranted for use in such systems or equipment. Any failure or malfunction may lead to personal injury or severe property damage. Such applications are deemed "Unsafe Use." Unsafe Use includes, but is not limited to: surgical and medical equipment, nuclear energy control equipment, aircraft or spacecraft instruments, control or operation of vehicle power, braking, or safety systems, traffic signal instruments, all types of safety devices, and any other applications intended to support or sustain life. Huaguan Semiconductor shall not be liable for consequences resulting from Unsafe Use in these fields. Users must independently evaluate and assume all risks. Any issues, liabilities, or losses arising from the use of products beyond their approved applications shall be solely borne by the user. Users may not claim any compensation from Huaguan Semiconductor based on these terms. If any third party claims against Huaguan Semiconductor due to such Unsafe Use, the user shall compensate Huaguan Semiconductor for all resulting damages and liabilities.

Huaguan Semiconductor provides technical and reliability data (including datasheets), design resources (including reference designs), application or other design advice, web tools, safety information, and other resources for its semiconductor products. However, no guarantee is made that these resources are free from defects, and no express or implied warranties are provided. The use of testing and other quality control techniques is limited to Huaguan Semiconductor's quality assurance scope. Not all parameters of each device are tested.

Huaguan Semiconductor's documentation authorizes you to use these resources only for developing applications related to the products described herein. You are not granted rights to any other intellectual property of Huaguan Semiconductor or any third party. Any other reproduction or display of these resources is strictly prohibited. You shall fully indemnify Huaguan Semiconductor and its agents against any claims, damages, costs, losses, and liabilities arising from your use of these resources. Huaguan Semiconductor shall not be held responsible.