



钰地半导体
Tudi Semiconductor

Product Specification

TUDI-ADM3202

3.0V to 5.5V, Low-Power, up to 120Kbps, True RS-232
Transceivers Using Four 0.1 μ F External Capacitors

网址 www.sztdbdt.com 🔍

用芯智造 · 卓越品质

**semiconductor device
manufacturer**

- Design
- research and development
- production
- and sales



Features

- 300 μ A Supply Current
- 250Kbps Maximum Guaranteed Data Rate
- 3V/ μ s Minimum Rise Rate
- Enhanced-level ESD Specifications:
 \pm 15kV IEC61000-4-2 Air Discharge
 \pm kV IEC61000-4-2 Contact Discharge
- Available in DIP-16, SO-16, TSSOP16, SOP16L (W) Packages

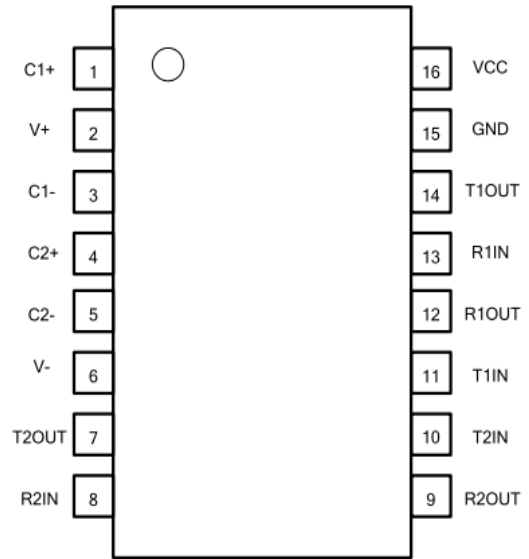

Figure 1. Pin Diagram

Description

The ADM3202 transceivers feature a proprietary low-voltage difference transmitter output stage that provides true RS-232 performance via a dual pump, with supply voltages from 3.0V to 5.5V. These devices require only four small, 0.1 μ F external charge pump capacitors. The ADM3202 guarantees reliable operation up to data rates of 120kbps while maintaining RS-232 output levels.

The ADM3202 contains 2 receivers and 2 drivers.

Applications

- Notebook, Subnotebook, and Palmtop Computers
- High-Speed Modems
- Battery-Powered Equipment
- Hand-Held Equipment
- Peripherals
- Printers



Pin description

PIN	SYMBOL	DESCRIPTION
1	C1+	Positive Terminal for the first Charge Pump Capacitor
2	V+	Doubled Voltage Terminal
3	C1-	Negative Terminal for the first Charge Pump Capacitor
4	C2+	Positive Terminal for the second Charge Pump Capacitor
5	C2-	Negative Terminal for the second Charge Pump Capacitor
6	V-	Inverted Voltage Terminal
7	T2OUT	Second Transmitter Output Voltage
8	R2IN	Second Receiver Input Voltage
9	R2OUT	Second Receiver Output Voltage
10	T2IN	Second Transmitter Input Voltage
11	T1IN	First Transmitter Input Voltage
12	R1OUT	First Receiver Output Voltage
13	R1IN	First Receiver Input Voltage
14	T1OUT	First Transmitter Output Voltage
15	GND	Ground
16	VCC	Supply Voltage



Parameter limit

PARAMETER	SYMBOL	VALUE	UNIT
Supply voltage	VCC	-0.3~+6	V
Doubled Voltage Terminal	V+	VCC-0.3~+7	V
Inverted Voltage Terminal	V-	+0.3~-7	V
$V+ + V- $		+13	V
Transmitter Input Voltage Range	T1IN,T2IN	-0.3~+6	V
Receiver Input Voltage Range	R1IN,R2IN	±25	V
Transmitter Output Voltage Range	T1OUT,T2OUT	±13.2	V
Receiver Output Voltage Range	R1OUT,R2OUT	-0.3~VCC+0.3	V
Operating Temperature		-40~85	°C
Storage Temperature		-60~150	°C
Soldering Temperature		300	°C
Continuous Power	SOP16	760	mW
	DIP16	840	mW

The maximum limit parameters means that exceeding these values may cause irreversible damage to the device. Under these conditions, it is not conducive to the normal operation of the device. The continuous operation of the device at the maximum allowable rating may affect the reliability of the device. The reference point for all voltages is ground.

Logic Input Electrical Characteristics

PARAMETER	SYMBOL	CONDITION	MIN.	TYP.	MAX.	UNIT
Logic Control Low Level	VTTIN_L	T1IN,T2IN			0.8	V
Logic Control High Level	VTTINH	T1IN,T2IN	2			V
Logic Control Hysteresis		T1IN,T2IN		0.3		V
Input Logic Current	ITIN	T1IN,T2IN			±1	μA

(If there is no additional explanation,typical value is tested when VCC=+3.3V,Temp=25 ,C1-C4=1 μ F)



Receiver Output Electrical Characteristics

PARAMETER	SYMBOL	CONDITION	MIN.	TYP.	MAX.	UNIT
Receiver Output Logic-Low Voltage	VROL	IOUT=1.6mA, VCC=5V or 3.3V			0.4	V
Receiver Output Logic-High Voltage	VROH	IOUT=-0.5mA, VCC=5V or 3.3V	VCC-0.6	VCC-0.1		V

(If there is no additional explanation,typical value is tested when VCC=+3.3V,Temp=25 ,C1-C4=1 μ F)

Receiver Input Electrical Characteristics

PARAMETER	SYMBOL	CONDITION	MIN.	TYP.	MAX.	UNIT
Receiver Input Range	VRIN		-25		+25	V
Receiver Input Low Threshold	VRL	VCC=3.3V	0.6	1.1		V
		VCC=5V	0.8	1.5		V
Receiver Input High Threshold	VRIH	VCC=3.3V		1.5	2.4	V
		VCC=5V		1.9	2.4	V
Receiver Input Hysteresis				0.4		V
Receiver Input Impedance	RRIN		3	5	7	kΩ

(If there is no additional explanation,typical value is tested when VCC=+3.3V,Temp=25 ,C1-C4=1 μ F)

Transmitter Output Electrical Characteristics

PARAMETER	SYMBOL	CONDITION	MIN.	TYP.	MAX.	UNIT
Transmitter Output Swing	VTOUT	All output ports of transmitter connect 3kΩload to ground	±4		±5	V
Transmitter Output Impedance	RTOUT	VCC=0V, Transmitter Input=±2V	300			Ω
Transmitter Short-Circuit Current	Itsc				60	mA

(If there is no additional explanation,typical value is tested when VCC=+3.3V,Temp=25 ,C1-C4=1 μ F)



Supply Current

PARAMETER	SYMBOL	CONDITION	MIN.	TYP.	MAX.	UNIT
Supply Current with no Load	I _{sup}			2		mA

(If there is no additional explanation,typical value is tested when VCC=+3.3V,Temp=25 ,C1-C4=1 μ F)

ESD Protection

PARAMETER	SYMBOL	CONDITION	MIN.	TYP.	MAX.	UNIT
R1IN、 R2IN T1OUT、 T2OUT		HBM		±15		KV
		Air Discharge		±15		KV
		Contact Discharge		±8		KV

Switching Characteristics Parameter

PARAMETER	SYMBOL	CONDITION	MIN.	TYP.	MAX.	UNIT
Rate	Speed	RL=3kΩ, CL=1000pF		120		kbps
Receiver Propagation delay	tRPHL	CL=150pF		300		ns
	tRPLH			300		ns
tRPHL-tRPLH				150		ns
tTPHL-tTPLH				150		ns
Transmitter Slew Rate	SR	RL=3kΩ~7kΩ, CL=150pF~1000pF from-3.0V~3.0V or from3.0V~-3.0V See figures 2 and 3	4		30	V/μs

(If there is no additional explanation,typical value is tested when VCC=+3.3V,Temp=25 ,C1-C4=1 μ F)



TEST CIRCUIT

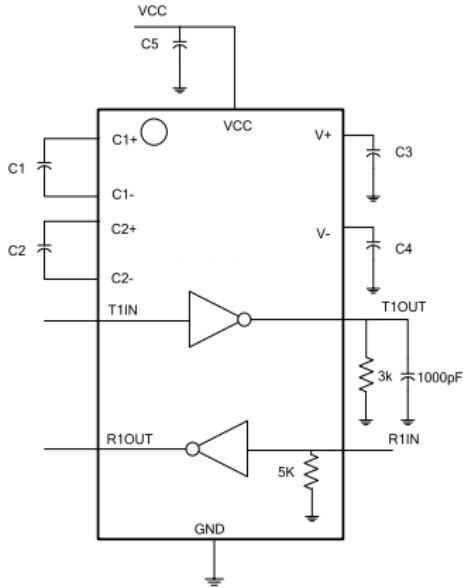

Figure 2 minimum swing rate test circuit

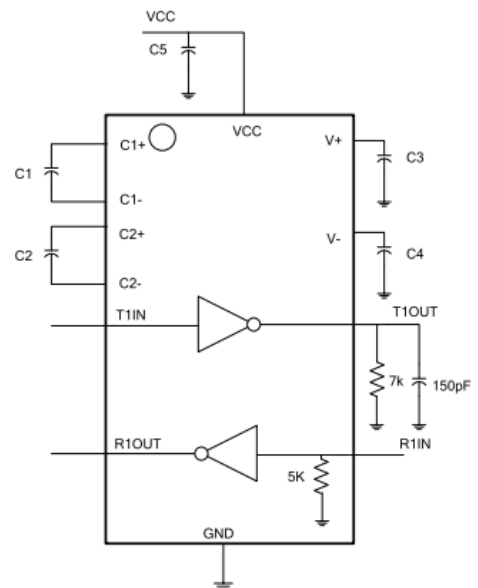

Figure 3 maximum swing rate test circuit

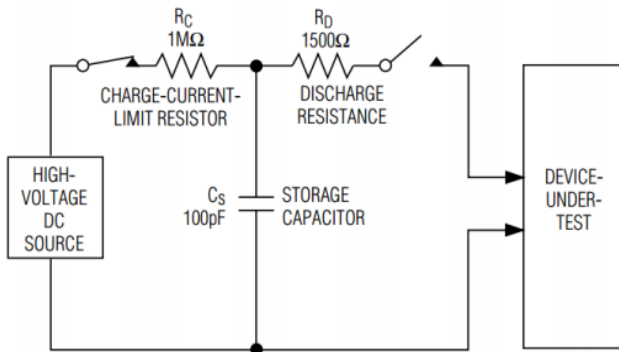

Figure 4 ESD test model of human body mode

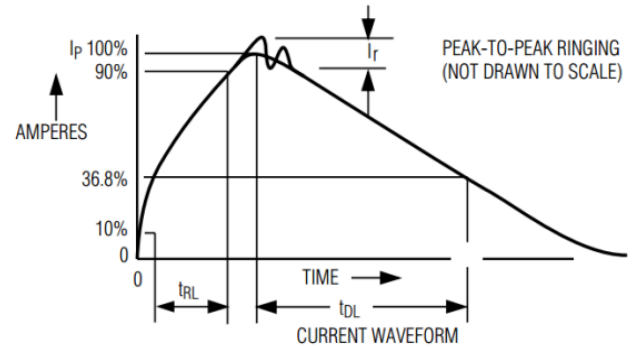

Figure 5 human body mode current waveform

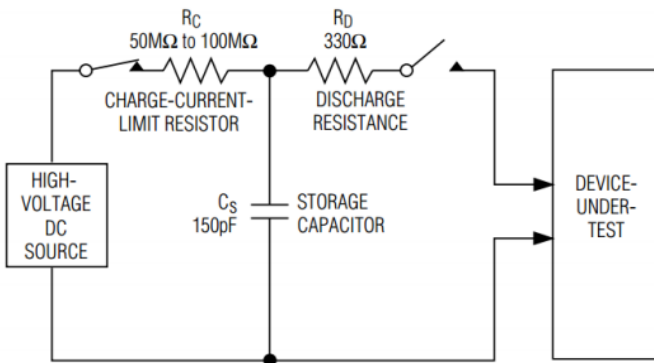

Figure 6 ESD test model of IEC 1000-4-2

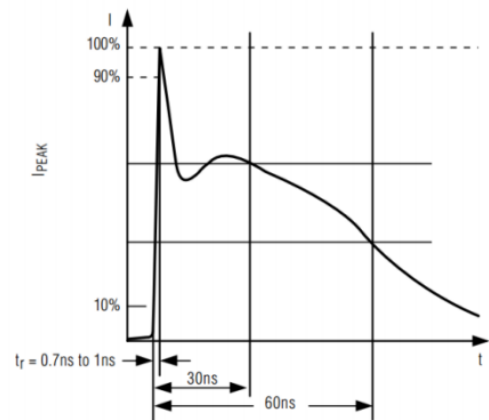

Figure 7 current waveform of IEC 1000-4-2 ESD



Description

RS232 Receiver
The 3202 has two separate receivers that convert the RS-232 signal to the CMOS logic output level.
ESD Protection
All pins of 3202 adopt ESD protection structure, and all driver outputs and receiver inputs have additional electrostatic protection capability. It can withstand $\pm 15\text{kV}$ ESD (HBM) discharge, contact discharge above $\pm 8\text{kV}$ and air gap discharge above $\pm 15\text{kV}$. The ESD protection structure can withstand the impact of high voltage ESD under all conditions, including standard working mode and power-off mode.
Typical Application
Typical dual-Path application scenarios are shown in Figure 8, where the C1-C5 typical capacitance value is $0.1\mu\text{F}$.
Dual Charge-Pump Operation
3202 has a two-way charge pump inside to support the chip's voltage conversion work. Dual-electric pump provides $+5.5\text{V}$ and -5.5V output voltage in the range of $3.0\text{--}5.5\text{V}$. Each charge pump requires a capacitor (C1, C2) and an energy storage capacitor (C3, C4) to generate $V+$ and $V-$ power supplies, as shown in Fig 8.
RS232 Transmitter
Convert the TTL/CMOS logic voltage to a voltage compatible with the EIA/TIA-232 standard. 3202 Transmitter can guarantee 250kbps data rate under the worst operating conditions (Parallel load of $3\text{k}\Omega$ resistor and 1000pF capacitor). Transmitter can drive multiple receivers in parallel. There is no pull-up resistance inside the input terminals T1IN and T2IN of 3202 transmitter. If the transmitter is not used, the unused input terminals T1IN and T2IN can be connected to GND or VCC.

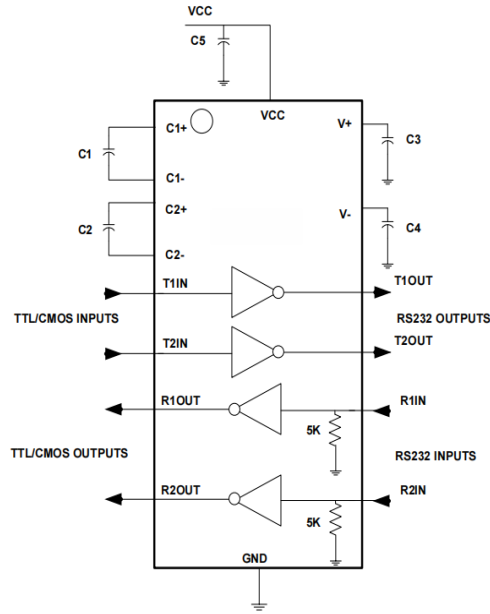

Figure 8 Typical dual-Path application scenarios

Order information

Order Number	Package	Package Quantity	Marking On The park	Temperature
ADM3202ANZ-TUDI	DIP16	Tube,25,A box of 1000	ADM3202ANZ	-40°C to 85°C
ADM3202ARNZ-REEL-TUDI	SOP16	Tape,Reel,2500	ADM3202ARNZ	
ADM3202ARUZ-REEL-TUDI	TSSOP16	Tape,Reel,2500	ADM3202A	
ADM3202ARWZ-REEL-TUDI	SMD16	Tape,Reel,1000	ADM3202ARWZ	



Package SSOP16

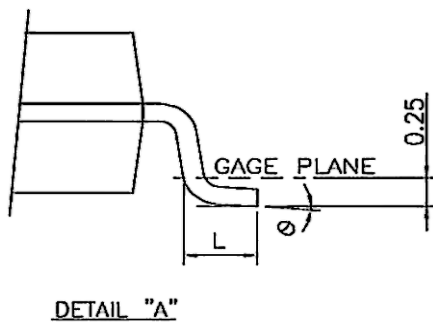
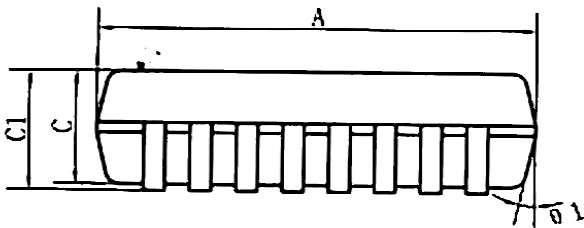
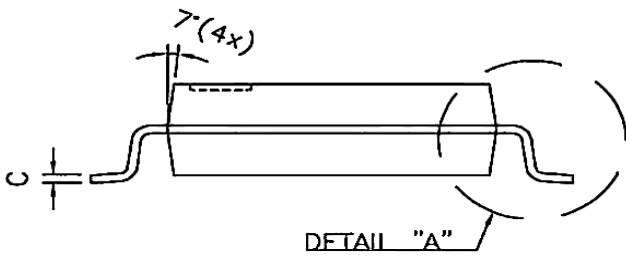
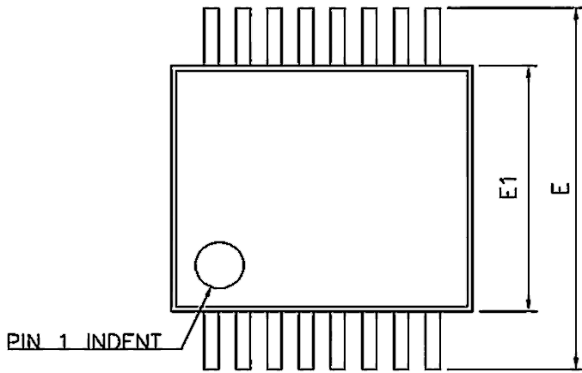

SIZE SYMBOL	MIN/mm	MAX/mm
A	6.15	6.25
A1	0.30TYP	
A2	0.65TYP	
A3	0.675TYP	
B	5.25	5.35
B1	7.65	7.95
B2	0.60	0.80
C	1.70	1.80
C1	1.75	1.95
C2	0.799	
C3	0.152	
C4	0.172	
H	0.05	0.15
θ	12°TYP4	
O1	12°TYP4	
O2	10°TYP	
O3	0°~8°	
R	0.20°TYP	
R	0.15°TYP	



Package TSSOP16

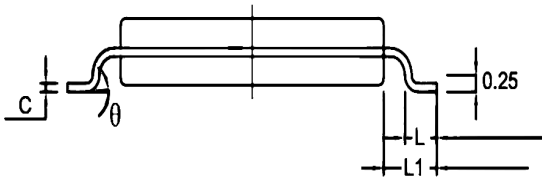
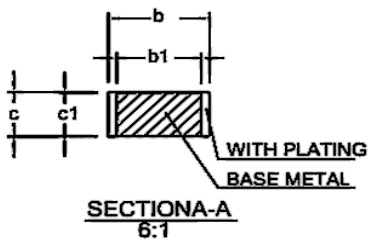
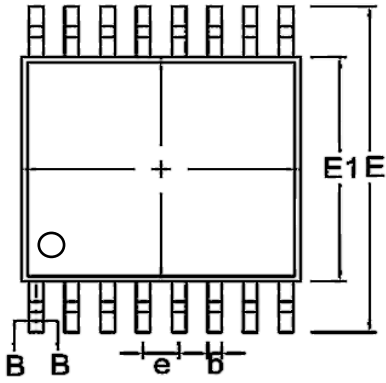

SIZE SYMBOL	MIN./mm	TYP./mm	MAX./mm
A	--	--	1.20
A1	0.05		0.15
A2	0.90	1.00	1.05
b	0.20	--	0.30
b1	0.19	0.22	0.25
C	0.110	0.127	0.145
cl	0.12	0.13	0.14
D	4.86	4.96	5.06
E	6.20	6.40	6.60
E1	4.30	4.40	4.50
e	0.65BSC		
L	0.45	0.60	0.75
L1	1.00BSC		
	0°	--	8°

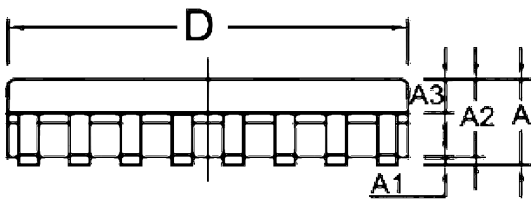



Package SOP16

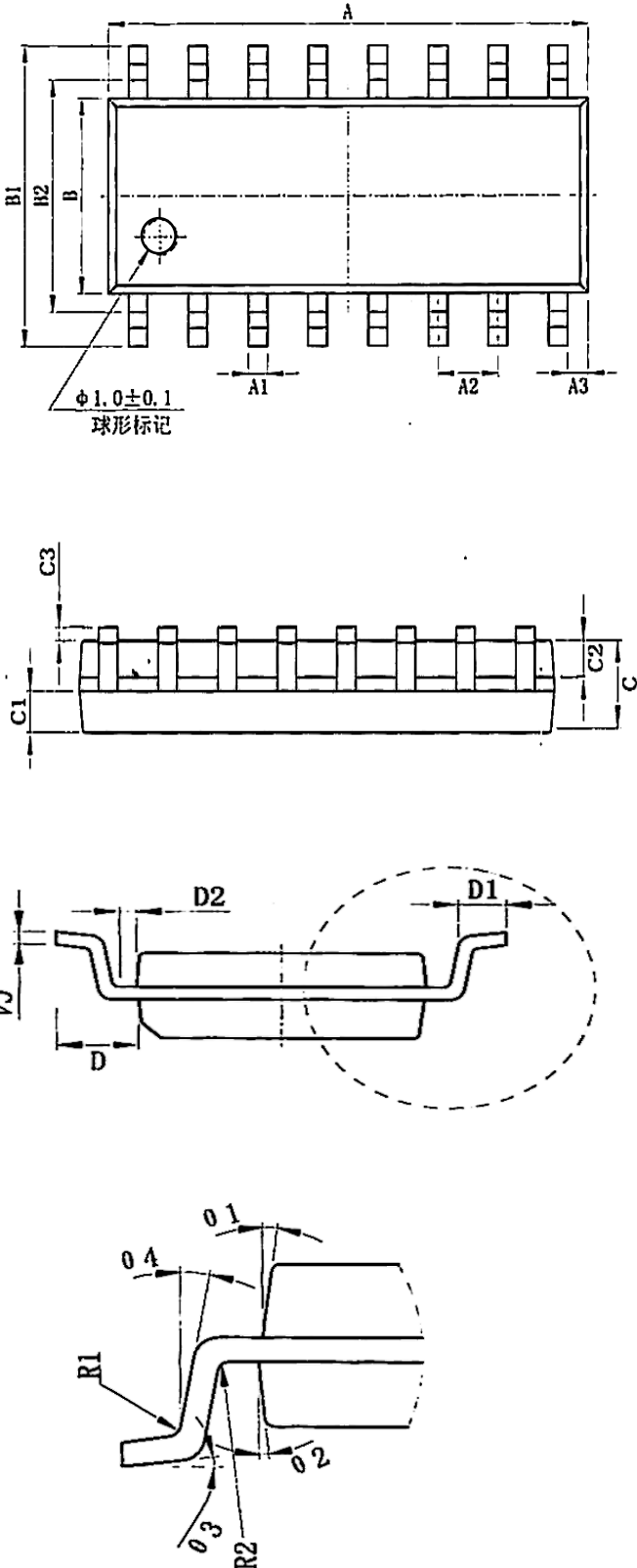

SIZE	MIN./mm	MAX./mm
SYMBOL		
A	9.80	10.00
A1	0.356	0.456
A2	1.27TYP	
A3	0.302TYP	
B	3.85	3.95
B1	5.84	6.24
B2	5.00 TYP	
C	1.40	1.60
C1	0.61	0.71
C2	0.54	0.64
C3	0.05	0.25
C4	0.203	0.233
D	1.05 TYP	
D1	0.40	0.70
D2	0.15	0.25
R1	0.20TYP	
R2	0.20TYP	
O1	8°~12°TYP4	
O2	8°~12°TYP4	
O3	0°~8°	
O4	4°~12°	



Package SMD16

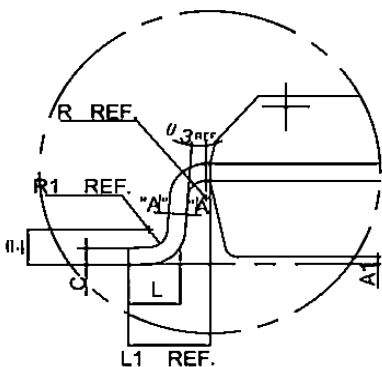
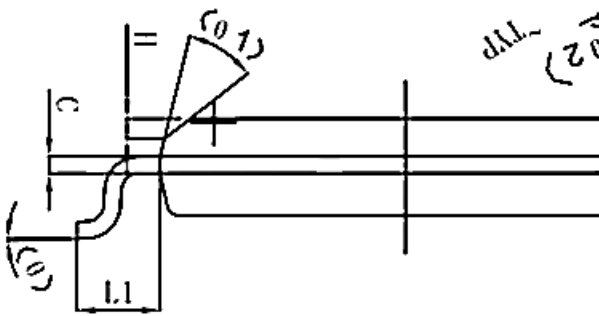
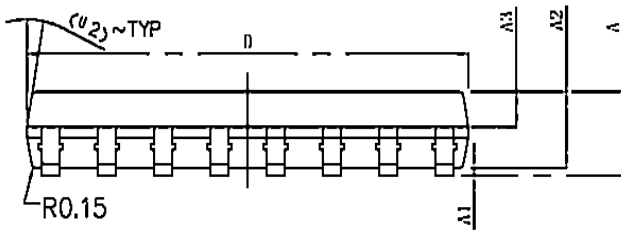
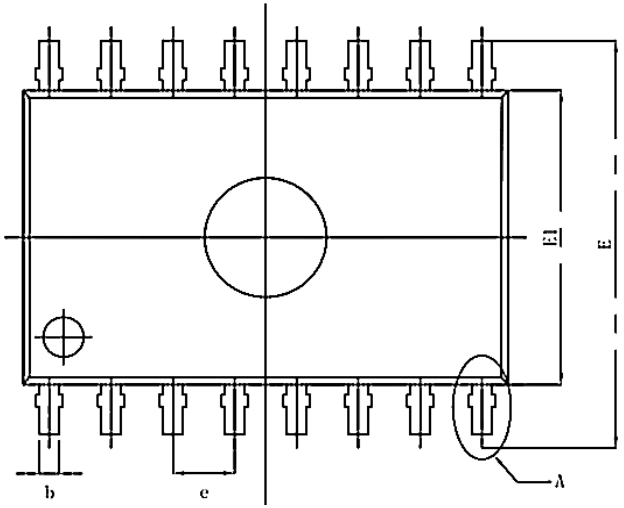

SIZE SYMBOL	MIN./mm	MAX./mm
A	-	2.65
A1	0.10	0.30
A2	2.25	2.35
A3	0.97	1.07
D	10.10	10.50
E	10.26	10.60
E1	7.30	7.70
e	1.27BSC	
L	0.55	0.85
L1	1.4BSC	
H	0.345	0.365
R	0.20TYP	
R1	0.30TYP	
θ	0°	8°
θ 1	45° TYP	
02	12° TYP	
03	0°	8°
04	0°	10°



Package DIP16

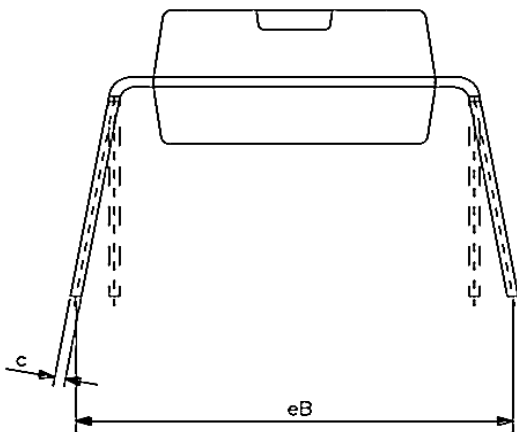
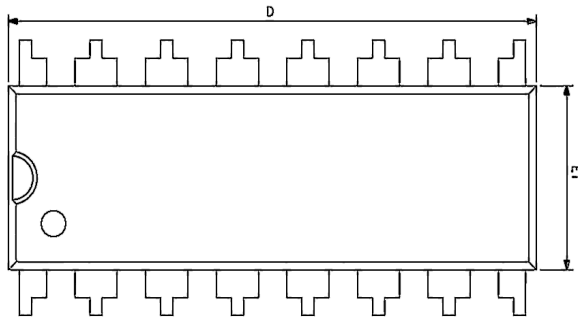
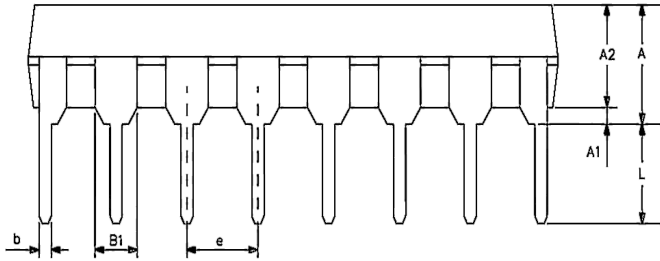

SIZE SYMBOL	MIN./mm	MAX./mm
A2	3.20	3.60
A1	0.51	—
A	3.60	5.33
L	3.00	3.60
b	0.36	0.56
B1	1.52	
D	18.80	19.94
E1	6.20	6.60
e	2.54	
C	0.20	0.36
eB	7.62	9.30
R	0.20TYP	
R1	0.30TYP	
θ	0°	8°
θ_1	45°TYP	
θ_2	12°TYP	
θ_3	0°	8°
θ_4	0°	10°



Important statement:

- TUDI Semiconductor reserves the right to modify the product manual without prior notice! Before placing an order, customers need to confirm whether the obtained information is the latest version and verify the completeness of the relevant information.
- Any semi-guide product is subject to failure or malfunction under specified conditions. It is the buyer's responsibility to comply with safety standards when using TUDI Semiconductor products for system design and whole machine manufacturing. And take the appropriate safety measures to avoid the potential in the risk of loss of personal injury or loss of property situation!
- TUDI Semiconductor products have not been licensed for life support, military, and aerospace applications, and therefore TUDI Semiconductor is not responsible for any consequences arising from the use of this product in these areas.
- If any or all TUDI Semiconductor products (including technical data, services) described or contained in this document are subject to any applicable local export control laws and regulations, they may not be exported without an export license from the relevant authorities in accordance with such laws.
- The specifications of any and all TUDI Semiconductor products described or contained in this document specify the performance, characteristics, and functionality of said products in their standalone state, but do not guarantee the performance, characteristics, and functionality of said products installed in Customer's products or equipment. In order to verify symptoms and conditions that cannot be evaluated in a standalone device, the Customer should ultimately evaluate and test the device installed in the Customer's product device.
- TUDI Semiconductor documentation is only allowed to be copied without any alteration of the content and with the relevant authorization. TUDI Semiconductor assumes no responsibility or liability for altered documents.
- TUDI Semiconductor is committed to becoming the preferred semiconductor brand for customers, and TUDI Semiconductor will strive to provide customers with better performance and better quality products.