



钲地半导体  
Tudi Semiconductor

## Product Specification

TUDI-UCC27323/27324/27325

Dual High-Speed 4A MOSFET Drivers

网址 [www.sztdbdt.com](http://www.sztdbdt.com) Q

用芯智造 · 卓越品质

semiconductor device  
manufacturer

- Design
- research and development
- production
- and sales



## Features

- High Peak Output Current: 4A
- Wide Supply Voltage Operating Range:4.5V to 25V
- High Capacitive Load Drive Capability1000pF in 11ns(typical)
- Short Delay Times:35ns (typical)
- Matched Rise/Fall Times
- Low Output Impedance
- Low Supply Current
- Over-temperature Protection
- Under-voltage Lockout
- Non-overlapped Drive Tech
- ESD Protected:2.0kV
- Input withstands negative inputs up to 5V
- Available in Green SOP8 and DIP8

## Applications

- Wireless Power Transmitter
- Switch Mode Power Supplies
- Power MOSFET Drivers
- Pulse Transformer Drivers
- Line Drivers
- CCD Driver
- Class D Switching Amplifiers

## Description

The UCC27323/27324/27325 are matched dual power MOSFET drivers. Unique circuit design enables high speed operation capable of delivering peak currents of 4A into 1000pF capacitive loads.

Improved speed and drive capability are enhanced by matched rise and fall delay times. These matched delays maintain the integrity of input-to-output pulse-widths to reduce timing errors and clockskew problems. Dynamic switching losses are minimized with non-overlapped drive techniques. These devices are highly latch-up resistant within their power and voltage ratings. They are not subject to damage when up to 5V of noise spiking (of either polarity)occurs on the ground pin.All terminals are fully protected against Electrostatic Discharge (ESD)up to 2.0 kV.

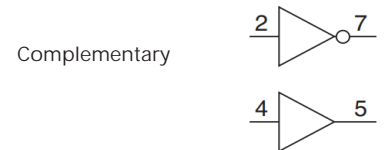
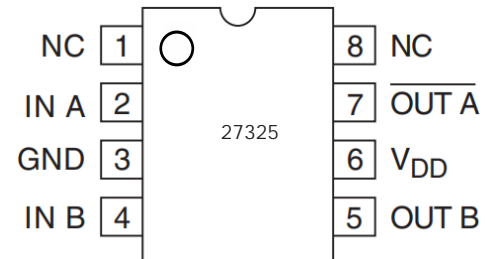
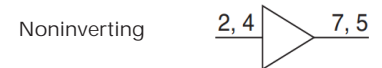
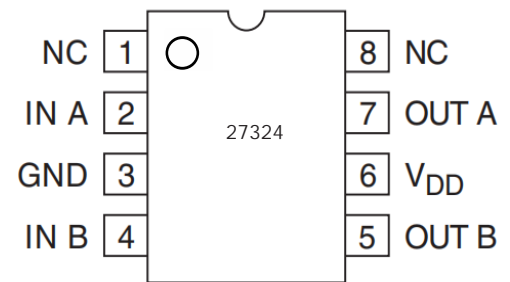
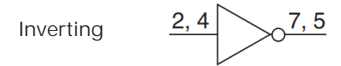
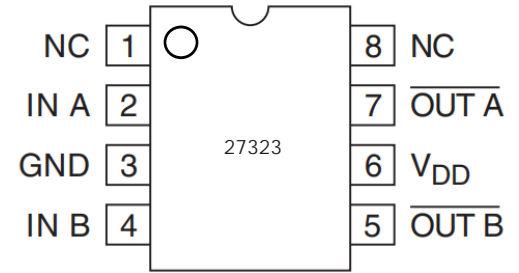



## Pin Description

Pin	Name	Description
1	NC	No connection
2	IN A	Input A
3	GND	Ground
4	In B	Input B
5	OUT B	Output of Channel B
6	VDD	Power Supply
7	OUTA	Output of Channel A
8	NC	No connection
-	PAD	Exposed Metal Pad

## Function Table

		UCC27323		UCC27324		UCC27325	
INA	INB	OUTA	OUT B	OUTA	OUTB	OUTA	OUTB
L	L	H	H	L	L	H	L
L	H	H	L	L	H	H	H
H	L	L	H	H	L	L	L
H	H	L	L	H	H	L	H

## Thermal Data

Parameter	Rating	Unit
Package Thermal Resistance	155(SOP8) 90(DIP8)	°CW



## Functional Block Diagram

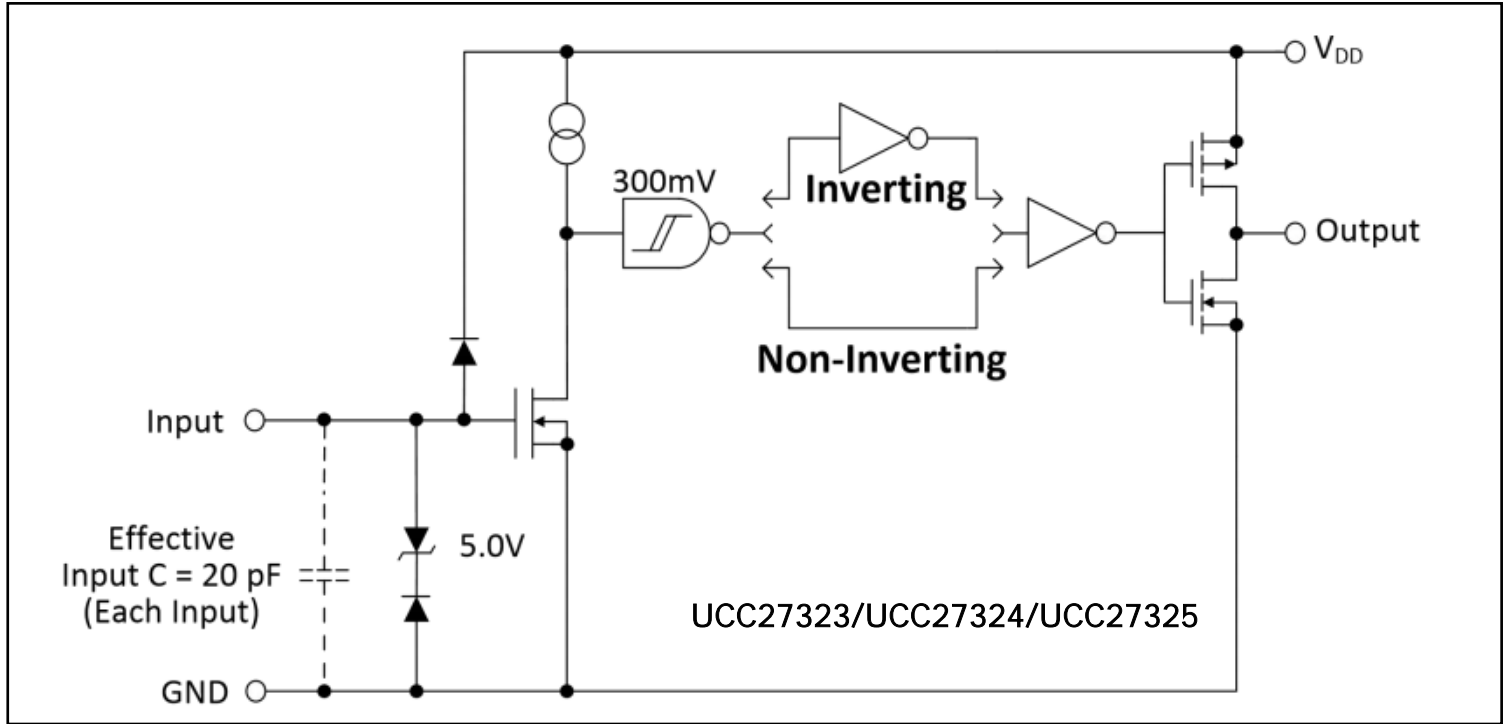

### Note

- 1: UCC27323 has two inverting drivers, while the UCC27324 has two non-inverting drivers. The UCC27325 has one inverting and one non-inverting driver.
- 2: Ground any unused driver input.

## Absolute Maximum Ratings

Parameter	Min	Max	Unit
DC supply voltage $V_s$		26	V
Operating junction temperature	-40	125	
Storage temperature	-55	150	
Maximum input voltage	GND-5	VDD+0.3	V
Combined peak output current		4	A

Note: Stresses exceeding the absolute maximum ratings may damage the device. The device may not function or be operable above the recommended operating conditions and stressing the parts to these levels is not recommended. In addition, extended exposure to stresses above the recommended operating conditions may affect device reliability. The absolute maximum ratings are stress ratings only.



## Recommended Operating Conditions

Parameter	Rating	Unit
DC Supply Voltage	4.5-25	V
Operating ambient temperature	-40~125	°C

## Additional description

Output A and B
MOSFET driver outputs A and B are low-impedance,CMOS push-pull style outputs.The pull-downand pullup devices are of equal strength,making the rise and fall times equivalent.
Inputs A and B
MOSFET driver inputs A and B are high-impedance,TTL/CMOS compatible inputs.These inputsalso have 300 mV of hysteresis between the high and low thresholds that prevents output glitchingeven when the rise and fall time of the input signal is very slow.
Supply Input (VDD)
The VDD input is the bias supply for the MOSFET driver and is rated for 4.5V to 25V with respect tothe Ground pin.The VDD input should be bypassed with local ceramic capacitors.The value ofthese capacitors should be chosen based on the capacitive load that is being driven.A value of 1.0μF is suggested.
Ground(GND)
Ground is the device return pin.The Ground pin(s)should have a low-impedance connection to thebias supply source return.High peak current flows out the Ground pin(s)when the capacitive load isbeing discharged.
Exposed Metal Pad
The exposed metal pad of the DFN-8 package is not internally connected to any potential. Therefore,this pad can be connected to a ground plane or other copper plane on a Printed Circuit Board(PCB),to aid in heat removal from the package.



## Electrical Characteristics

(Typical values are tested at  $T_A=25^\circ\text{C}$ ,  $V_{DD}=25\text{V}$ )

Parameter	Symbol	Conditions	Min.	Typ.	Max.	Unit
<b>Input</b>						
Input Signal High Threshold	$V_{IH}$		1.8			V
Input Signal Low Threshold	$V_{IL}$				0.7	V
Input Signal Hysteresis	$V_{HYS}$			0.3		V
Input Current	$I_{in}$	OV $V_{In}$ $V_{DD}$			$\pm 1$	$\mu\text{A}$
<b>Output</b>						
Pull-Up Resistance	$R_{oH}$	Source Current = 10mA		2.0		
Pull-Down Resistance	$R_{oL}$	Sink Current = -10mA		2.0		
Peak Output Current	$I_{pk}$	Source Current, $f=1\text{kHz}$ , $CL=1000\text{pF}$		4		A
		Sink Current, $f=1\text{kHz}$ , $CL=1000\text{pF}$		4		
Continuous Output Current	$I_{oc}$	Source /Sink Current		$\pm 200$		mA
<b>Power supply Current</b>						
Power Supply Current	$I_{cc}$	$V_{INA}=V_{INB}=3\text{V}$		0.9		mA
		$V_{INA}=V_{INB}=0\text{V}$		0.5		
Operating Voltage Range	$V_{DD}$		4.5		25	V
Under-Voltage Lockout ONThreshold				3.6	4	V
Under-Voltage LockoutHysteresis				0.5		V
<b>Switching characteristics</b>						
Rise Time	$t_R$	$CL=1000\text{pF}$		11		ns
Fall Time	$t_F$	$CL=1000\text{pF}$		11		ns
Turn-On Delay Time	$t_{D1}$	Non-inverting Input		34		ns
		Inverting Input		44		ns
Turn-Off Delay Time	$t_{D2}$	Non-inverting Input		34		ns
		Inverting Input		44		ns
<b>Over-temperature protection</b>						
Thermal Shutdown Threshold				150		
Thermal Shutdown ThresholdHysteresis				25		



## Switching Time Test Circuit

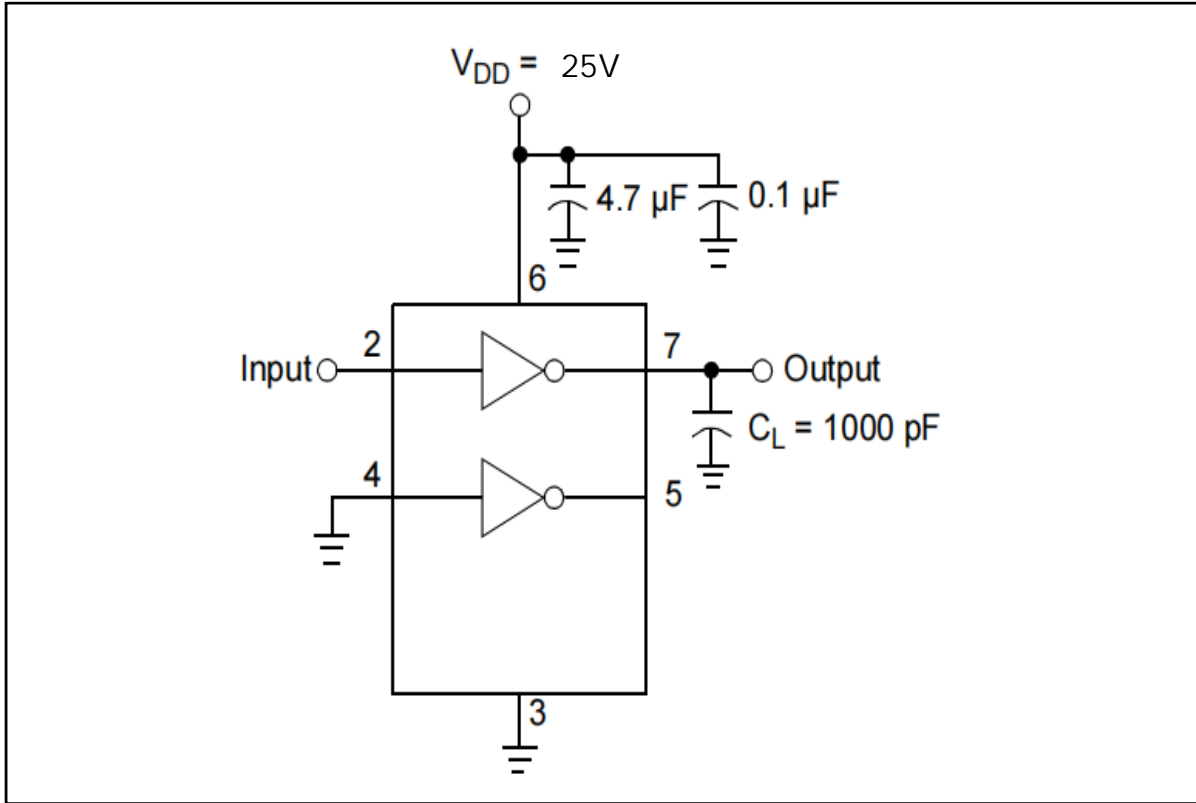

Inverting Driver

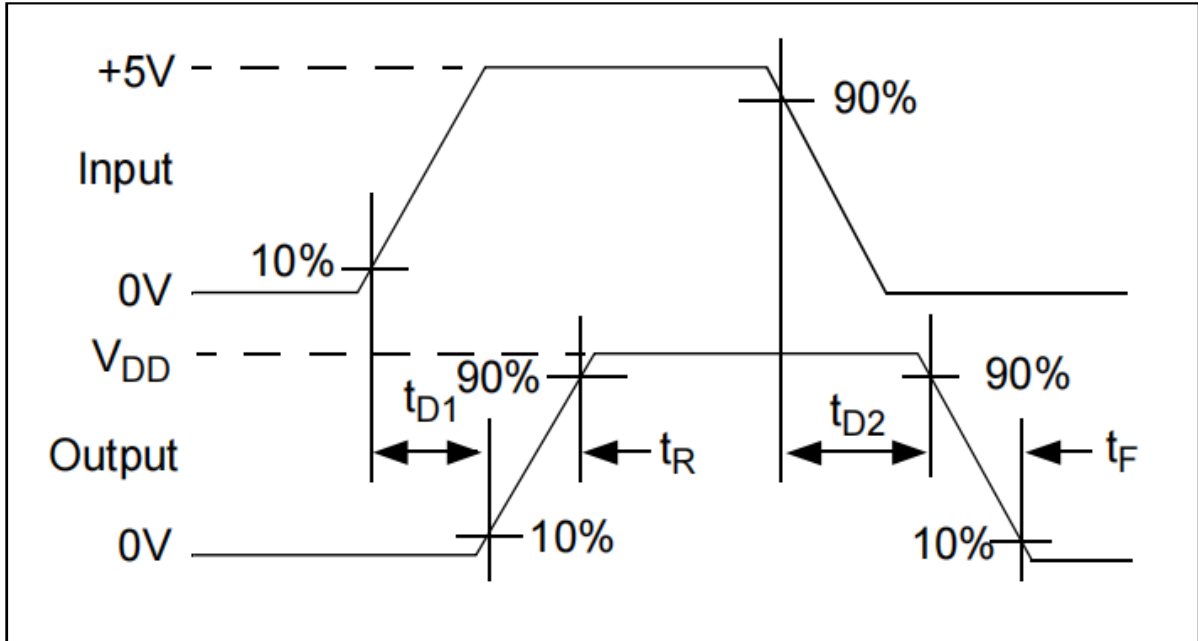

Non-Inverting Driver

## Order information

Order Number	Package	Package Quantity	Marking On The park	Temperature
UCC27323DR-TUDI	SOP8	Tape,Reel,2500	27323	-40°C to 125°C
UCC27323P-TUDI	DIP8	Tube,50,A box of 2000	UCC27323P	
UCC27324DR-TUDI	SOP8	Tape,Reel,2500	27324	
UCC27324P-TUDI	DIP8	Tube,50,A box of 2000	UCC27324P	
UCC27325DR-TUDI	SOP8	Tape,Reel,2500	27325	
UCC27325P-TUDI	DIP8	Tube,50,A box of 2000	UCC27325P	



Package SOP8

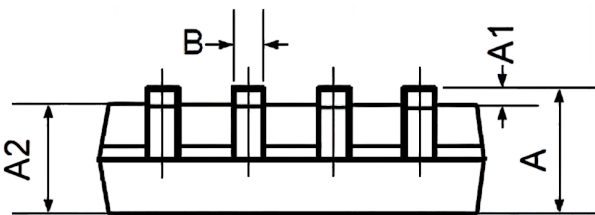

Symbol	Dimensions In Millimeters		Dimensions In Inches	
	Min	Max	Min	Max
A	1.350	1.750	0.053	0.069
A1	0.100	0.250	0.004	0.010
A2	1.350	1.550	0.053	0.061
B	0.330	0.510	0.013	0.020
C	0.190	0.250	0.007	0.010
D	4.780	5.000	0.188	0.197
E	3.800	4.000	0.150	0.157
E1	5.800	6.300	0.228	0.248
e	1.270TYP		0.050TYP	
L	0.400	1.270	0.016	0.050
θ	0°	8°	0°	8°



Package DIP8

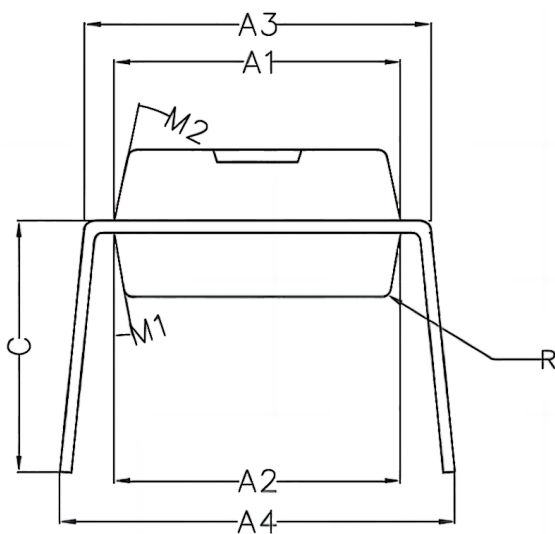
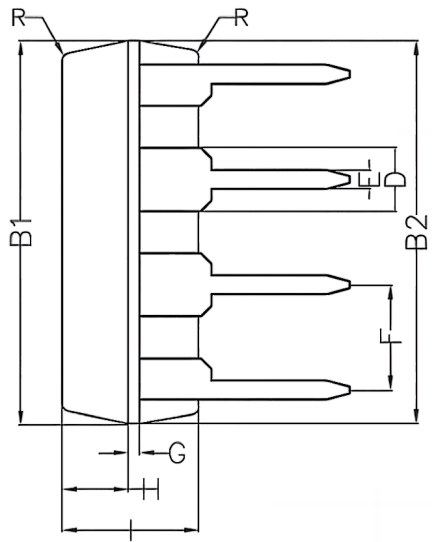
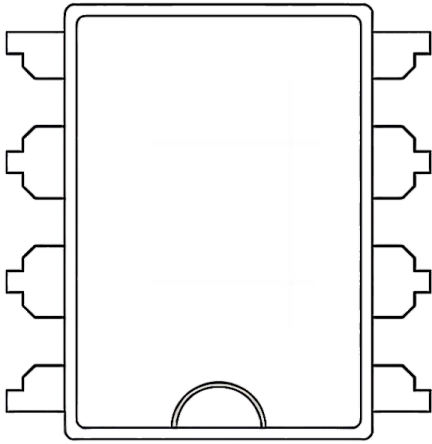

Symbol	Min	Non	Max
A1	6.28	6.33	6.38
A2	6.33	6.38	6.43
A3	7.52	7.62	7.72
A4	7.80	8.40	9.00
B1	9.15	9.20	9.25
B2	9.20	9.25	9.30
C		5.57	
D		1.52	
E	0.43	0.45	0.47
F		2.54	
G		0.25	
H	1.54	1.59	1.64
I	3.22	3.27	3.32
R		0.20	
M1	9°	10°	11°
M2	11°	12°	13°



## Important statement:

- TUDI Semiconductor reserves the right to modify the product manual without prior notice! Before placing an order, customers need to confirm whether the obtained information is the latest version and verify the completeness of the relevant information.
- Any semi-guide product is subject to failure or malfunction under specified conditions. It is the buyer's responsibility to comply with safety standards when using TUDI Semiconductor products for system design and whole machine manufacturing. And take the appropriate safety measures to avoid the potential in the risk of loss of personal injury or loss of property situation!
- TUDI Semiconductor products have not been licensed for life support, military, and aerospace applications, and therefore TUDI Semiconductor is not responsible for any consequences arising from the use of this product in these areas.
- If any or all TUDI Semiconductor products (including technical data, services) described or contained in this document are subject to any applicable local export control laws and regulations, they may not be exported without an export license from the relevant authorities in accordance with such laws.
- The specifications of any and all TUDI Semiconductor products described or contained in this document specify the performance, characteristics, and functionality of said products in their standalone state, but do not guarantee the performance, characteristics, and functionality of said products installed in Customer's products or equipment. In order to verify symptoms and conditions that cannot be evaluated in a standalone device, the Customer should ultimately evaluate and test the device installed in the Customer's product device.
- TUDI Semiconductor documentation is only allowed to be copied without any alteration of the content and with the relevant authorization. TUDI Semiconductor assumes no responsibility or liability for altered documents.
- TUDI Semiconductor is committed to becoming the preferred semiconductor brand for customers, and TUDI Semiconductor will strive to provide customers with better performance and better quality products.