

# LM2901

## DATASHEET

### Specification Revision History:

Version	Date	Description
V1.0	2019/03	New
V1.1	2021/11	Modify Ordering Information
V1.2	2025/02	Modify Ordering Information
V1.3	2025/03	Add application precautions and overall typesetting.

## Description

The LM2901 consists of four independent voltage comparators, designed specifically to operate from a single power supply over a wide voltage range.

## Features

- ※Signal or dual supply operation.
- ※Wide operating supply range( $V_{CC}=2V\sim 30V$ ).
- ※Input common-mode voltage includes ground.
- ※Low supply current drain  $I_{CC}=0.8mA$ (Typical).
- ※Open collector outputs for wired and connection.
- ※Low input bias current  $I_{bias}=25nA$ (Typical).
- ※Low output saturation voltage.
- ※Output compatible with TTL, DTL, and CMOS logic system.

## The appearance of the product

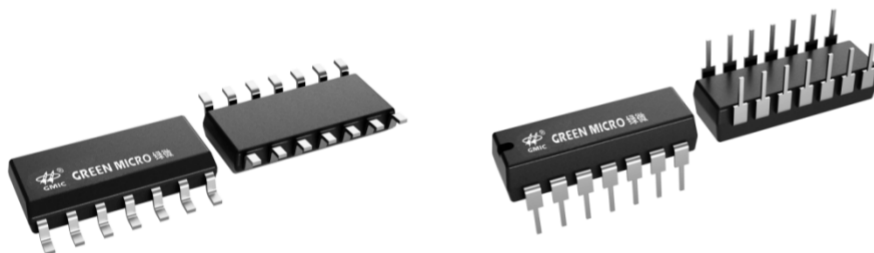

SOP-14

DIP-14

## Ordering Information

Product Model	Package Type	Packing	Packing Qty
LM2901N(GMIC)	DIP-14	TUBE	1000PCS/BOX
LM2901DR(GMIC)	SOP-14	REEL	2500PCS/REEL
LM2901	DIP-14	TUBE	1000PCS/BOX
LM2901	SOP-14	REEL	2500PCS/REEL

## Pin Configurations

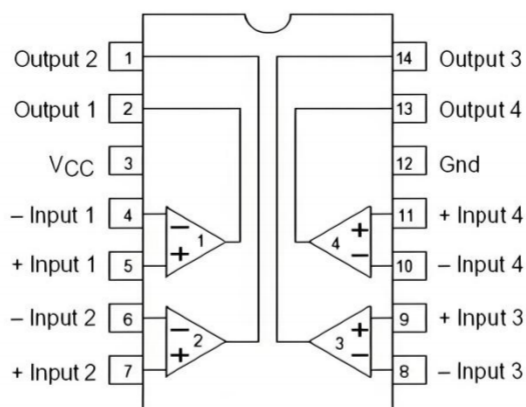

## Block Diagram

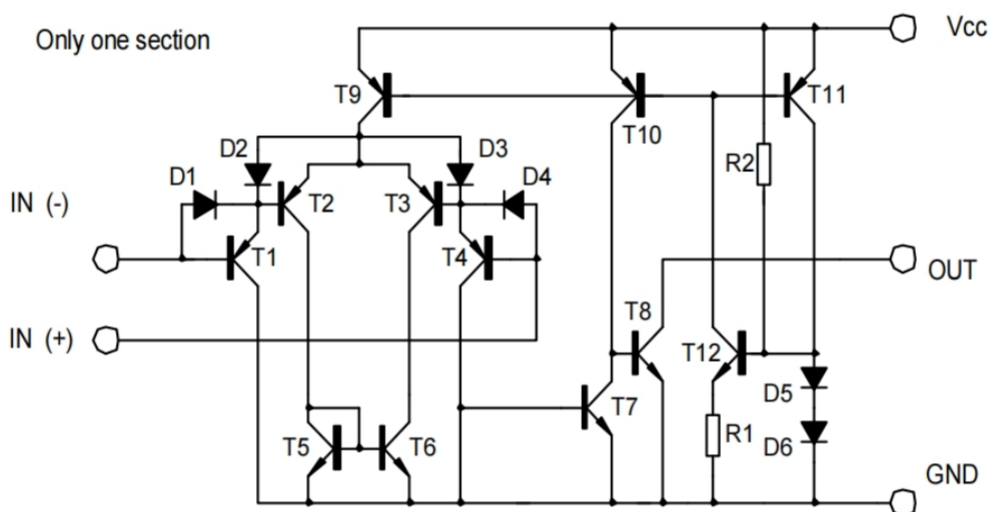

## Absolute Maximum Ratings (Ta=25°C)

PARAMETER	SYMBOL	VALUE	UNIT
Supply Voltage	V <sub>CC</sub>	±15 OR 30	V
Differential input Voltage	V <sub>ID</sub>	30	V
Input Voltage	V <sub>I</sub>	-0.3~30V	V
Power Dissipation	P <sub>d</sub>	570	mW
Operating Temperature	T <sub>opr</sub>	0 to+70	°C
Storage Temperature	T <sub>stg</sub>	-65 to 150	°C

## Electrical Characteristics

(V<sub>cc</sub>=5.0V, T<sub>a</sub>=25°C, All voltage referenced to GND unless otherwise specified)

PARAMETER	SYMBOL	TEST CONDITIONS	MIN	TYP.	MAX	UNIT
Input Offset Voltage	V <sub>IO</sub>	V <sub>CM</sub> =0 to V <sub>cc</sub> -1.5 V <sub>o(p)</sub> =1.4V, R <sub>s</sub> =0		±1.5	±5.0	mV
Input Offset Current	I <sub>IO</sub>			±2.3	±50	nA
Input Bias Current	I <sub>b</sub>			57	200	nA
Input Common-Mode Voltage Range	V <sub>I(R)</sub>		0		V <sub>cc</sub> -1.5	V
Supply Current	I <sub>cc</sub>	R <sub>L</sub> =∞		1.1	2.0	mA
Large Signal Voltage Gain	G <sub>v</sub>	V <sub>cc</sub> =15V, R <sub>L</sub> >15kΩ	50	200		V/mV
Large Signal Response Time	t <sub>res</sub>	V <sub>i</sub> =TTL logic wing V <sub>ref</sub> =1.4V, V <sub>RL</sub> =5V, R <sub>L</sub> =5.1kΩ		350		ns
Response Time	t <sub>res</sub>	V <sub>RL</sub> =5V, R <sub>L</sub> =5.1kΩ		1400		ns
Output Sink Current	I <sub>sink</sub>	V <sub>i(-)</sub> >1V, V <sub>i(+)</sub> =0V, V <sub>o(p)</sub> <1.5V	6	18		mA
Output Saturation Voltage	V <sub>sat</sub>	V <sub>i(-)</sub> >1V, V <sub>i(+)</sub> =0V, I <sub>sink</sub> =4mA		140	400	mV
Output Leakage Current	I <sub>leakage</sub>	V <sub>i(+)</sub> =1V, V <sub>i(-)</sub> =0 V <sub>o(p)</sub> = 5V V <sub>o(p)</sub> =30V		0.1	1.0	nA μA
Differential Input Voltage	V <sub>I(diff)</sub>				32	V

# Typical Performance Characteristics

Fig.1 supply current

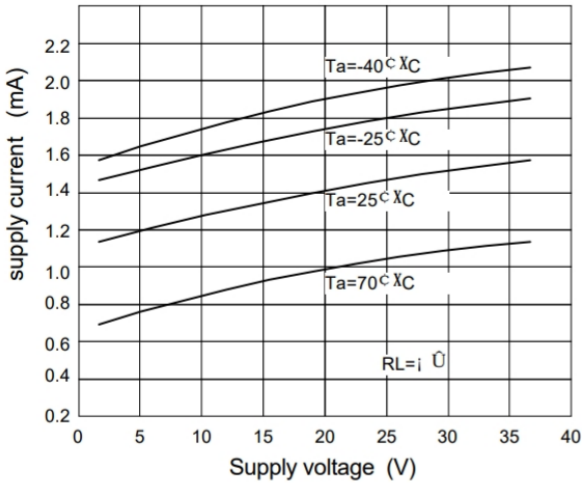

Fig.2 Input current

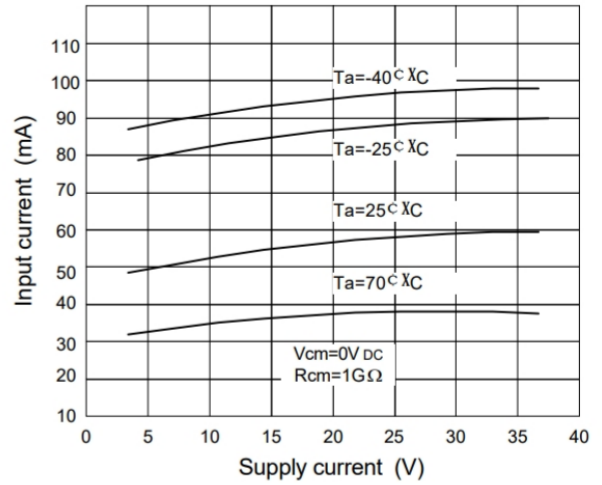

Fig.3 Output saturation voltage

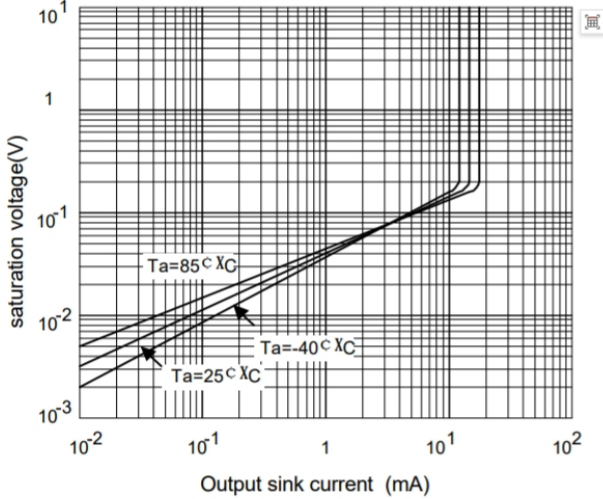

Fig.4 Reponse time for various input overdrive negative transition

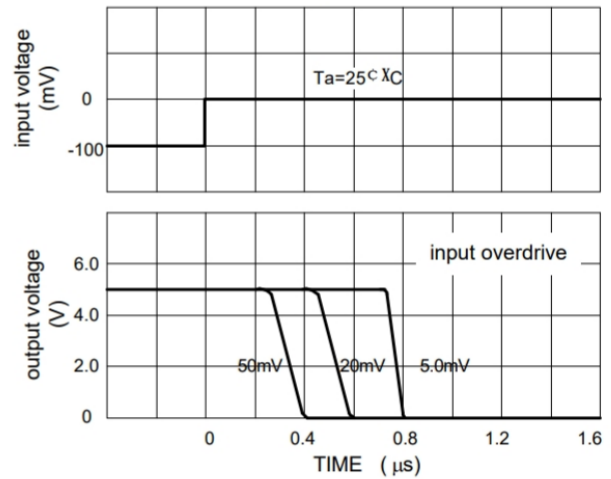

Fig.5 Reponse time for various input overdrive positive transition

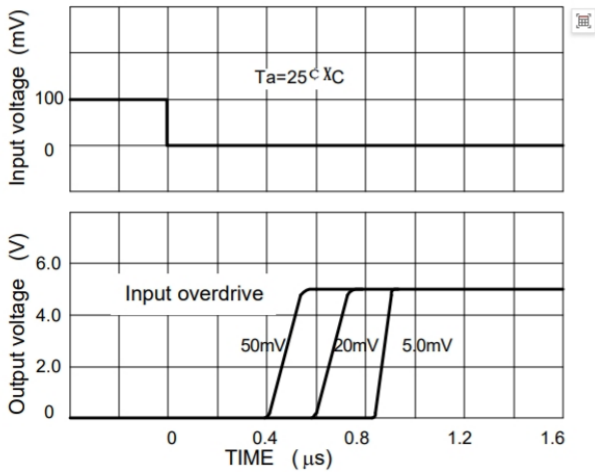

Fig.6

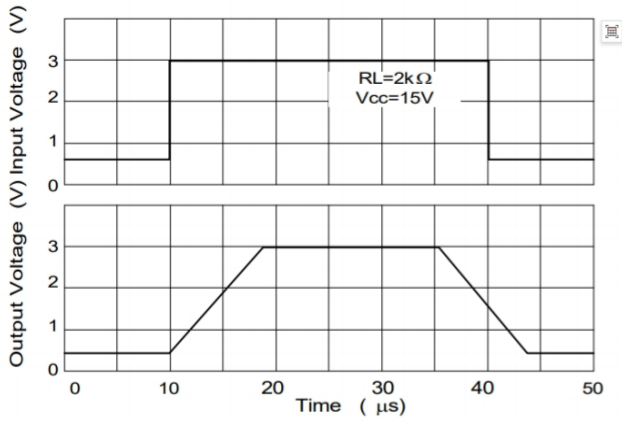

Fig.7 voltage Follower pulse response (small signal)

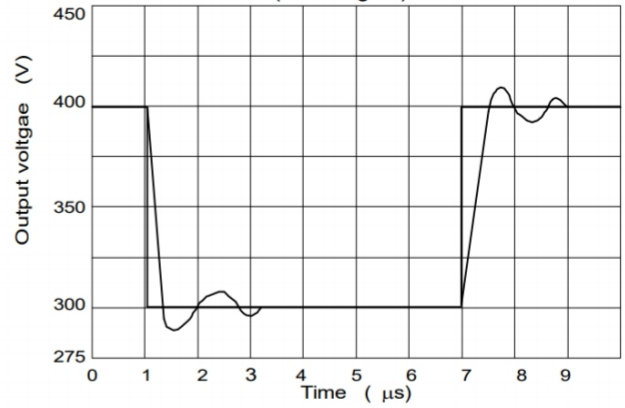

Fig.8 Large signal Frequency Response

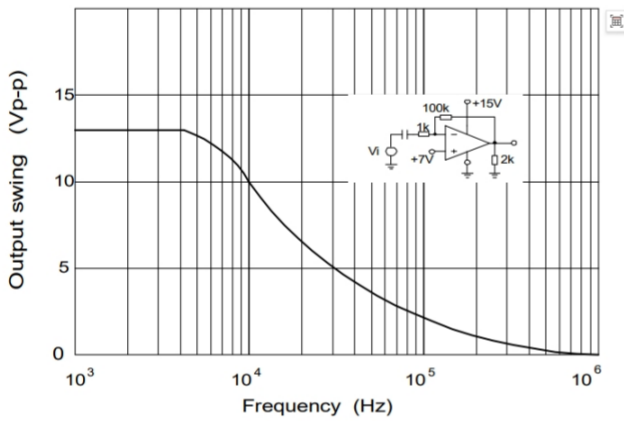

Fig.9 Output Characteristics current sourcing

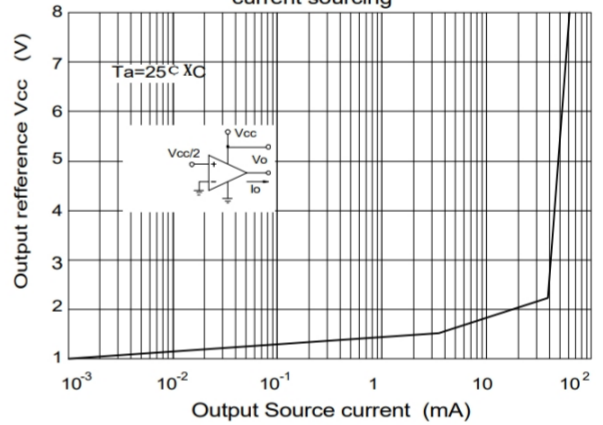

Fig.10 Output Characteristics Current sinking

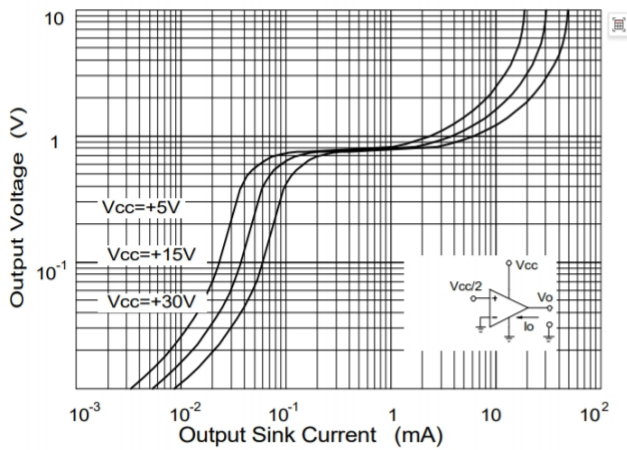
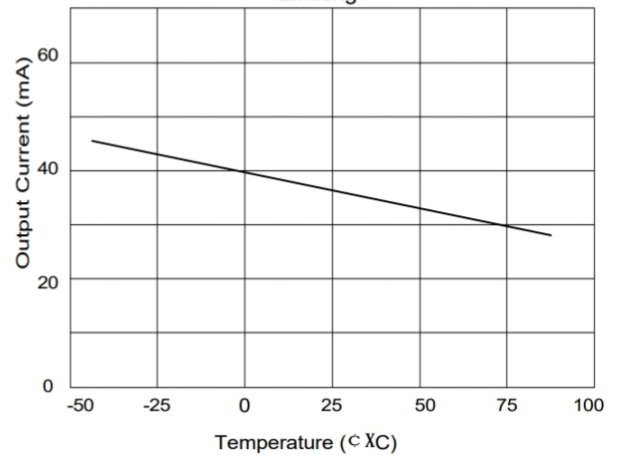
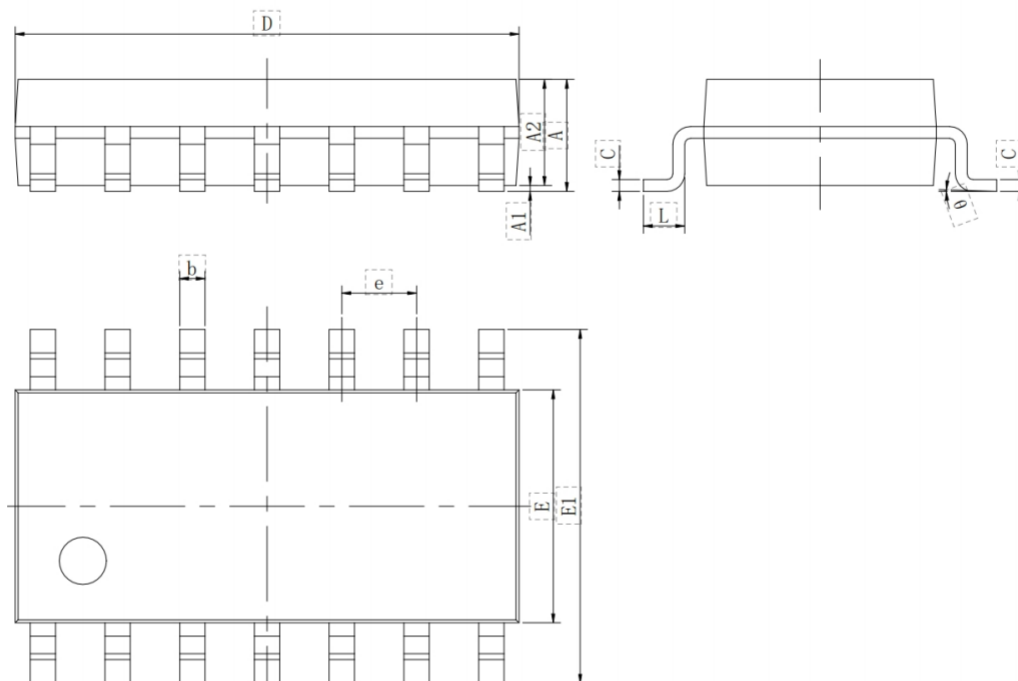

Fig.11 Current Limiting



### Outline Dimensions

#### SOP-14



Symbol	Dimensions In Millimeters		Dimensions In Inches	
	Min	Max	Min	Max
A	1.350	1.750	0.053	0.069
A1	0.100	0.250	0.004	0.010
A2	1.350	1.550	0.053	0.061
b	0.330	0.510	0.013	0.020
c	0.170	0.250	0.007	0.010
D	8.360	8.760	0.329	0.345
E	3.800	4.000	0.150	0.157
E1	5.800	6.200	0.228	0.244
e	1.270(BSC)		0.050(BSC)	
L	0.400	1.270	0.016	0.050
θ	0°	8°	0°	8°

DIP-14

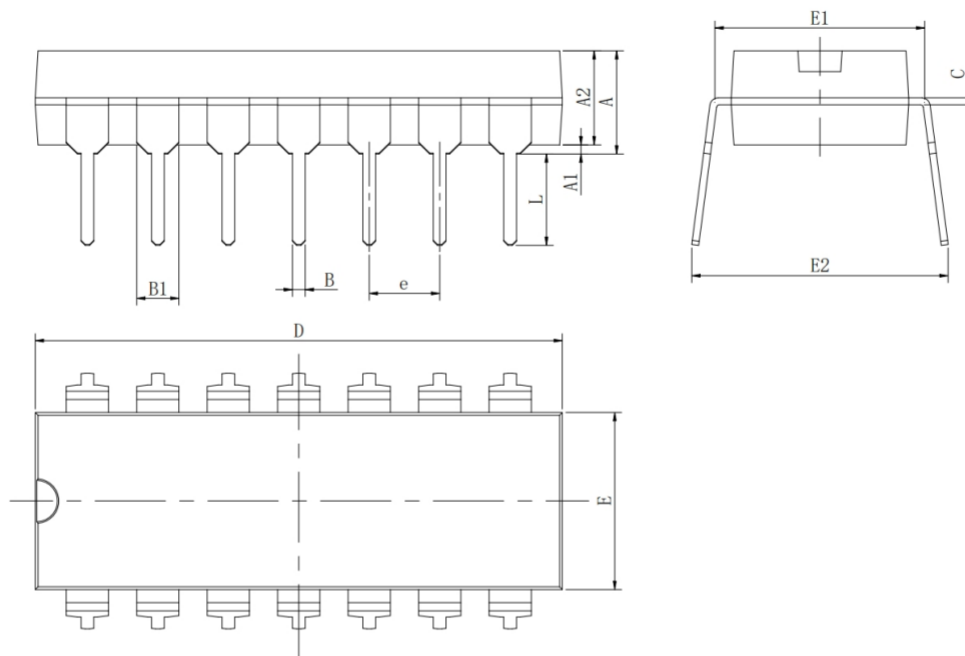

Symbol	Dimensions In Millimeters		Dimensions In Inches	
	Min	Max	Min	Max
A	3.710	4.310	0.146	0.170
A1	0.510		0.020	
A2	3.200	3.600	0.126	0.142
B	0.380	0.570	0.015	0.022
B1	1.524(BSC)		0.060(BSC)	
C	0.204	0.360	0.008	0.014
D	18.800	19.200	0.740	0.756
E	6.200	6.600	0.244	0.260
E1	7.320	7.920	0.288	0.312
e	2.540(BSC)		0.100(BSC)	
L	3.000	3.600	0.118	0.142
E2	8.400	9.000	0.331	0.354

## Important Notice

- Green Micro chip reserves the right to change products and documents without notice. Customers should obtain and verify the completeness of the latest technical information before placing orders. Meanwhile, Green Micro chip shall not assume any responsibility or obligation for non-officially revised documents.
- Any parameters in the entire product specification are for reference only, and actual application testing shall prevail. When customers use the products for system design, they must comply with safety regulations and independently assume the following responsibilities: selecting suitable Green Micro chip products according to application requirements; completing design verification and full-link testing of the application; and ensuring that the application complies with safety regulations or other requirements of the target market. Customers shall bear all personal or property losses caused by design defects or illegal operations, which shall have no relation to Green Micro chip.
- Green Micro chip products are prohibited from being used in scenarios such as life support, military equipment, and key aerospace applications. All accidents and legal liabilities arising from out-of-scope use shall be borne by the user, and Green Micro chip shall not be held responsible.
- All technical resources of Green Micro chip (including data sheets and reference designs) are provided "as is", without guarantee of no defects or universality, and without any express or implied warranties. The documents are only authorized for product development and research described in this document. Unauthorized use of intellectual property, public reproduction, and reverse engineering are strictly prohibited. All claims and losses caused by illegal use shall be borne by the user, and Green Micro chip shall not be liable.