

**MATERIAL: Specification**

Insulator: LCP High Temperature Thermoplastic,UL 94V-0.  
 Contact: Copper Alloy C5210  
 SHELL: SUS304  
 弹片: SUS304  
 弹杆: SUS304

**PLATING:**

Contact: Ni All 50u", Contact area 1u Au", Pad 0.8u Au"  
 Shell: Ni All 50u", Pad Au"

**Electrical:**

Current Rating :0.5mA AC/DC max.  
 Voltage Rating :125V AC/DC  
 Ambient Temperature Range : -25°C~+85°C  
 Storage Temperature Range : -25°C~+85°C  
 Ambient Humidity Range :95% R.H. Max.  
 Contact Resistance:100m max.  
 Insulation Resistance:1000M $\Omega$  min./500VDC  
 Mating Cycles:5,000 Insertions  
 产品耐温温度: 260°C

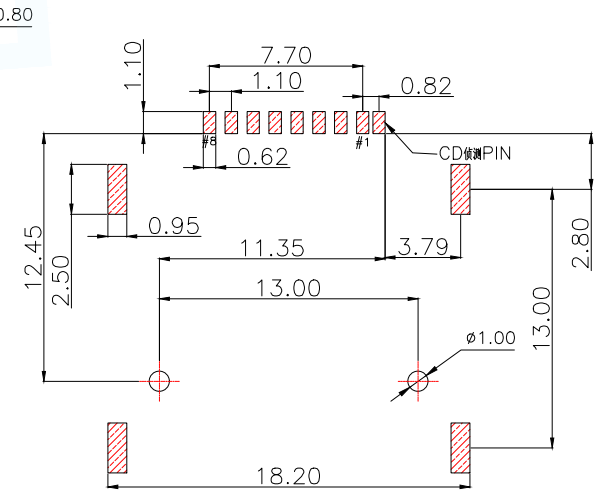
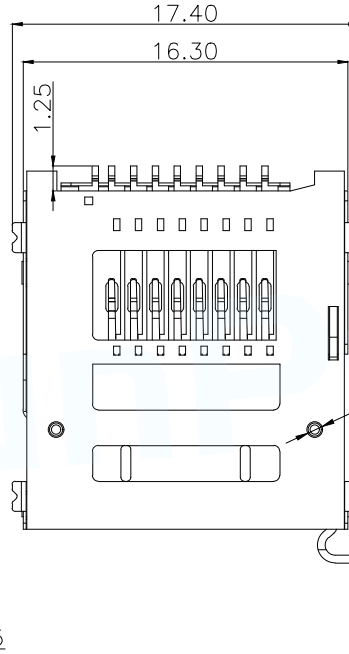
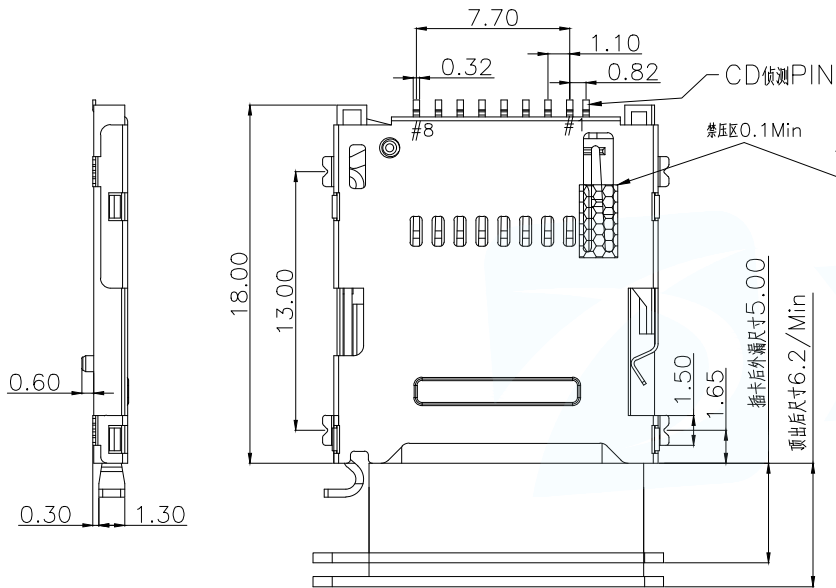

PIN NO.	PIN ASSIGNMENT
1#	DAT2 信号
2#	CD/DAT3 信号
3#	CMD 数据输入
4#	VDD 电压/电源
5#	CLK 时钟
6#	VSS 接地
7#	DAT0 信号
8#	DAT1 信号
CD检测开关	CD 检测端

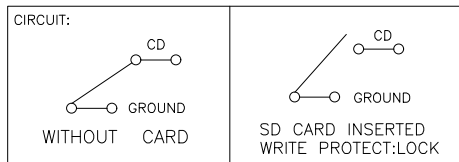

MANUFACTURE DWG		东莞市讯普电子科技有限公司 DongGuan XunPu Electronics Co.,Ltd		
UNLESS OTHERWISE SPECIFIED TOLERANCES			TITLE:TF 卡座PUSH/PUSH 1.75H 带卡座CD检测 XNT Edition	
DECIMALS:	ANGLES:		PAR	TF-112-ACP9
X.:±0.30	X.':±2°		DWN	
X.X:±0.15	X.X':±1°		CHKD	
X.XX:±0.10	X.XX':±0.5°	APVD		
CUSTOMER COPY		SCALE:1:1	UNIT:MM	
		SIZE:A4	SHEET:1F1	
			REV:A	