

# 1. MECHANICAL DIMENSIONS :

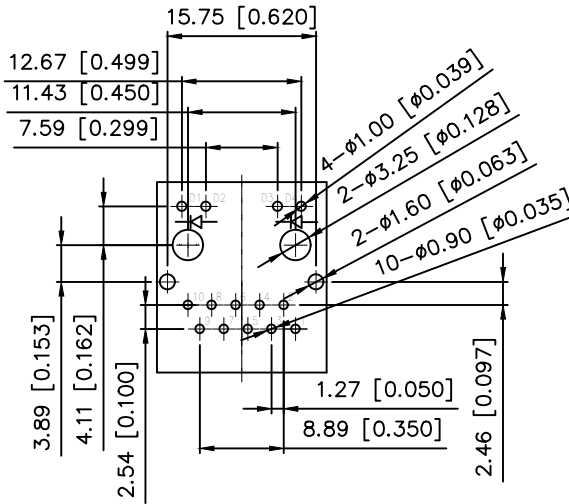

SUGGESTED PCB LAYOUT (TOP VIEW)

## RECOMMENED PLUG DIMENSION:

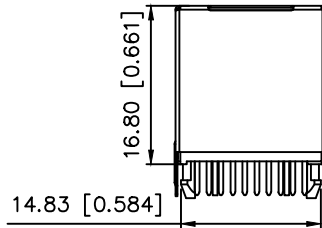
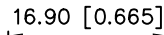
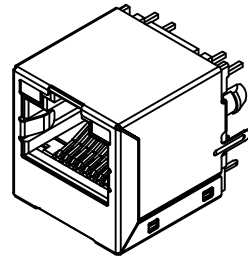
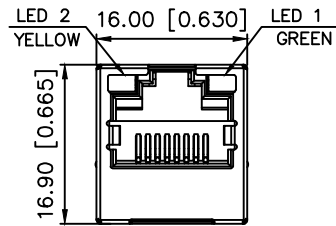
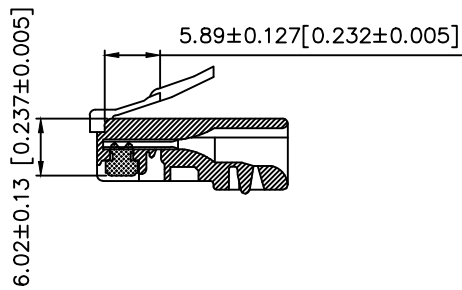

7	8	9
标记 MARK	ECN编号/变更内容 ECN NO/DEFINITION	修改 REVISE
		日期 DATE
		核准 APPROVE

## NOTES:

- MATERIAL:
  - HOUSING: HIGH TEMPERATURE PBT BLACK
  - CONTACTS: T=0.35mm, PHOSPHOR BRONZE, NICKEL 50 $\mu$ MIN UNDERPLATE ON ALL AREA, TIN 80 $\mu$ MIN ON TERMINATION END, GOLD 6U ON CONTACT AREA.
  - SHIELD: T=0.20mm, NICKEL 30 $\mu$ MIN PLATING
- OPERATING TEMPERATURE : 0 $^{\circ}$ C~70 $^{\circ}$ C  
STORAGE TEMPERATURE : -40 $^{\circ}$ C~85 $^{\circ}$ C

3	外壳	铜	镀镍	
2	接触	铜	镀金	
1	基座	PBT	黑色	
序号	品名	材质	电镀/颜色	备注

	深圳市虹成电子有限公司		品名 TITLE	网口
			料号 PART NO	HC-WKQZ-B01C02CH121H
GENERAL TOLERANCES (UNLESS SPECIFIED)		比列 SCALE	1:1	
.0	± 0.50	单位 UNIT	MM	
.00	± 0.38	张数 PART NO	1 OF 1	
.000	± 0.25	审核 CHECKED	夏操云	
ANGLE	± 3 $^{\circ}$	版本 REV	A	批准 APPROVE
				赵亮亮

标记 MARK	ECN编号/变更内容 ECN NO/DEFINITION	修改 REVISE	日期 DATE	核准 APPROVE

### 3. SCHEMATIC:

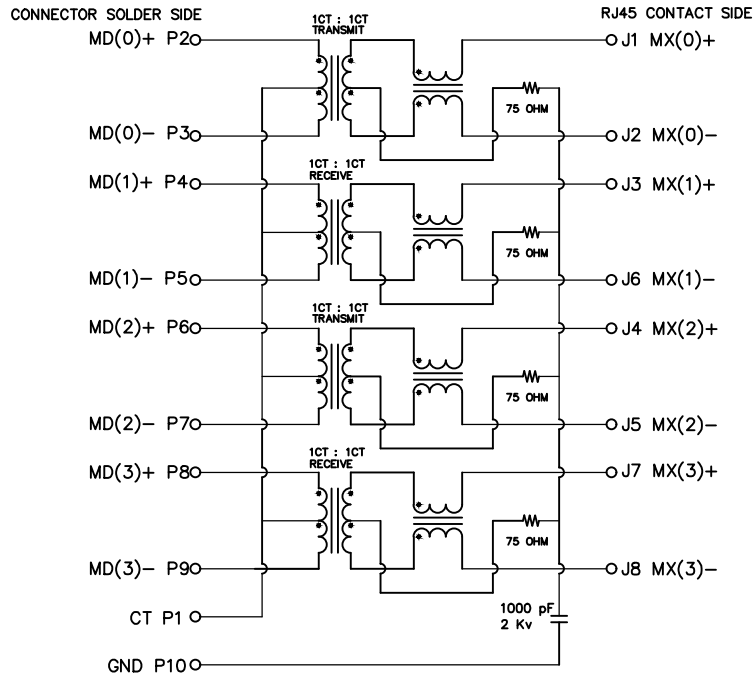

### 4. ELECTRICAL CHARACTERISTICS :

TEST NOTES: (25±5°C)

1.TR: (100KHz,0.1V);  
INPUT TO OUTPUT=1:1±3%

2.LX: (100KHz,100mV,8mA, DC Bias)  
350uH MINIMUM

3.DCR:  
1.2 OHMS MAXIMUM

4.HIPOT:  
INPUT TO OUTPUT=1500VAC FOR 60 SECONDS

5.INSERTION LOSS:  
-1.0dB MAXIMUM AT 0.3MHz TO 100MHz;

6.RETURN LOSS:  
-20dB MINIMUM AT 1MHz TO 30MHz;  
-15dB MINIMUM AT 30MHz TO 60MHz  
-10dB MINIMUM AT 60MHz TO 80MHz

7.CROSS TALK:  
-30dB MINIMUM AT 1MHz TO 100MHz

8.COMMON TO COMMON MODE REJECTION:  
-30dB MINIMUM AT 1MHz TO 100MHz

### 5. LED CONFIGURATION :



	深圳市虹成电子有限公司		品名 TITLE	网口
			料号 PART NO	HC-WKQZ-B01C02CH121H
GENERAL TOLERANCES (UNLESS SPECIFIED)		比列 SCALE	1:1	
.0	± 0.50	单位 UNIT	MM	制图 DRAW
.00	± 0.38	张数 PART NO	1 OF 1	审核 CHECKED
.000	± 0.25	版本 REV	A	批准 APPROVE
ANGLE	± 3.°			夏操云 赵亮亮

