

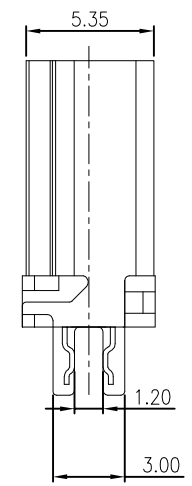

修订 REV NO	标记 MARK	修改摘要 REVISION DESCRIPTION	签名 SIGNATURE	日期 DATE
		NEW DWG		2016-03-12

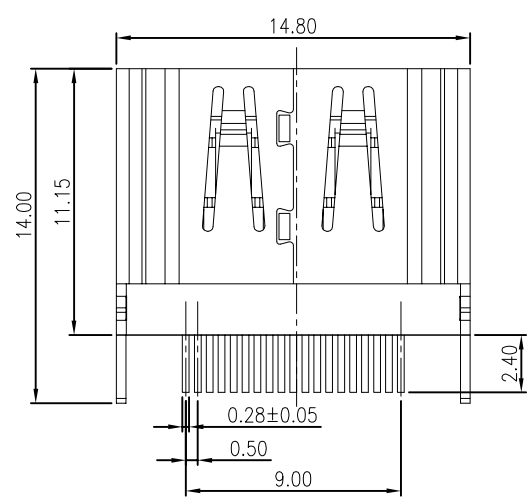
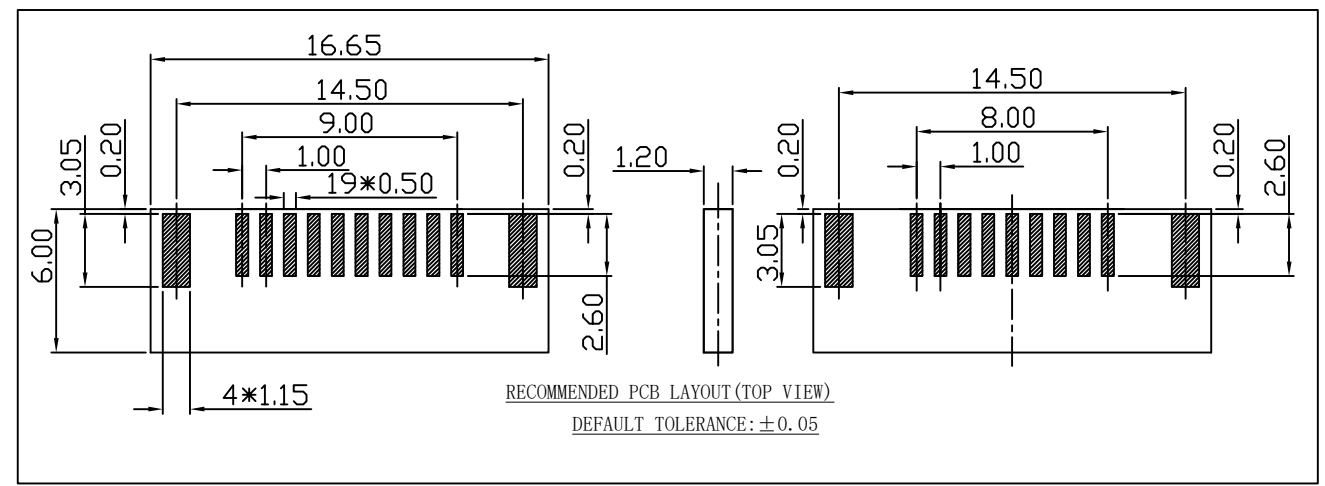
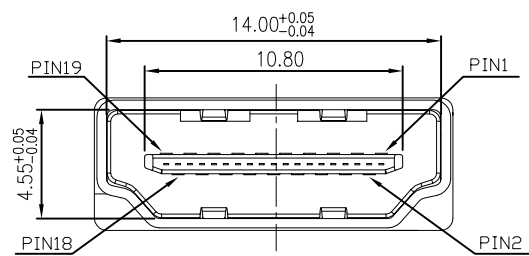

SPECIFICATION

- Electrical characteristics
 - Contact Current Rating: 0.5 A
 - Dielectric Withstanding Voltange: 300V AC
 - Insulation Resistance: a. Mate $100\text{M}\Omega \text{ MIN}$ at 500V/DC
b. Unmate $10\text{M}\Omega \text{ MIN}$ at 150V/DC
 - Contact Resistance: $30\text{m}\Omega \text{ MAX}$
 - Temperature Range: -20° C to $+85^\circ \text{ C}$
- Mechanical
 - Mating Face: 44.1N MAX
 - Unmatin Face: $9.8\text{N MIN}; 39.2\text{N MAX}$
 - Durability: 5000 Cycles
- material:
 - HOUSING: THERMOPLASTICS HIGH TEMP LCP+GLASS
FIBER BLACK COLOR, UL94V-0
 - CONTACT: Copper Alloy , $T=0.20\text{MM}$
 - SHELL: Copper Alloy (SPCC) , $T=0.40\text{MM}$
- PLATING:
 - CONTACT: $1 \sim 30\mu\text{''}$ GOLD/TIN PLATING ON CONTACT AREA
 $100\mu\text{'' MIN}$, TIN PLATING ON SOLDER TAILS
 $50\mu\text{'' MIN}$, NICKEL UNDERPLATING OVER ALL
 - SHELL: $80\mu\text{''}$, NICKEL UNDERPLATING OVER ALL

		深圳市华德共创科技有限公司 Shenzhen Huade co-create Technology Co.,LTD 电话：0755-27111216 传真：0755-29940187						
-TOLERANCES- UNLESS OTHERWISE SPECIFIED 公差参数表		 		TITLE: HDMI AF夹板1.2铁壳0.4镀镍 产品名称: 黑胶弯端				
X.X	± 0.30	X.X*	$\pm 3^\circ$	APPD: 核准:	PART NO: 产品编号: HDMI-GD-132PWB			
X.XX	± 0.20	X.XX*	$\pm 2^\circ$	CHECK: 校对: 王建业	DATE	SCALE	UNIT	CODE NUMBER
X.XXX	± 0.10	X.XXX*	$\pm 1^\circ$	DRAW: 绘图: 黄艳兰	2016-03-12	1:1	mm	A001