

## **AD8551ARZ-HX/AD8552ARZ-HX/AD8554ARZ-HX** **Zero\_Drift, RRIO, CMOS, Op Amps**

### **Description**

The AD8551ARZ-HX/AD8552ARZ-HX/AD8554ARZ-HX series of CMOS operational amplifiers employ auto-zeroing techniques to achieve simultaneously ultra-low input offset voltage (maximum 5  $\mu$ V) and near-zero drift over time and temperature. This amplifier family delivers ultra-low noise, ultra-low offset, and ultra-low power consumption.

These miniature, high-precision operational amplifiers feature high input impedance and rail-to-rail input and output voltage swing. They offer a high gain–bandwidth product of 10 MHz and a slew rate of 5 V/ $\mu$ s.

The devices operate from single or dual supplies ranging from +2.7 V ( $\pm$ 1.35 V) to +5.5 V ( $\pm$ 2.75 V).

The AD8551ARZ-HX/AD8552ARZ-HX/AD8554ARZ-HX are specified for the extended industrial and automotive temperature range of  $-40$  °C to  $+125$  °C.

### **Features**

- ★ Low Offset Voltage: 1 $\mu$ V(TYP)
- ★ Input Offset Drift: 0.005 $\mu$ V/°C
- ★ Low Input Bias Current
- ★ Rail-to-Rail Input and Output
- ★ High Gain, CMRR, PSRR: 130dB(TYP)
- ★ High Gain Bandwidth Product: 10MHz
- ★ High Slew Rate: 5V/ $\mu$ s
- ★ Low Supply Voltage: +2.7V to +5.5V
- ★ Operating Range: -40°C to +125°C

### **Applications**

- ★ Temperature Sensors
- ★ Battery-Powered Instrumentation
- ★ Active Filters
- ★ Weight Scale Sensor
- ★ Power Converter/Inverter

## Pin Configuration

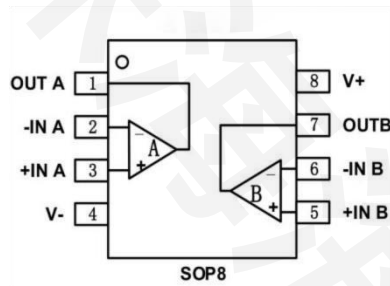

AD8551ARZ-HX

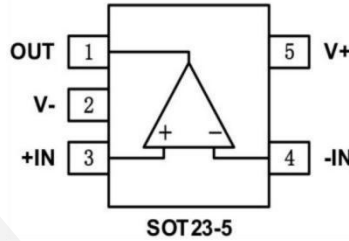

AD8552ARZ-HX

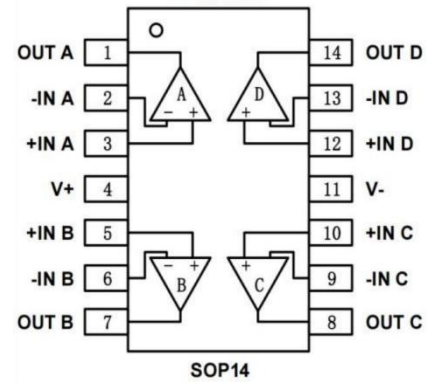

AD8554ARZ-HX

## Absolute Maximum Ratings

Over operating free-air temperature range (unless otherwise noted) <sup>(1)</sup>

PARAMETER	MIN	MAX	UNIT
Supply Voltage, $V_s=(V+) - (V-)$		6	V
Input Terminal Voltage <sup>(2)</sup>	$(V-)-0.5$	$(V+)+0.5$	V
Input Terminal Current <sup>(2)</sup>	-10	+10	mA
Signal Output Current	-35	+35	mA
Maximum Junction Temperature		+150	°C
Storage Temperature Range	-65	+150	°C

**Note 1:** Stresses above these ratings may cause permanent damage. Exposure to absolute maximum conditions for extended periods may degrade device reliability. These are stress ratings only, and functional operation of the device at these or any other conditions beyond those specified is not implied.

**Note 2:** Input terminals are diode-clamped to the power-supply rails. Input signals that can swing more than 0.5V beyond the supply rails should be current-limited to 10mA or less.

## ESD Ratings

SYMBOL	PARAMETER		VALUE	UNIT
V(ESD)	Electrostatic discharge	Human-body model (HBM)	±2000	V

## Recommended Operating Conditions

Over operating free-air temperature range (unless otherwise noted)

PARAMETER	MIN	TYP	MAX	UNIT
Supply Voltage, $V_s=(V+) - (V-)$	Signal-supply	2.7	5.5	V
	Dual-supply	±1.35	±2.75	V
Operating Temperature Range	-40	+25	+125	°C

## Electrical characteristics

(At  $T_A=+25^\circ\text{C}$ ,  $V_S=5\text{V}$ ,  $R_L=10\text{k}\Omega$  connected to  $V_S/2$ , and  $V_{\text{OUT}}=V_S/2$ , unless otherwise noted.)

PARAMETER	SYMBOL	CONDITIONS	MIN	TYP	MAX	UNIT
<b>POWER SUPPLY</b>						
Operating Voltage Range	$V_S$		2.7		5.5	V
Quiescent Current/Amplifier	$I_Q$			700		$\mu\text{A}$
Power-Supply Rejection Ratio	PSRR	$V_S=2.7\text{V to }5.5\text{V}$ , $V_{\text{CM}}=0\text{V}$	110	130		dB
<b>INPUT</b>						
Input Offset Voltage	$V_{\text{OS}}$	$V_{\text{CM}}=V_S/2$		$\pm 1$	$\pm 5$	$\mu\text{V}$
Input Offset Voltage Average Drift	$dV_{\text{OS}}/dT$			0.005		$\mu\text{V}/^\circ\text{C}$
Input Bias Current	$I_B$	$V_{\text{CM}}=V_S/2$		$\pm 50$		$\text{pA}$
Input Offset Current	$I_{\text{OS}}$	$V_{\text{CM}}=V_S/2$		$\pm 10$		$\text{pA}$
Common-Mode Voltage Range	$V_{\text{CM}}$		$(V_-)-0.1$		$(V_+)+0.1$	V
Common-Mode Rejection Ratio	CMRR	$(V_-)-0.1\text{V} < V_{\text{CM}} < (V_+)+0.1\text{V}$	110	130		dB
Input Differential Capacitance				1		$\text{pF}$
Input Common Capacitance				5		$\text{pF}$
<b>OUTPUT</b>						
Open-Loop Voltage Gain	$A_{\text{OL}}$	$R_L=10\text{K}\Omega$ , $V_O=0.3\text{V to }4.7\text{V}$	110	130		dB
Output Voltage High	$V_{\text{OH}}$	$R_L=100\text{K}\Omega$ to GND	4.99	4.998		V
		$R_L=10\text{K}\Omega$ to GND	4.95	4.98		V
Output Voltage Low	$V_{\text{OL}}$	$R_L=100\text{K}\Omega$ to $V_+$		1	10	mV
		$R_L=10\text{K}\Omega$ to $V_+$		10	30	mV
Short-Circuit Current	$I_{\text{OUT}}$			35		mA
<b>FREQUENCY RESPONSE</b>						
Slew Rate	SR	$G=+1$		5		$\text{V}/\mu\text{s}$
Gain-Bandwidth Product	GBW			10		MHz
Overload Recovery Time				1		$\mu\text{s}$
<b>NOISE</b>						
Input Voltage Noise	$e_{\text{n-p}}$	$f=0.01\text{Hz to }10\text{Hz}$		0.75		$\mu\text{Vpp}$
		$f=0.01\text{Hz to }1\text{Hz}$		0.22		$\mu\text{Vpp}$
Input Voltage Noise Density	$e_n$	$f=1\text{KHz}$		35		$\text{nV}/\sqrt{\text{Hz}}$

## Typical characteristics

At  $T_A=+25^{\circ}\text{C}$ ,  $V_s=5\text{V}$ ,  $R_L = 10\text{k}\Omega$  connected to  $V_s/2$ ,  $V_{OUT}=V_s/2$ , unless otherwise noted.

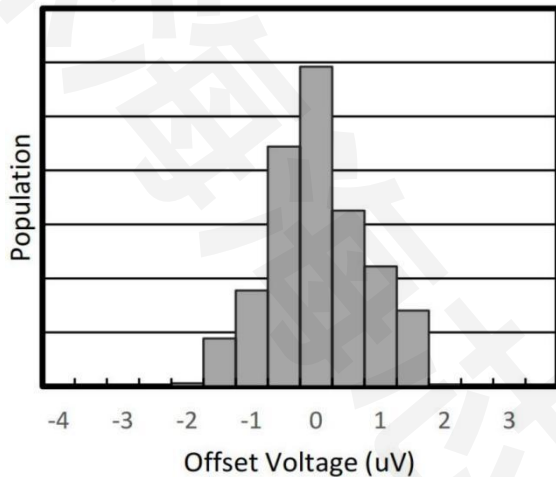

Figure 1. Offset Voltage Production Distribution

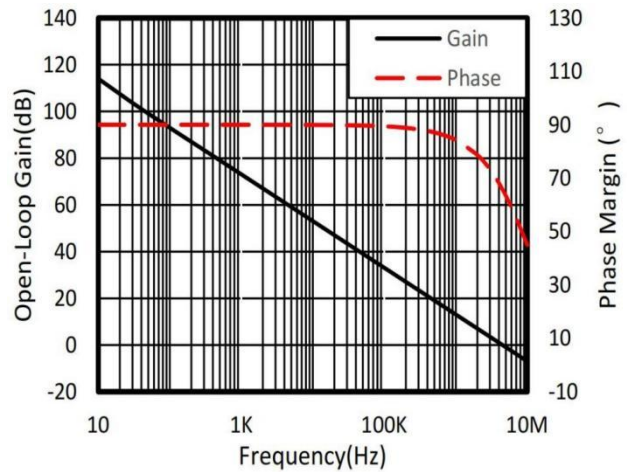

Figure 2. Open-Loop Gain And Phase vs Frequency

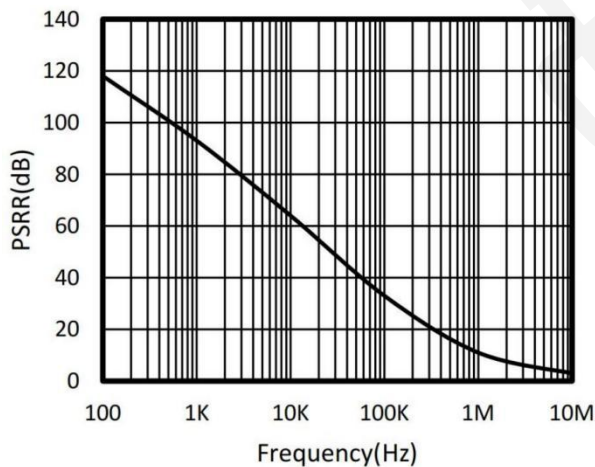

Figure 3. Power-Supply Rejection Ratio vs Frequency

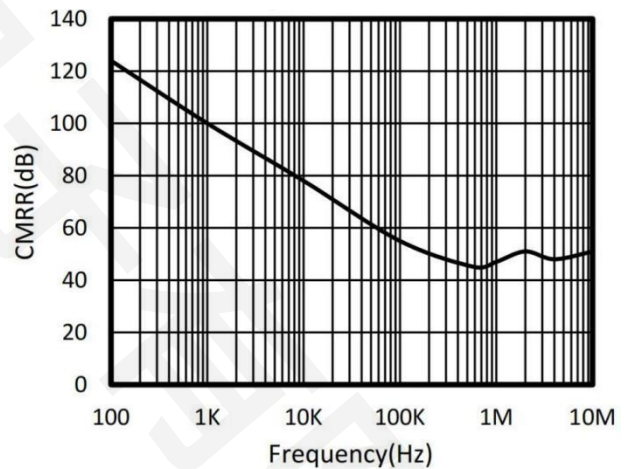

Figure 4. Common-Mode Rejection Ratio vs Frequency

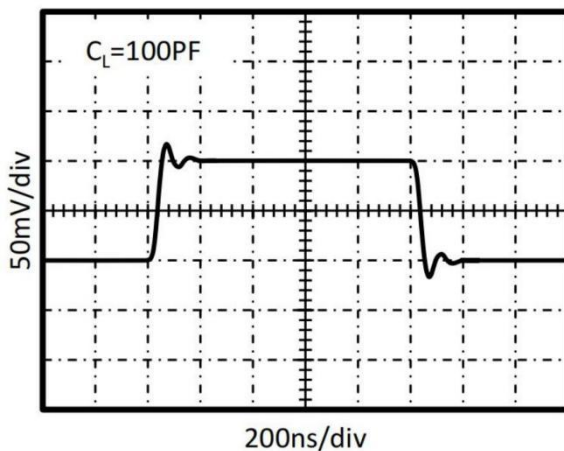

Figure 5. Small-Signal Step Response

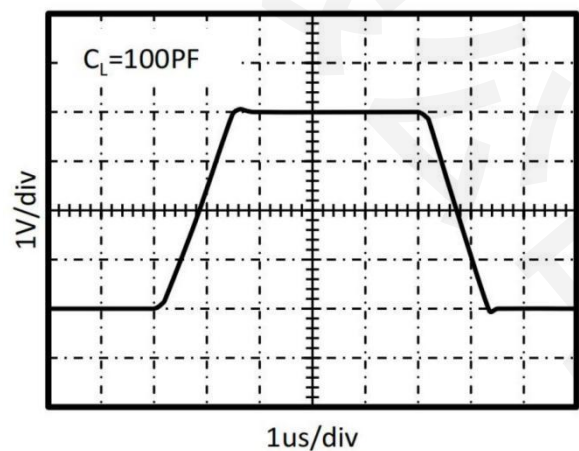
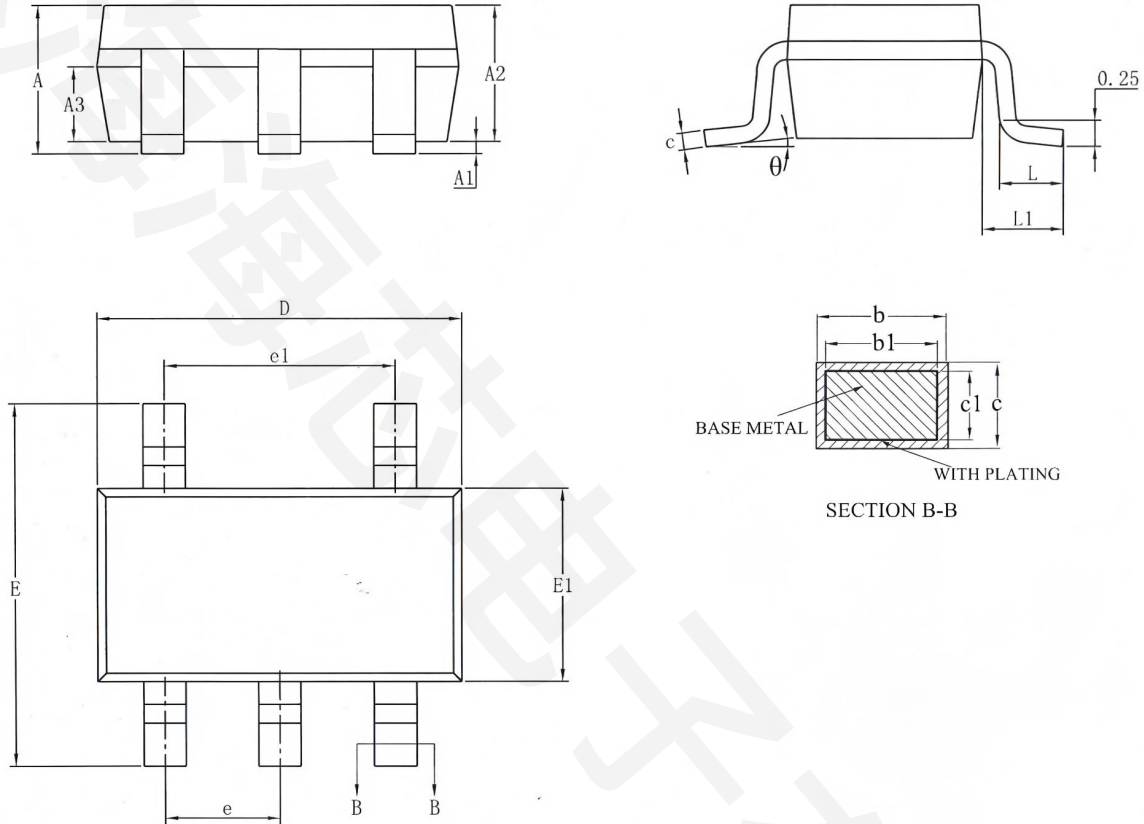

Figure 6. Large-Signal Step Response

## Package outline dimensions

AD8552ARZ-HX  
SOT23-5



SYMBOL	MILLIMETER		
	MIN	NOM	MAX
A	—	—	1.25
A1	0.04	—	0.10
A2	1.00	1.10	1.20
A3	0.60	0.65	0.70
b	0.33	—	0.41
b1	0.32	0.35	0.38
C	0.15	—	0.19
c1	0.14	0.15	0.16
D	2.82	2.92	3.02
E	2.60	2.80	3.00
E1	1.50	1.60	1.70
e	0.95BSC	—	—
e1	1.90BSC	—	—
L	0.30	—	0.60
L1	—	0.60REF	—
$\theta$	0	—	8°

AD8551ARZ-HX  
SOP-8

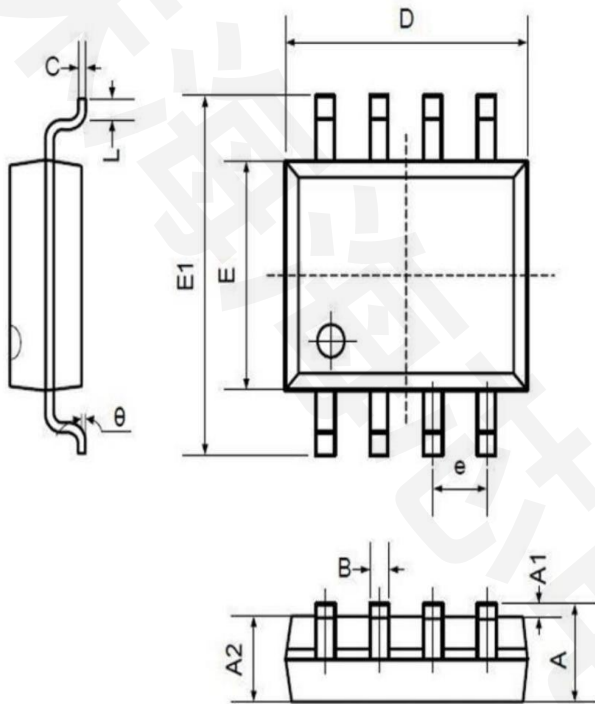

Symbol	Dimensions In Millimeters		Dimensions In Inches	
	Min	Max	Min	Max
A	1.350	1.750	0.053	0.069
A1	0.100	0.250	0.004	0.010
A2	1.350	1.550	0.053	0.061
B	0.330	0.510	0.013	0.020
C	0.190	0.250	0.007	0.010
D	4.780	5.000	0.188	0.197
E	3.800	4.000	0.150	0.157
E1	5.800	6.300	0.228	0.248
e	1.270TYP		0.050TYP	
L	0.400	1.270	0.016	0.050
θ	0°	8°	0°	8°

AD8554ARZ-HX  
SOP14

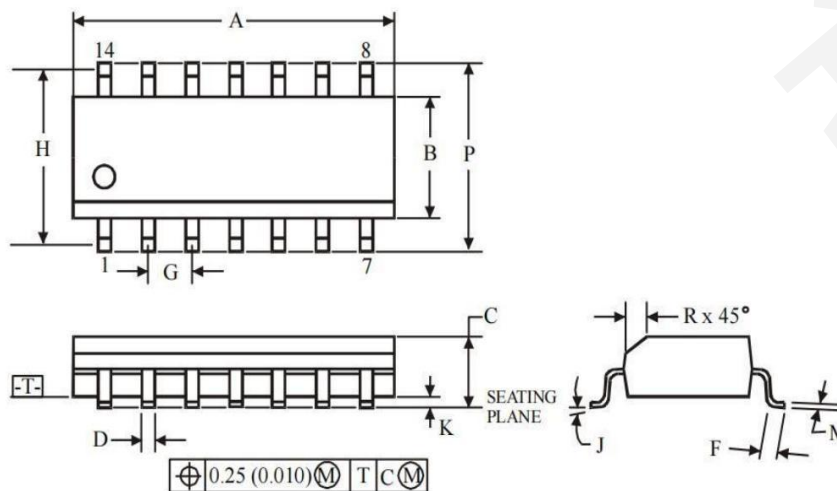

Symbol	Dimension, mm	
	MIN	MAX
A	8.55	8.75
B	3.8	4
C	1.35	1.75
D	0.33	0.51
F	0.4	1.27
G	1.27	
H	5.27	
J	0°	8°
K	0.1	0.25
M	0.19	0.25
P	5.8	6.2
R	0.25	0.5

NOTES:

- Dimensions A and B do not include mold flash or protrusion.
- Maximum mold flash or protrusion 0.15 mm (0.006) per side for A; for B - 0.25 mm (0.010) per side.