

Product Summary

- V_{DS} 80V
- I_D 70A
- $R_{DS(ON)}$ (at $V_{GS}=10V$) $<7.0m\Omega$
- 100% EAS Tested
- 100% ∇V_{DS} Tested

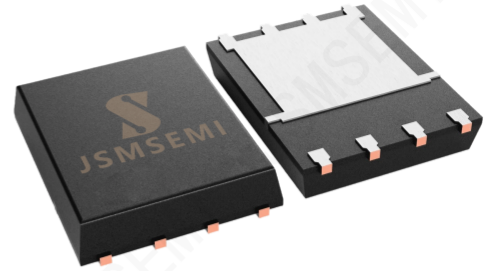

General Description

- Split gate trench MOSFET technology
- Excellent package for heat dissipation
- High density cell design for low $R_{DS(ON)}$
- Moisture Sensitivity Level 1
- Epoxy Meets UL 94 V-0 Flammability Rating
- Halogen Free

Applications

- Power switching application
- Uninterruptible power supply
- DC-DC convertor
- Motor drivers

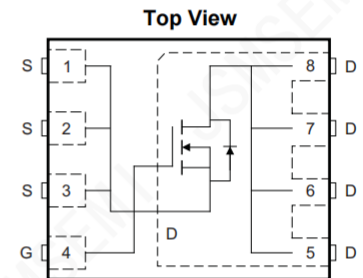

■ Absolute Maximum Ratings ($T_A=25^\circ C$ unless otherwise noted)

Parameter		Symbol	Limit	Unit
Drain-source Voltage		V_{DS}	80	V
Gate-source Voltage		V_{GS}	± 20	V
Drain Current	$T_C=25^\circ C$	I_D	70	A
	$T_C=100^\circ C$		50	
Pulsed Drain Current ^A		I_{DM}	280	A
Avalanche energy ^B		EAS	580	mJ
Total Power Dissipation ^C	$T_C=25^\circ C$	P_D	154	W
	$T_C=100^\circ C$		100	
Junction and Storage Temperature Range		T_J, T_{STG}	-55~+150	$^\circ C$

■ Thermal resistance

Parameter		Symbol	Typ	Max	Units
Thermal Resistance Junction-to-Ambient ^D	Steady-State	$R_{\theta JA}$	45		$^\circ C/W$
Thermal Resistance Junction-to-Case	Steady-State	$R_{\theta JC}$	1.0		

Ordering Information

Order number	Package	Marking	Operation Temperature Range	MSL Grade	Ship, Quantity	Green
BSC072N08NS5-JSM	DFN5060-8L	072N08NS	-55 to 150 $^\circ C$	1	T&R,5000	RoHS

■ Electrical Characteristics ($T_J=25^\circ\text{C}$ unless otherwise noted)

Parameter	Symbol	Conditions	Min	Typ	Max	Units
Static Parameter						
Drain-Source Breakdown Voltage	BV_{DSS}	$V_{GS}=0V, I_D=250\mu A$	100	-	-	V
		$V_{GS}=0V, I_D=1mA$	100	-	-	V
Zero Gate Voltage Drain Current	I_{DSS}	$V_{DS}=100V, V_{GS}=0V$	-	-	1	μA
		$V_{DS}=100V, V_{GS}=0V, T_J=150^\circ C$	-	-	100	
Gate-Body Leakage Current	I_{GSS}	$V_{GS}=\pm 20V, V_{DS}=0V$	-	-	± 100	nA
Gate Threshold Voltage	$V_{GS(th)}$	$V_{DS}=V_{GS}, I_D=250\mu A$	2.0	-	4.0	V
Static Drain-Source On-Resistance	$R_{DS(on)}$	$V_{GS}=10V, I_D=20A$	-	6.0	7.0	m Ω
Diode Forward Voltage	V_{SD}	$I_S=50A, V_{GS}=0V$	-	-	1.2	V
Gate resistance	R_G	f=1MHz	-	1.7	-	Ω
Maximum Body-Diode Continuous Current	I_S		-	-	70	A
Dynamic Parameters						
Input Capacitance	C_{iss}	$V_{DS}=50V, V_{GS}=0V, f=1MHz$	-	3920	-	μF
Output Capacitance	C_{oss}		-	590	-	
Reverse Transfer Capacitance	C_{rss}		-	20	-	
Switching Parameters						
Total Gate Charge	Q_g	$V_{GS}=10V, V_{DS}=80V, I_D=20A$	-	59	-	nC
Gate-Source Charge	Q_{gs}		-	18	-	
Gate-Drain Charge	Q_{gd}		-	15	-	
Reverse Recovery Charge	Q_{rr}	$I_F=1A, di/dt=100A/\mu s$	-	53	-	nC
Reverse Recovery Time	t_{rr}		-	55	-	ns
Turn-on Delay Time	$t_{D(on)}$	$V_{GS}=10V, V_{DD}=50V, I_D=50A$ $R_{GEN}=10\Omega$	-	24	-	ns
Turn-on Rise Time	t_r		-	105	-	
Turn-off Delay Time	$t_{D(off)}$		-	57	-	
Turn-off fall Time	t_f		-	74	-	

A. Repetitive rating; pulse width limited by max. junction temperature.

 B. $T_J=25^\circ\text{C}$, $V_G=10V$, $R_G=25\Omega$, $L=0.5\text{mH}$

 C. P_d is based on max. junction temperature, using junction-case and junction-ambient thermal resistance.

■ Typical Electrical and Thermal Characteristics Diagrams

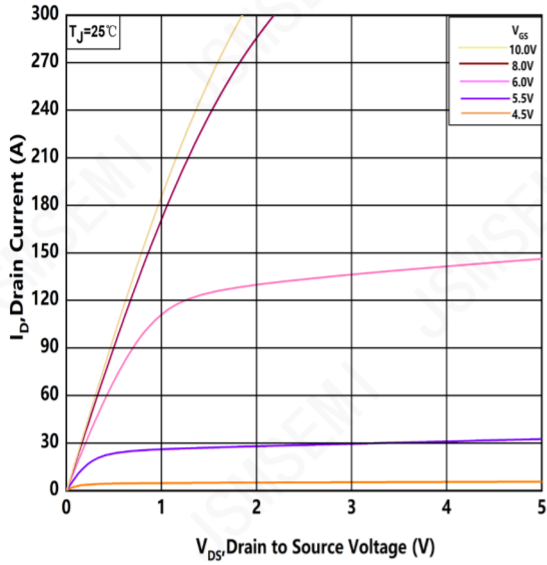

Figure.1 Output Characteristics $T_j=25^\circ\text{C}$

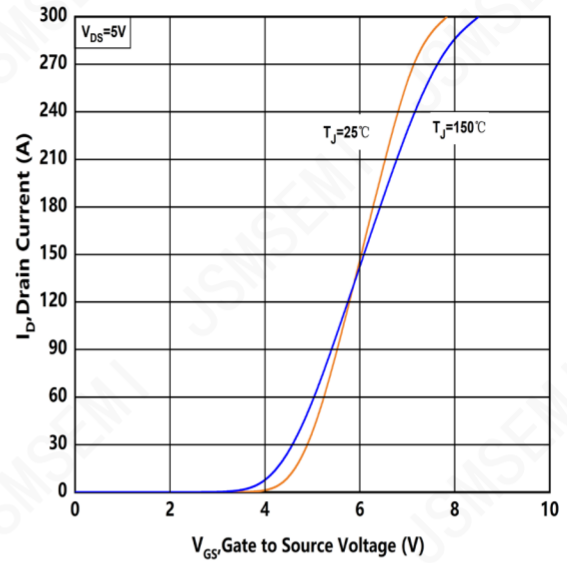

Figure.2 Transfer Characteristic for Various Junction Temperatures

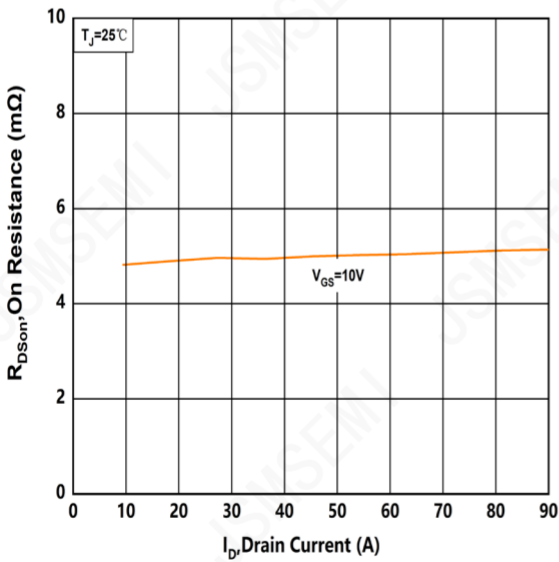

Figure.3 On-Resistance vs Drain Current For Various Gate Voltage

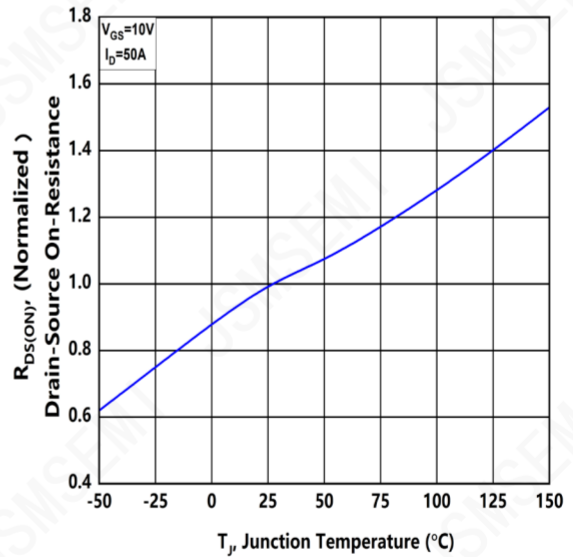

Figure.4 Typical On-Resistance vs Junction Temperature

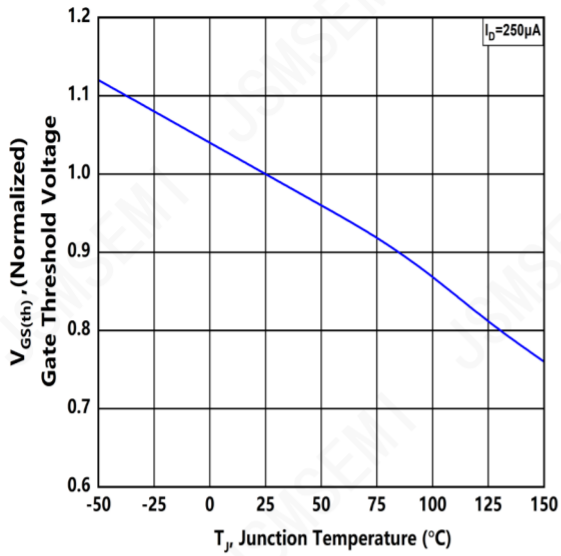

Figure.5 Typical Threshold Voltage vs Junction Temperature

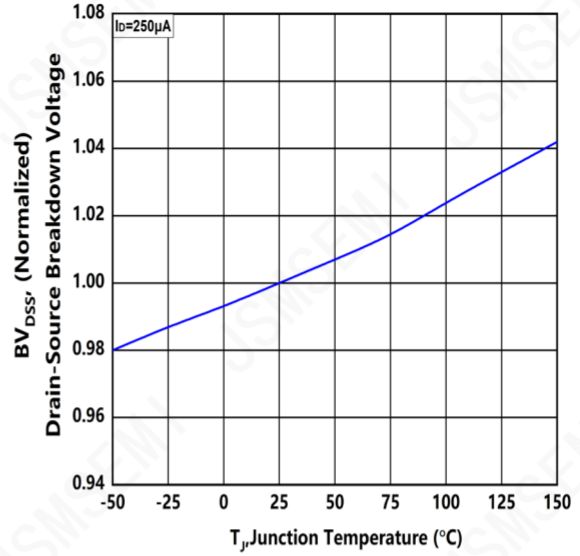

Figure.6 Typical Breakdown Voltage vs Junction Temperature

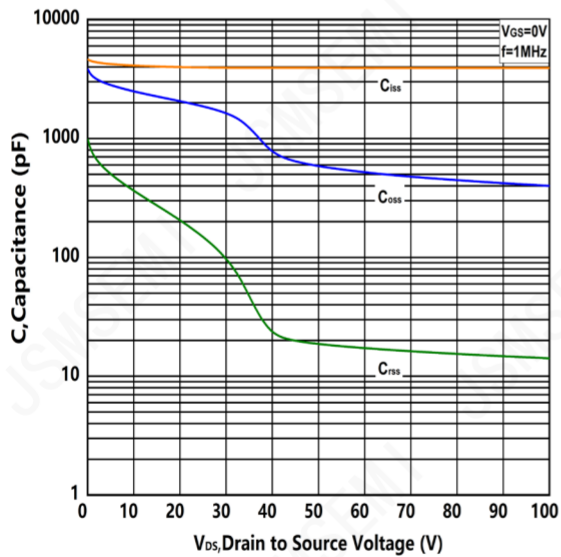

Figure.7 Typical Capacitance vs Drain to Source Voltage

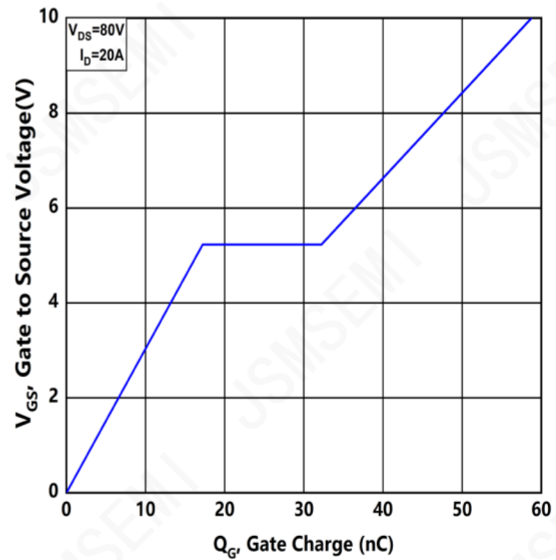

Figure.8 Typical Gate Charge vs Gate to Source Voltage

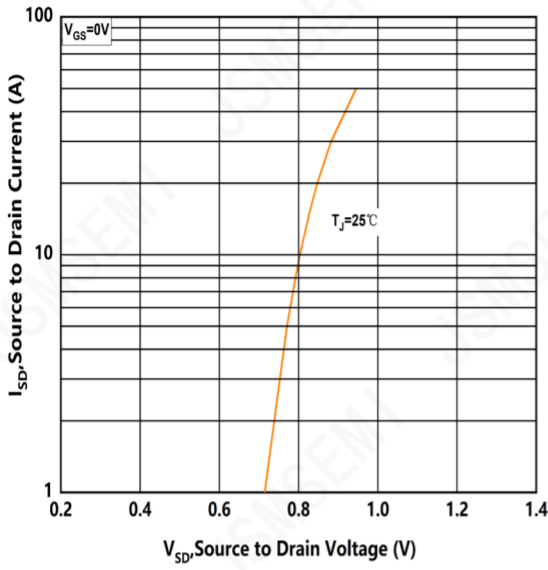

Figure.9 Typical Body Diode Characteristics

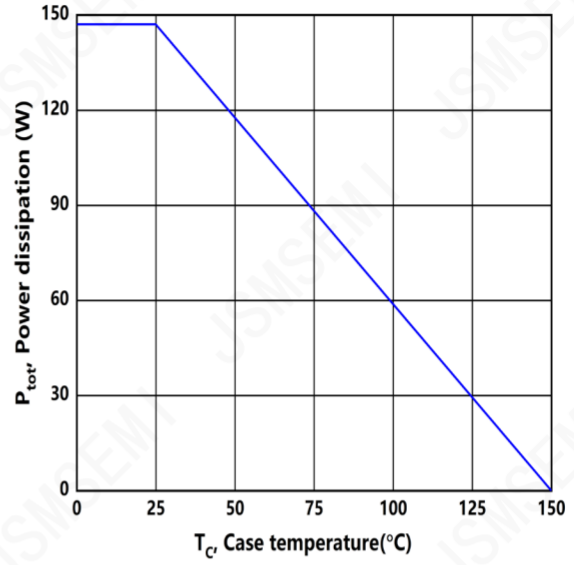

Figure.10 Maximum power Dissipation Derating vs Case Temperature

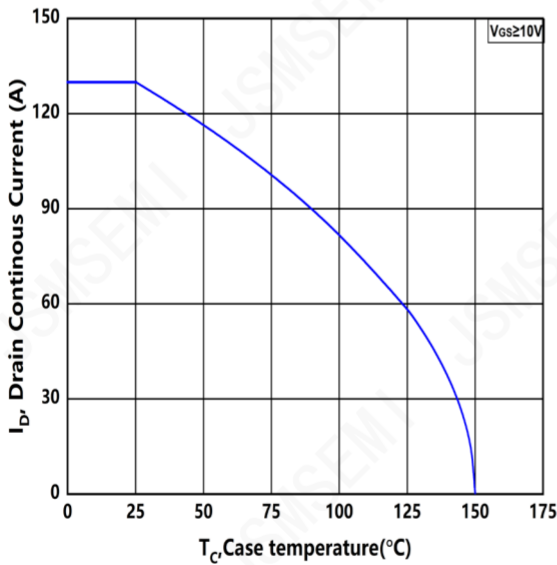

Figure.11 Continuous Drain Current Derating vs Case Temperature

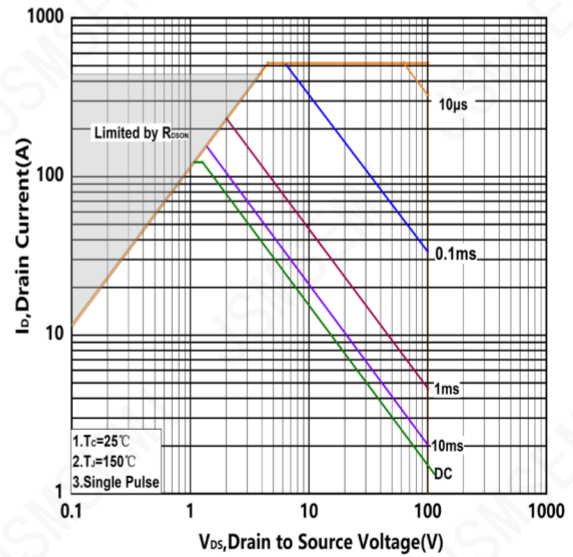

Figure.12 Safe Operating Area

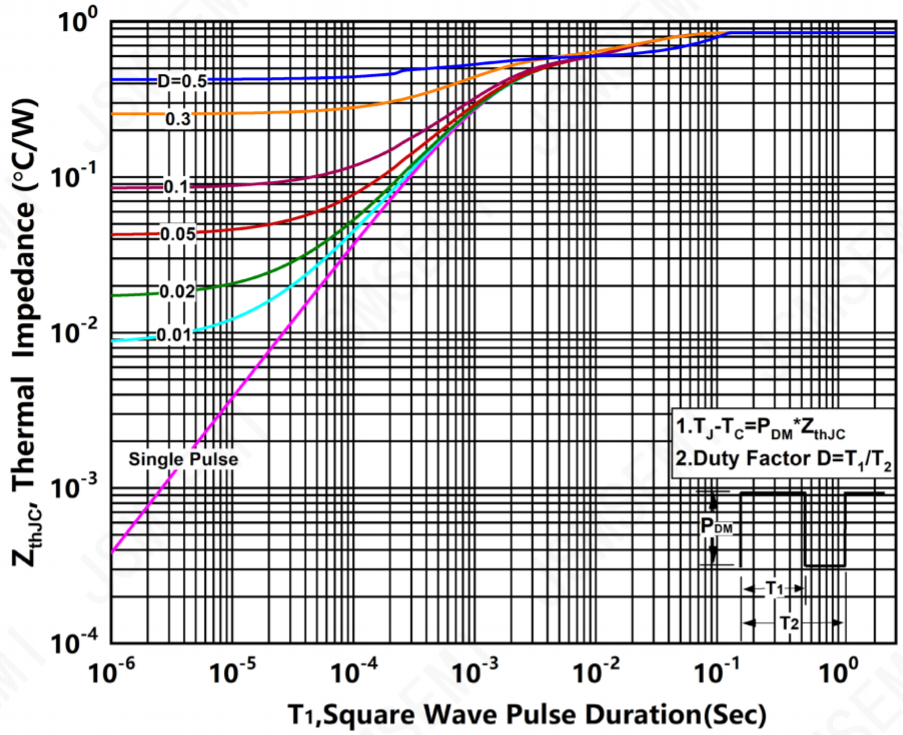
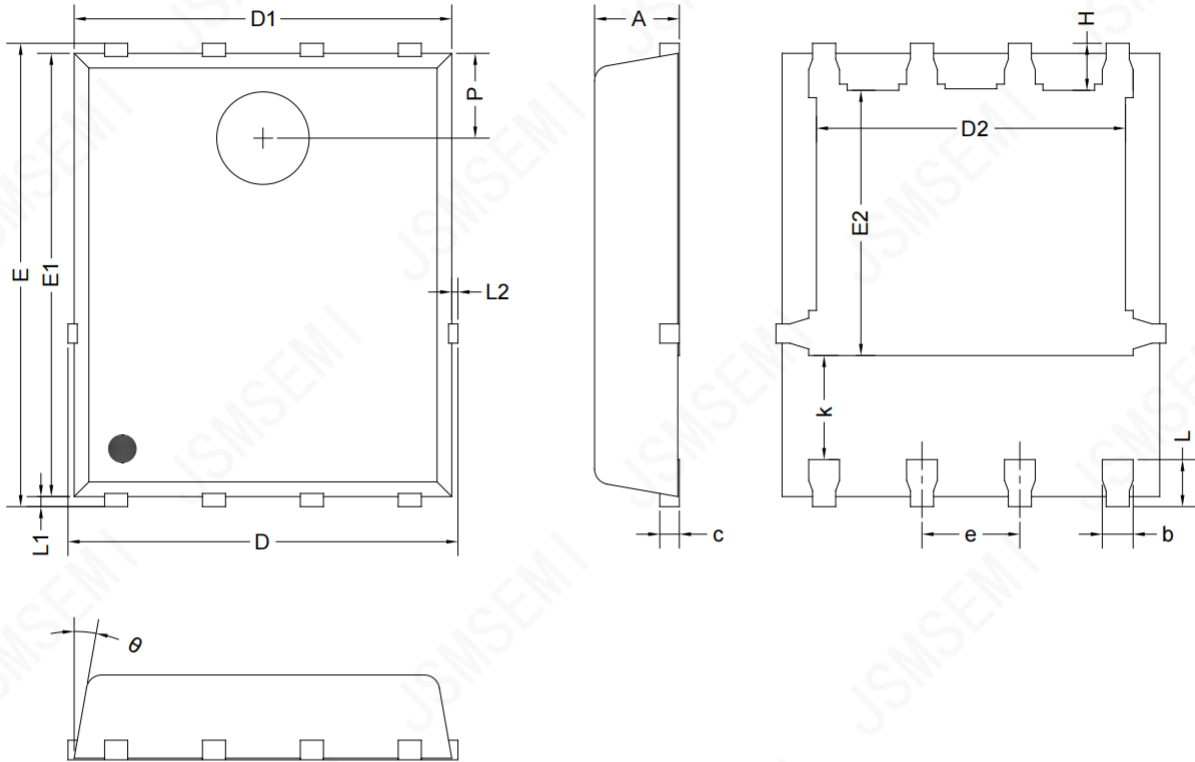

Figure.13 Transient Thermal Impedance (Junction - Case)

Package Information
DFN5060-8L

Symbol	Dimensions In Millimeters		
	MIN	NOM	MAX
A	1.000	1.100	1.200
b	0.350	0.400	0.450
c	0.210	0.250	0.340
D	4.800	-	5.100
D1	4.800	4.900	5.000
D2	3.910	4.010	4.110
E	5.900	6.000	6.100
E1	5.700	5.750	5.800
E2	3.340	3.440	3.540
e	1.270 BSC		
H	0.510	0.610	0.710
k	1.100	-	-
L	0.510	0.610	0.710
L1	0.060	0.130	0.200
L2	-	-	0.100
P	1.000	1.100	1.200
θ	8°	10°	12°

NOTE: This drawing is subject to change without notice.

Revision History

Rev.	Change	Date
V1.0	Initial version	6/27/2021

Important Notice

JSMSEMI Semiconductor (JSMSEMI) PRODUCTS ARE NEITHER DESIGNED NOR INTENDED FOR USE IN MILITARY AND/OR AEROSPACE, AUTOMOTIVE OR MEDICAL DEVICES OR SYSTEMS UNLESS THE SPECIFIC JSMSEMI PRODUCTS ARE SPECIFICALLY DESIGNATED BY JSMSEMI FOR SUCH USE. BUYERS ACKNOWLEDGE AND AGREE THAT ANY SUCH USE OF JSMSEMI PRODUCTS WHICH JSMSEMI HAS NOT DESIGNATED FOR USE IN MILITARY AND/OR AEROSPACE, AUTOMOTIVE OR MEDICAL DEVICES OR SYSTEMS IS SOLELY AT THE BUYER' S RISK.

JSMSEMI assumes no liability for application assistance or customer product design. Customers are responsible for their products and applications using JSMSEMI products.

Resale of JSMSEMI products or services with statements diferent from or beyond the parameters stated by JSMSEMI for that product or service voids all express and any implied warranties for the associated JSMSEMI product or s ervice. JSMSEMI is not responsible or liable for any such statements.

JSMSEMI All Rights Reserved. Information and data in this document are owned by JSMSEMI wholly and may not be edited, reproduced, or redistributed in any way without the express written consent from JSMSEMI.

Any and all information described or contained herein are subject to change without notice due to product/technology improvement, etc. When designing equipment, refer to the "Delivery Specification" for the JSMSEMI product that you intend to use.

For additional information please contact Kevin@jsmsemi.com or visit www.jsmsemi.com