

## OPA4343UA-HX SINGLE-SUPPLY, RAIL-TO-RAIL OPERATIONAL AMPLIFIERS MicroAmplifier™ Series

### DESCRIPTION

The OPA4343UA-HX series consists of rail-to-rail input/output CMOS operational amplifiers specifically engineered for cost-sensitive, space-constrained applications. Optimized for low-voltage, single-supply operation, these devices deliver both rail-to-rail input and output voltage swing alongside high-speed performance — making them particularly well suited for driving sampling analog-to-digital (A/D) converters. Their excellent dynamic characteristics and low distortion further position them as ideal solutions for general-purpose signal conditioning, audio applications, and current-to-voltage (I/V) conversion at the output stage of digital-to-analog (D/A) converters. Identical electrical specifications across the single-, dual-, and quad-channel variants enhance design flexibility and streamline component selection.

The OPA4343UA-HX operates from a single supply as low as 2.5 V. Its input common-mode voltage range extends 500 mV beyond both supply rails, while the output voltage swings to within 1 mV of the supply rails under a 100-k $\Omega$  load. Featuring outstanding dynamic response—including a 5.5-MHz unity-gain bandwidth and a 6-V/ $\mu$ s slew rate—the devices maintain a low quiescent current of only 850  $\mu$ A. Dual- and quad-channel versions incorporate fully independent circuitry to minimize crosstalk and eliminate inter-channel interaction.

The single-channel OPA4343UA-HX is available in compact surface-mount packages: SOP-14.

### FEATURES

- ★ RAIL-TO-RAIL INPUT/OUTPUT
- ★ MICRO SIZE PACKAGES
- ★ WIDE BANDWIDTH: 5.5MHz
- ★ HIGH SLEW RATE: 6V/ $\mu$ s
- ★ LOW THD+NOISE: 0.0007% (f = 1kHz)
- ★ LOW QUIESCENT CURRENT: 850  $\mu$ A/chan
- ★ SINGLE, DUAL, AND QUAD VERSIONS

### APPLICATIONS

- ★ DRIVING A/D CONVERTERS
- ★ PCMCIA CARDS
- ★ DATA ACQUISITION
- ★ AUDIO PROCESSING
- ★ COMMUNICATIONS
- ★ ACTIVE FILTERS
- ★ TEST EQUIPMENT

	Number of Channels	Package
OPA343NA-HX	Single Op Amp	SOT23-5
OPA343UA-HX	Single Op Amp	SOP-8
OPA2343EA-HX	Dual Op Amp	MSOP-8
OPA2343UA-HX	Dual Op Amp	SOP-8
OPA4343UA-HX	Quad Op Amp	SOP-14
OPA4343NA-HX	Quad Op Amp	TSSOP-14

## Pin diagram

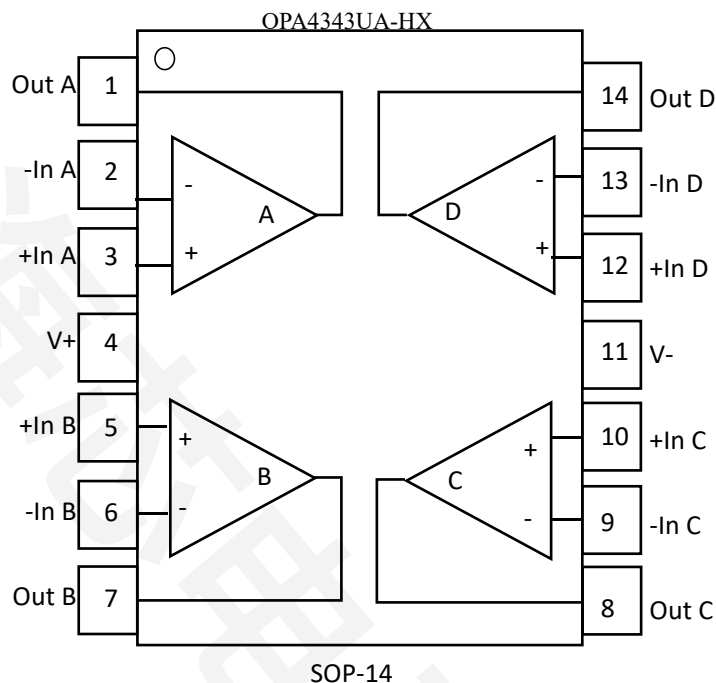

## ABSOLUTE MAXIMUM RATINGS<sup>(1)</sup>

Supply Voltage	7.5V	Signal
Input Terminals, Voltage <sup>(2)</sup>	(V-) -0.5V to (V+) +0.5V	
Current <sup>(2)</sup>	10mA	
Output Short-Circuit <sup>(3)</sup>	Continuous	
Operating Temperature	-55°C to +125°C	Storage
Temperature	-65°C to +150°C	Junction
Temperature	150°C	Lead
Temperature (soldering, 10s)	300°C	

NOTES: (1) Stresses above these ratings may cause permanent damage. Exposure to absolute maximum conditions for extended periods may de-grade device reliability. (2) Input terminals are diode-clamped to the power supply rails. Input signals that can swing more than 0.5V beyond the supply rails should be current-limited to 10mA or less. (3) Short-circuit to ground, one amplifier per package.

This integrated circuit can be damaged by ESD. Burr-Brown recommends that all integrated circuits be handled with appropriate precautions. Failure to observe proper handling and installation procedures can cause damage.

ESD damage can range from subtle performance degradation to complete device failure. Precision integrated circuits may be more susceptible to damage because very small parametric changes could cause the device not to meet its published specifications.

## PACKAGE/ORDERING INFORMATION

PRODUCT	PACKAGE	SPECIFIED TEMPERATURE RANGE	ORDERING NUMBER <sup>(1)</sup>	TRANSPORT MEDIA
Single				
OPA4343UA-HX	SOP-14 Surface-Mount	-40°C to +85°C	OPA4343UA-HX	Rails
"	"	"	OPA4343UA-HX/2K5	Tape and Reel

NOTE: (1) Models with a slash (/) are available only in Tape and Reel in the quantities indicated (e.g., /2K5 indicates 2500 devices per reel).

## SPECIFICATIONS: $V_S = 2.7V$ to $5.5V$

**Boldface** limits apply over the specified temperature range,  $T_A = -40^\circ C$  to  $+85^\circ C$ .  $V_S = 5V$ .

At  $T_A = +25^\circ C$ ,  $R_L = 10k\Omega$  connected to  $V_S/2$  and  $V_{OUT} = V_S/2$ , unless otherwise noted.

PARAMETER	CONDITION	OPA4343UA-HX			UNITS
		MIN	TYP(1)	MAX	
<b>OFFSET VOLTAGE</b>					
Input Offset Voltage	$V_{OS}$	$V_S = 5V$			mV
$V_S$ Temperature	$dV_{OS}/dT$				$\mu V/^\circ C$
vs Power Supply	PSRR	$V_S = 2.7V$ to $5.5V$ , $V_{CM} = 0V$			$\mu V/V$
<b>Over Temperature</b>		$V_S = 2.7V$ to $5.5V$ , $V_{CM} = 0V$			$\mu V/V$
Channel Separation, dc					$\mu V/V$
<b>INPUT BIAS CURRENT</b>					
Input Bias Current	$I_B$				pA
<b>Over Temperature</b>					pA
Input Offset Current	$I_{OS}$				pA
<b>NOISE</b>					
Input Voltage Noise, $f = 0.1$ to $50kHz$					$\mu V_{rms}$
Input Voltage Noise Density, $f = 1kHz$	$e_n$				$nV/\sqrt{Hz}$
Current Noise Density, $f=1kHz$	$i_n$				$fA/\sqrt{Hz}$
<b>INPUT VOLTAGE RANGE</b>					
Common-Mode Voltage Range	$V_{CM}$	$-0.3V < V_{CM} < (V+) - 1.8V$			V
Common-Mode Rejection Ratio	CMRR	74	92	$(V+) + 0.3$	dB
		60	75		dB
		54	70		dB
<b>INPUT IMPEDANCE</b>					
Differential					$\Omega \parallel pF$
Common-Mode					$\Omega \parallel pF$
<b>OPEN-LOOP GAIN</b>					
Open-Loop Voltage Gain	$A_{OL}$	$R_L = 100k\Omega$ , $5mV < V_O < (V+) - 5mV$			dB
<b>Over Temperature</b>		$R_L = 100k\Omega$ , $5mV < V_O < (V+) - 5mV$			dB
		$R_L = 10k\Omega$ , $50mV < V_O < (V+) - 50mV$			dB
<b>Over Temperature</b>		$R_L = 10k\Omega$ , $50mV < V_O < (V+) - 50mV$			dB
		$R_L = 2k\Omega$ , $200mV < V_O < (V+) - 200mV$			dB
<b>Over Temperature</b>		$R_L = 2k\Omega$ , $200mV < V_O < (V+) - 200mV$			dB
<b>FREQUENCY RESPONSE</b>					
Gain-Bandwidth Product	GBW	$G = 1$			MHz
Slew Rate	SR	$V_S = 5V$ , $G = 1$ , $C_L = 100pF$			$V/\mu s$
Settling Time, 0.1%		$V_S = 5V$ , 2V Step, $C_L = 100pF$			$\mu s$
0.01%		$V_S = 5V$ , 2V Step, $C_L = 100pF$			$\mu s$
Overload Recovery Time		$V_{IN} \cdot G = V_S$			$\mu s$
Total Harmonic Distortion + Noise	THD+N	$V_S = 5V$ , $V_O = 3Vp-p^{(2)}$ , $G = 1$ , $f = 1kHz$			%
<b>OUTPUT</b>					
Voltage Output Swing from Rail <sup>(3)</sup>		$R_L = 100k\Omega$ , $A_{OL} \geq 100dB$			mV
<b>Over Temperature</b>		$R_L = 100k\Omega$ , $A_{OL} \geq 100dB$			mV
		$R_L = 10k\Omega$ , $A_{OL} \geq 100dB$			mV
<b>Over Temperature</b>		$R_L = 10k\Omega$ , $A_{OL} \geq 100dB$			mV
		$R_L = 2k\Omega$ , $A_{OL} \geq 92dB$			mV
<b>Over Temperature</b>		$R_L = 2k\Omega$ , $A_{OL} \geq 92dB$			mV
Short-Circuit Current	$I_{SC}$				mA
Capacitive Load Drive	$C_{LOAD}$				
See Typical Curve					
<b>POWER SUPPLY</b>					
Specified Voltage Range	$V_S$	2.7			V
Operating Voltage Range		2.5 to 5.5			V
Quiescent Current (per amplifier)	$I_Q$	$I_O = 0$ , $V_S = +5V$			mA
<b>Over Temperature</b>		$I_O = 0$ , $V_S = +5V$			mA
<b>TEMPERATURE RANGE</b>					
Specified Range		-40			$^\circ C$
Operating Range		-55			$^\circ C$
Storage Range		-65			$^\circ C$
Thermal Resistance	$\theta_{JA}$				
SOP-14 Surface Mount		100			$^\circ C/W$

NOTES: (1)  $V_S = +5V$ . (2)  $V_{OUT} = 0.25V$  to  $3.25V$ . (3) Output voltage swings are measured between the output and power supply rails.

## TYPICAL PERFORMANCE CURVES

At  $T_A = +25^\circ\text{C}$ ,  $V_S = +5\text{V}$ , and  $R_L = 10\text{k}\Omega$  connected to  $V_S/2$ , unless otherwise noted.

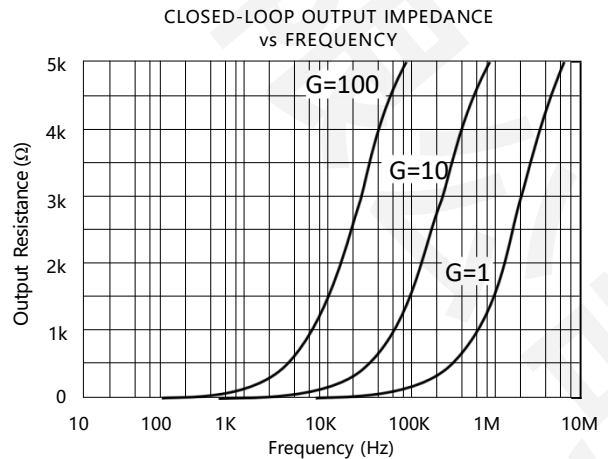
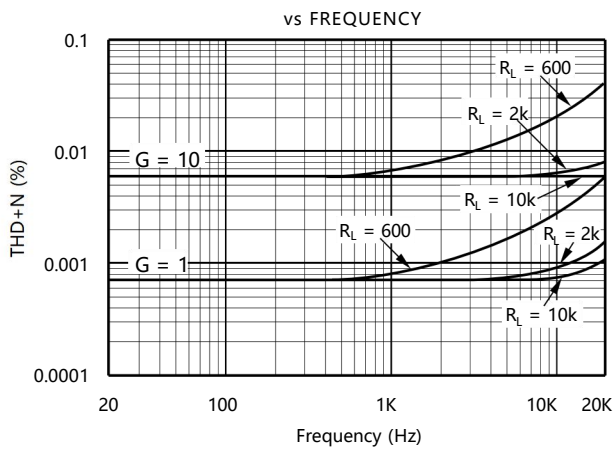
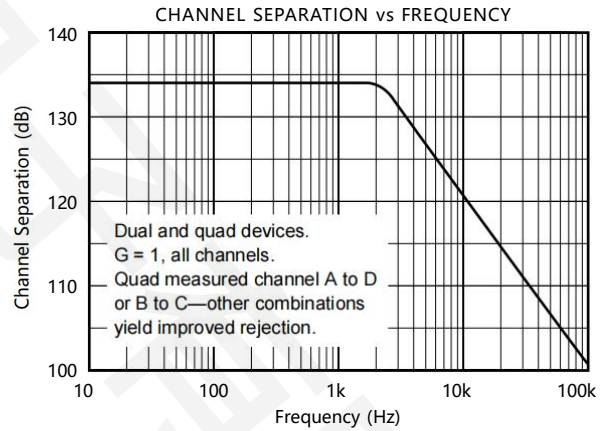
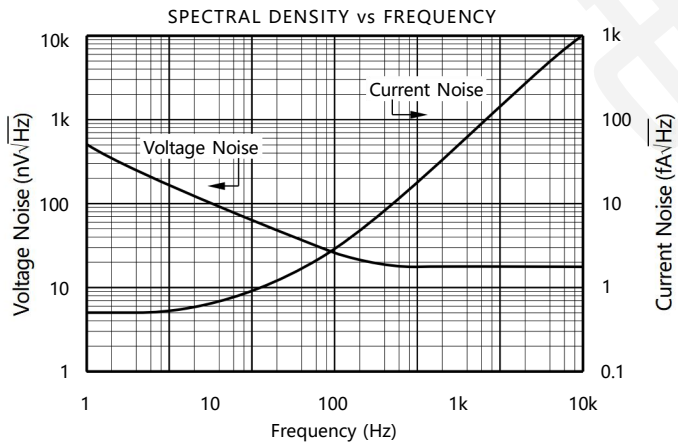
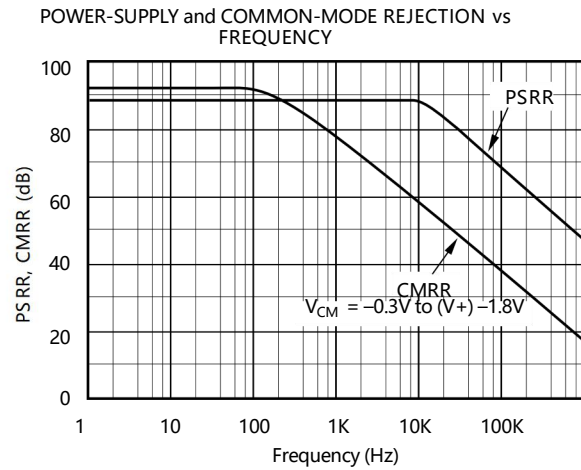
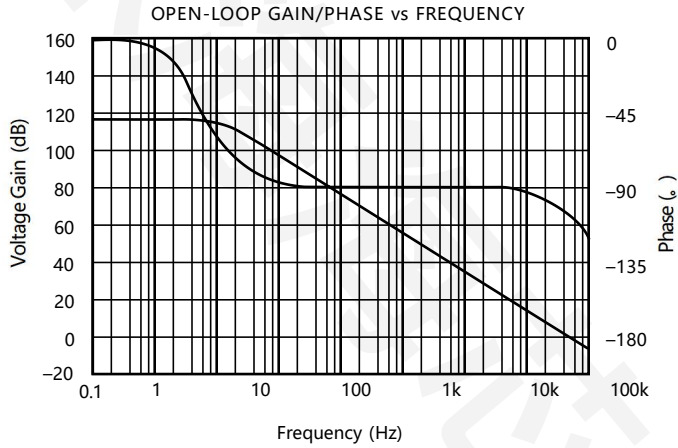

## TYPICAL PERFORMANCE CURVES (Cont.)

At  $T_A = +25^\circ\text{C}$ ,  $V_S = +5\text{V}$ , and  $R_L = 10\text{k}\Omega$  connected to  $V_S/2$ , unless otherwise noted.

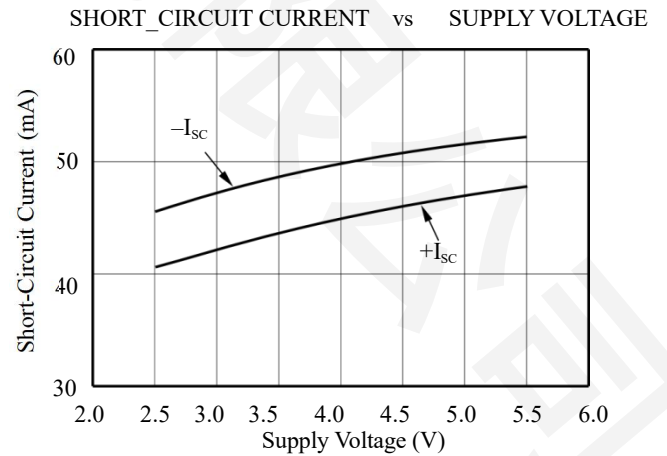
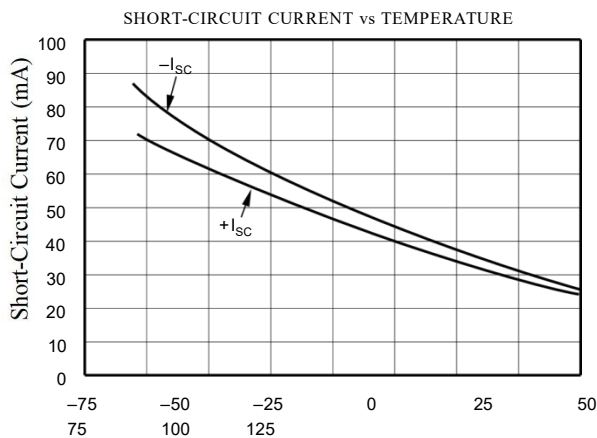
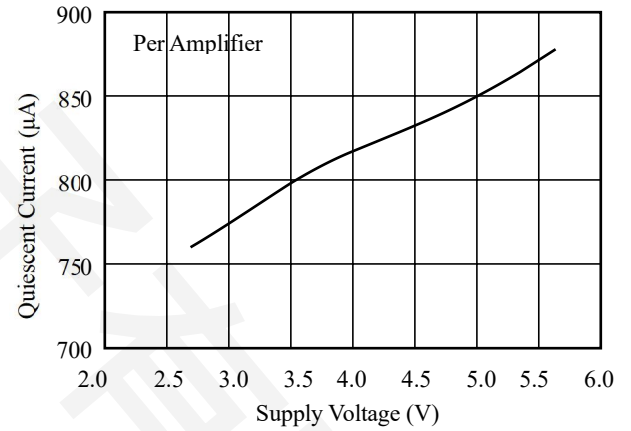
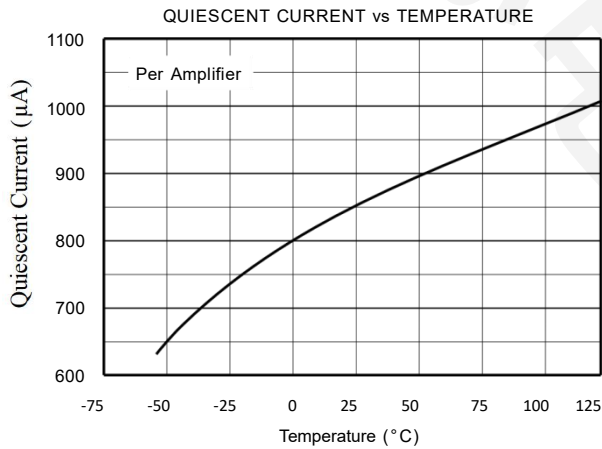
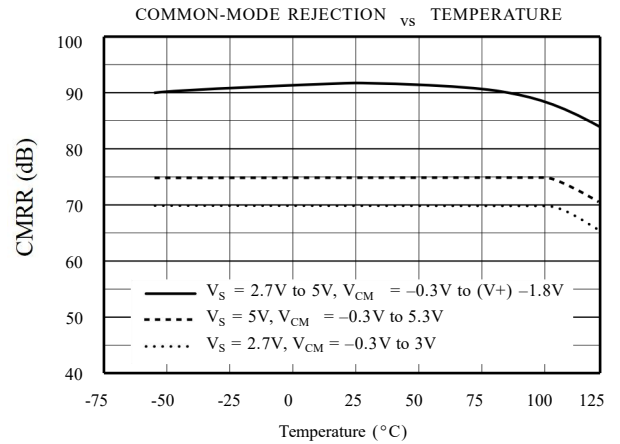
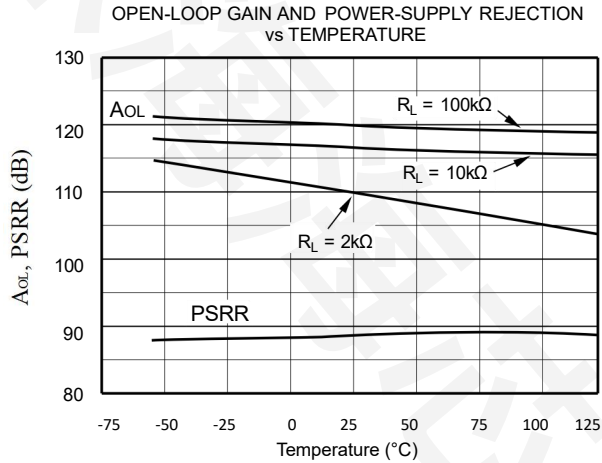

## TYPICAL PERFORMANCE CURVES (Cont.)

At  $T_A = +25^\circ\text{C}$ ,  $V_S = +5\text{V}$ , and  $R_L = 10\text{k}\Omega$  connected to  $V_S/2$ , unless otherwise noted.

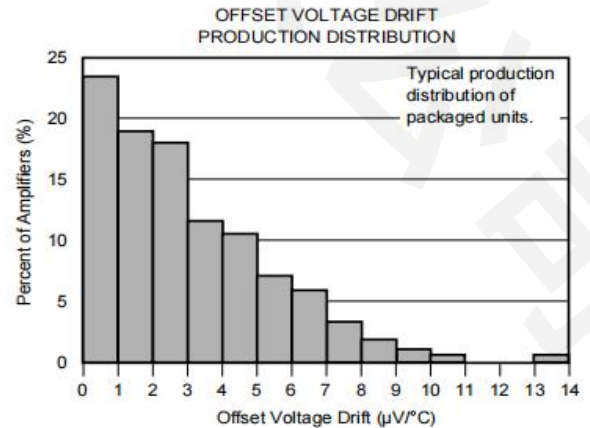
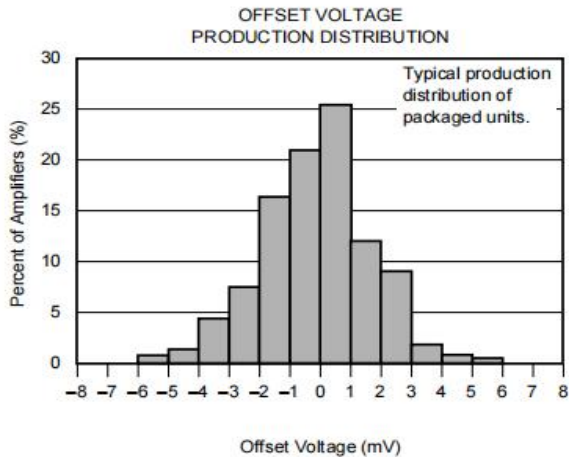
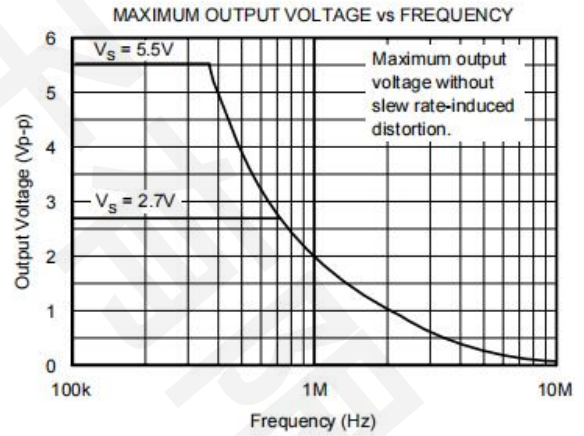
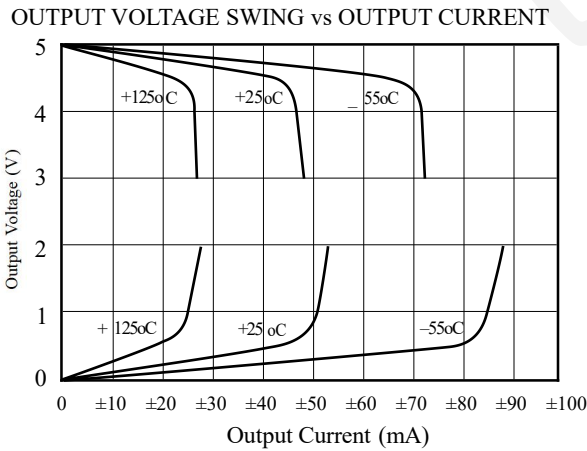
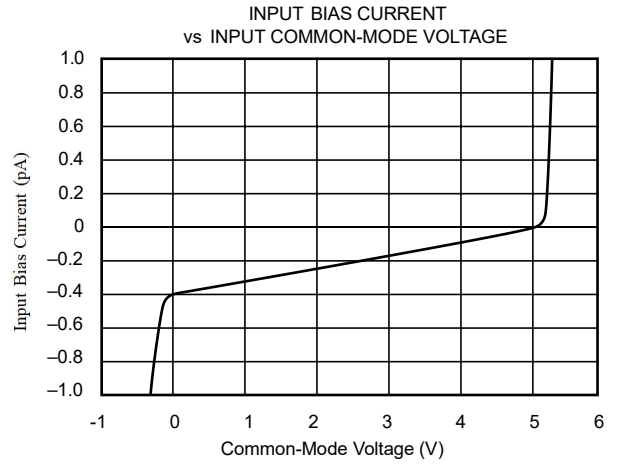
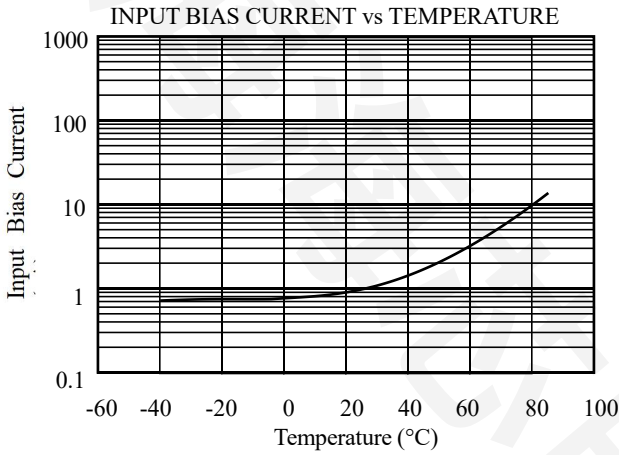

## TYPICAL PERFORMANCE CURVES (Cont.)

At  $T_A = +25^\circ\text{C}$ ,  $V_S = +5\text{V}$ , and  $R_L = 10\text{k}\Omega$  connected to  $V_S/2$ , unless otherwise noted.

SMALL-SIGNAL STEP RESPONSE

$C_L = 100\text{pF}$

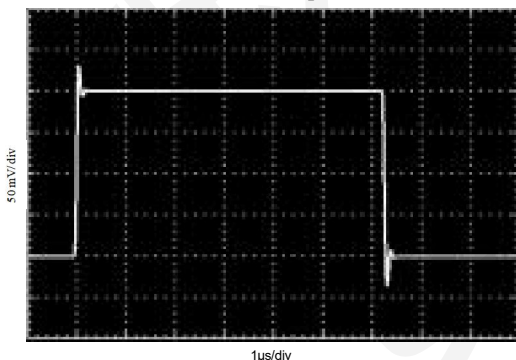

$C_L = 100\text{pF}$

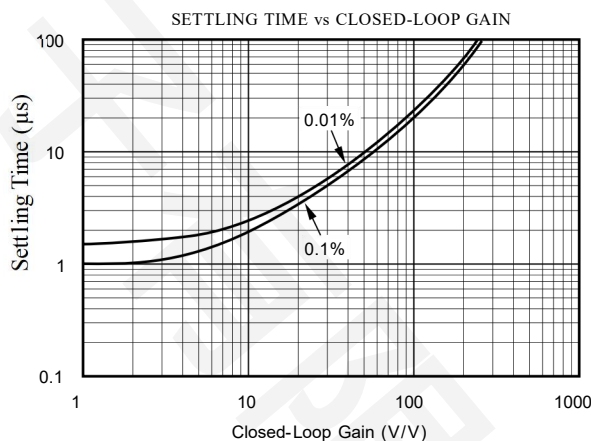
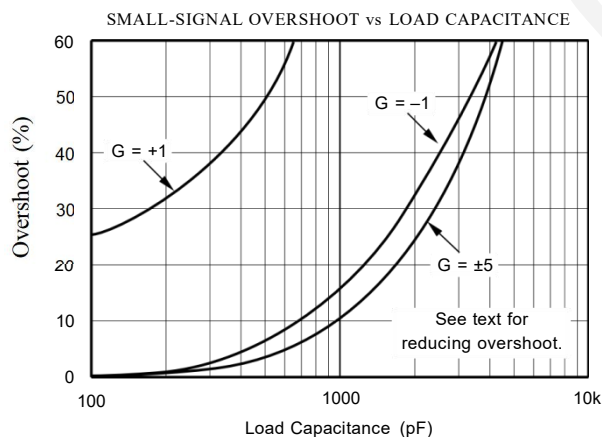
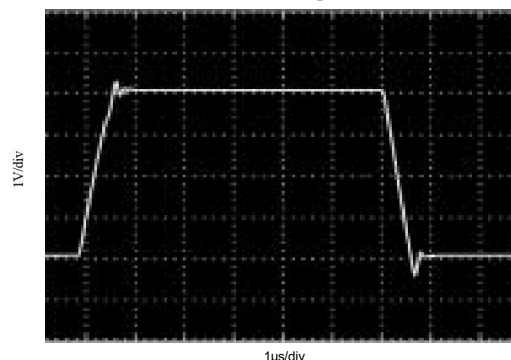

## APPLICATIONS INFORMATION

OPA4343UA-HX series op amps are fabricated on a state-of-the-art 0.6 micron CMOS process. They are unity-gain stable and suitable for a wide range of general-purpose applications. Rail-to-rail input/output make them ideal for driving sampling A/D converters. In addition, excellent ac performance makes them well-suited for audio applications. The class AB output stage is capable of driving  $600\Omega$  loads connected to any point between  $V_+$  and ground.

Rail-to-rail input and output swing significantly increases dynamic range, especially in low-supply applications. Figure 1 shows the input and output waveforms for the OPA4343UA-HX in unity-gain configuration. Operation is from a single  $+5\text{V}$  supply with a  $10\text{k}\Omega$  load connected to  $V_S/2$ . The input is a  $5\text{Vp-p}$  sinusoid. Output voltage is approximately  $4.98\text{Vp-p}$ .

Power-supply pins should be bypassed with  $0.01\mu\text{F}$  ceramic capacitors.

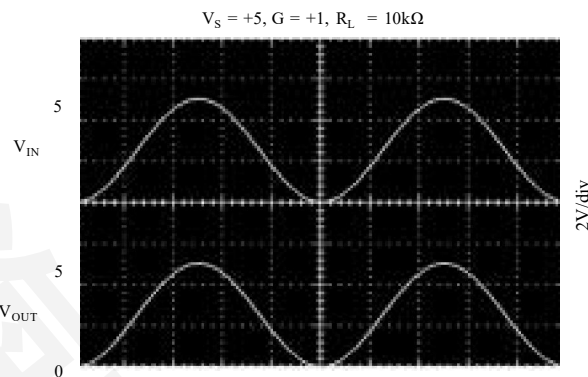

Figure 1. Rail-to-Rail Input and Output.

### OPERATING VOLTAGE

OPA4343UA-HX series op amps are fully specified from +2.7V to +5V. However, supply voltage may range from +2.5V to +5.5V. Parameters are guaranteed over the specified supply range—a unique feature of the OPA4343UA-HX series. In addition, many specifications apply from  $-40^{\circ}\text{C}$  to  $+85^{\circ}\text{C}$ . Most behavior remains virtually unchanged throughout the full operating voltage range. Parameters which vary significantly with operating voltages or temperature are shown in the Typical Performance Curves.

### RAIL-TO-RAIL INPUT

The input common-mode voltage range of the OPA4343UA-HX series extends 500mV beyond the supply rails. This is achieved with a complementary input stage—an N-channel input differential pair in parallel with a P-channel differential pair, as shown in Figure 2. The N-channel pair is active for input voltages close to the positive rail, typically  $(V^+) - 1.3\text{V}$  to 500mV above the positive supply. The P-channel pair is on for inputs from 500mV below the negative supply to approximately  $(V^+) - 1.3\text{V}$ .

There is a small transition region, typically  $(V^+) - 1.5\text{V}$  to  $(V^+) - 1.1\text{V}$ , in which both input pairs are on. This 400mV transition region can vary  $\pm 300\text{mV}$  with process variation. Thus, the transition region (both stages on) can range from  $(V^+) - 1.8\text{V}$  to  $(V^+) - 1.4\text{V}$  on the low end, up to  $(V^+) - 1.2\text{V}$  to  $(V^+) - 0.8\text{V}$  on the high end. Within the 400mV transition region PSRR, CMRR, offset voltage, offset drift, and THD may be degraded compared to operation outside this region.

A double-folded cascode adds the signal from the two input pairs and presents a differential signal to the class AB output stage. Normally, input bias current is approximately 200fA, however, input voltages exceeding the power supplies by

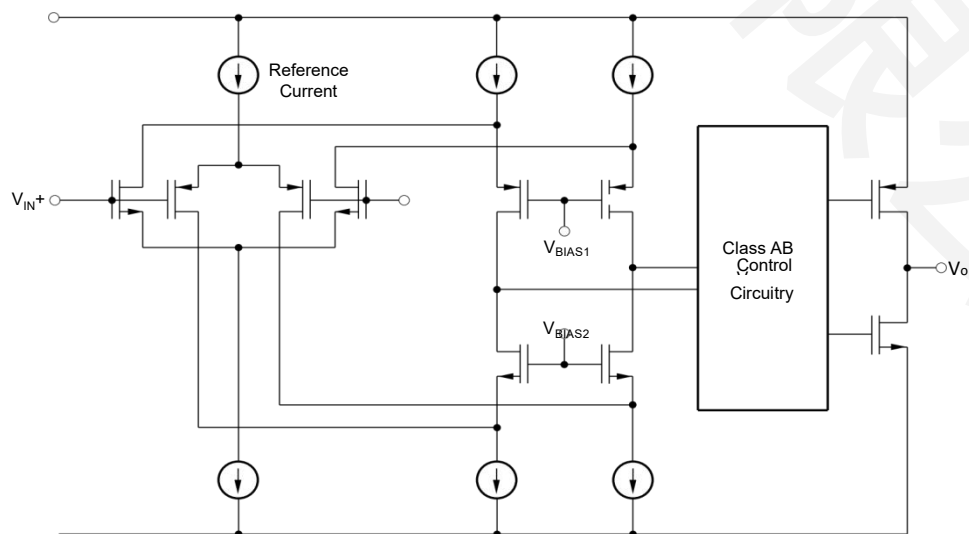

Figure 2. Simplified Schematic.

more than 500mV can cause excessive current to flow in or out of the input pins. Momentary voltages greater than 500mV beyond the power supply can be tolerated if the current on the input pins is limited to 10mA. This is easily accomplished with an input resistor, as shown in Figure 3. Many input signals are inherently current-limited to less than 10mA, therefore, a limiting resistor is not required.

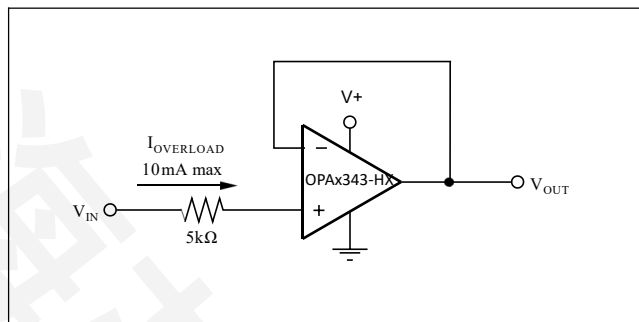

Figure 3. Input Current Protection for Voltages Exceeding the Supply Voltage.

### RAIL-TO-RAIL OUTPUT

A class AB output stage with common-source transistors is used to achieve rail-to-rail output. For light resistive loads ( $>50k\Omega$ ), the output voltage is typically a few millivolts from the supply rails. With moderate resistive loads ( $2k\Omega$  to  $50k\Omega$ ), the output can swing to within a few tens of millivolts from the supply rails and maintain high open-loop gain. See the typical performance curve “Output Voltage Swing vs Output Current.”

### CAPACITIVE LOAD AND STABILITY

OPA4343UA-HX series op amps can drive a wide range of capacitive loads. However, all op amps under certain conditions may become unstable. Op amp configuration, gain, and load value are just a few of the factors to consider when determining stability. An op amp in unity gain configuration is the most susceptible to the effects of capacitive load. The capacitive load reacts with the op amp’s output resistance, along with any additional load resistance, to create a pole in the small-signal response which degrades the phase margin. In unity gain, OPA4343UA-HX series op amps perform well, with a pure capacitive load up to approximately 1000pF. Increasing gain enhances the amplifier’s ability to drive more capacitance. See the typical performance curve “Small-Signal Overshoot vs Capacitive Load.”

One method of improving capacitive load drive in the unity gain configuration is to insert a  $10\Omega$  to  $20\Omega$  resistor in series with the output, as shown in Figure 4. This significantly reduces ringing with large capacitive loads. However, if there is a resistive load in parallel with the capacitive load,  $R_S$  creates a voltage divider. This introduces a dc error at the output and slightly reduces output swing. This error may be insignificant. For instance, with  $R_L = 10k\Omega$  and  $R_S = 20\Omega$ , there is only about a 0.2% error at the output.

### DRIVING A/D CONVERTERS

OPA4343UA-HX series op amps are optimized for driving medium speed (up to 100kHz) sampling A/D converters. However, they also offer excellent performance for higher-speed converters. The OPA4343UA-HX series provides an effective means of buffering the A/D’s input capacitance and resulting charge injection while providing signal gain. For applications requiring high accuracy, the OPA340-HX series is recommended.

Figures 5 and 6 show the OPA4343UA-HX driving an ADS7816-HX. The ADS7816-HX is a 12-bit, micro-power sampling converter in the tiny MSOP-8 package. When used with the miniature package options of the OPA4343UA-HX series, the combination is ideal for space-limited and low-power applications. For further information consult the ADS7816-HX data sheet.

With the OPA4343UA-HX in a noninverting configuration, an RC network at the amplifier’s output can be used to filter high frequency noise in the signal (see Figure 5). In the inverting configuration, filtering may be accomplished with a capacitor across the feedback resistor (see Figure 6).

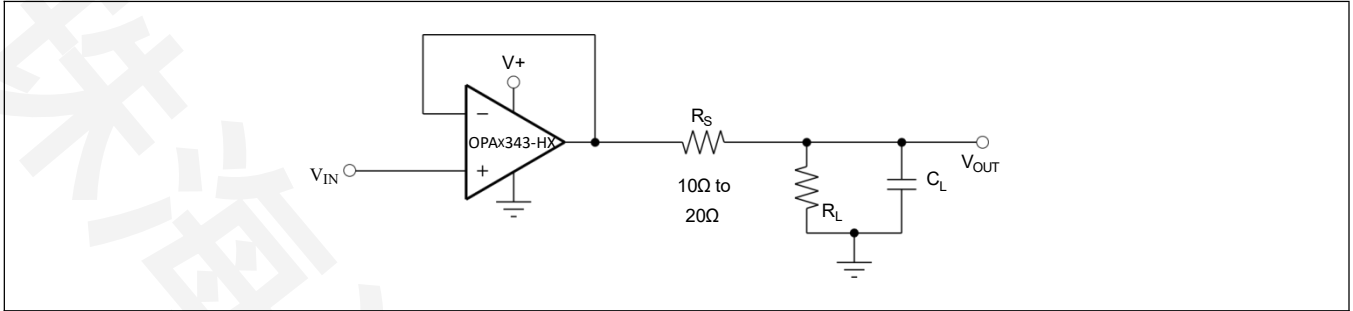

Figure 4. Series Resistor in Unity-Gain Configuration Improves Capacitive Load Drive.

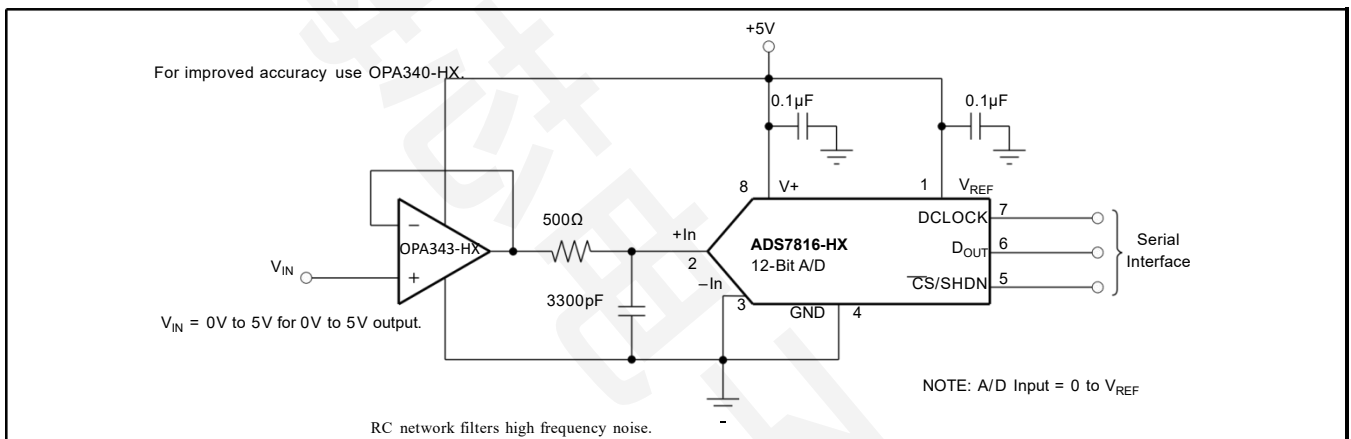

Figure 5. OPA4343UA-HX in Noninverting Configuration Driving ADS7816-HX.

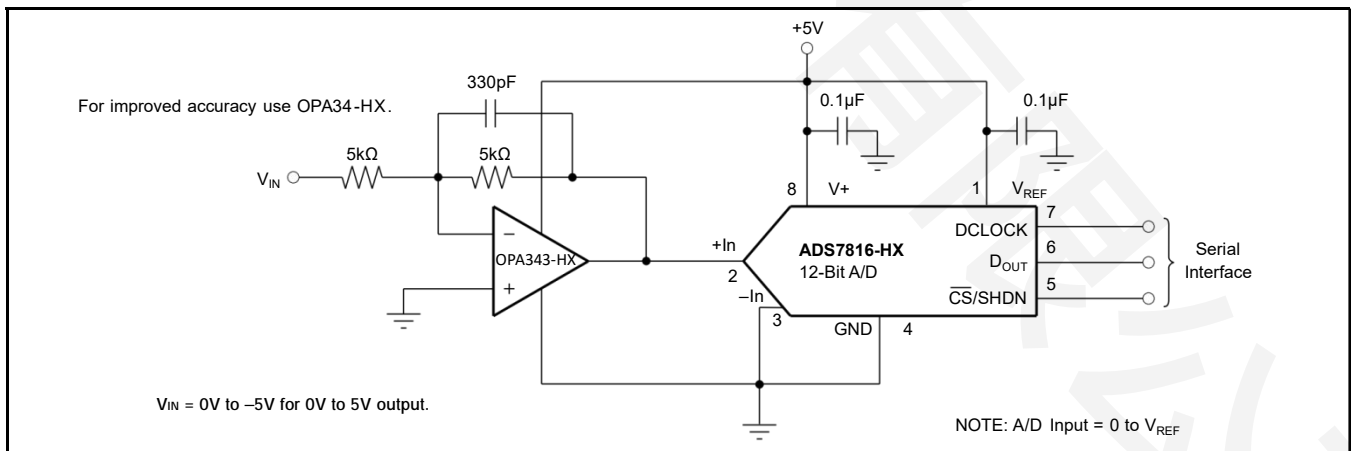

Figure 6. OPA4343UA-HX in Inverting Configuration Driving ADS7816-HX.

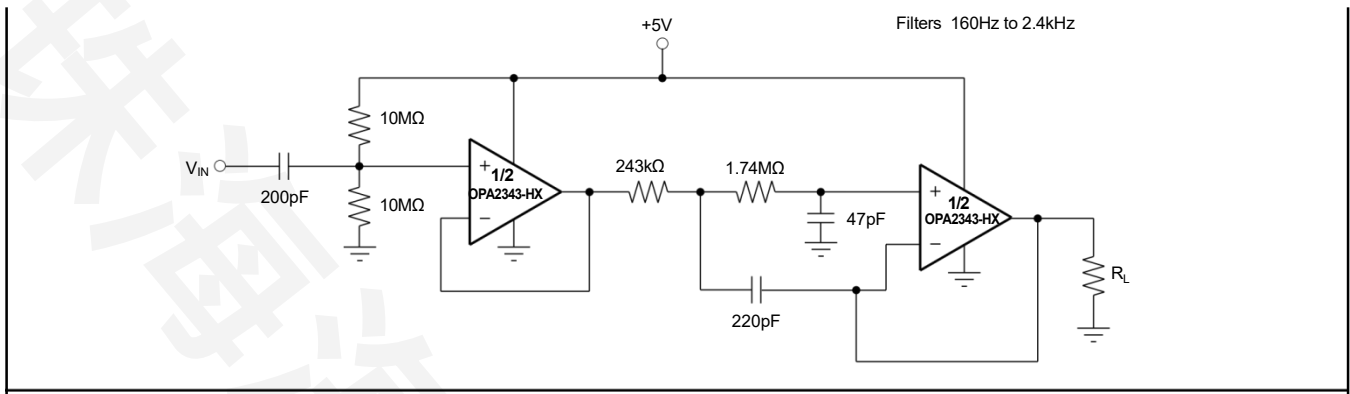

Figure 7. Speech Bandpass Filter.

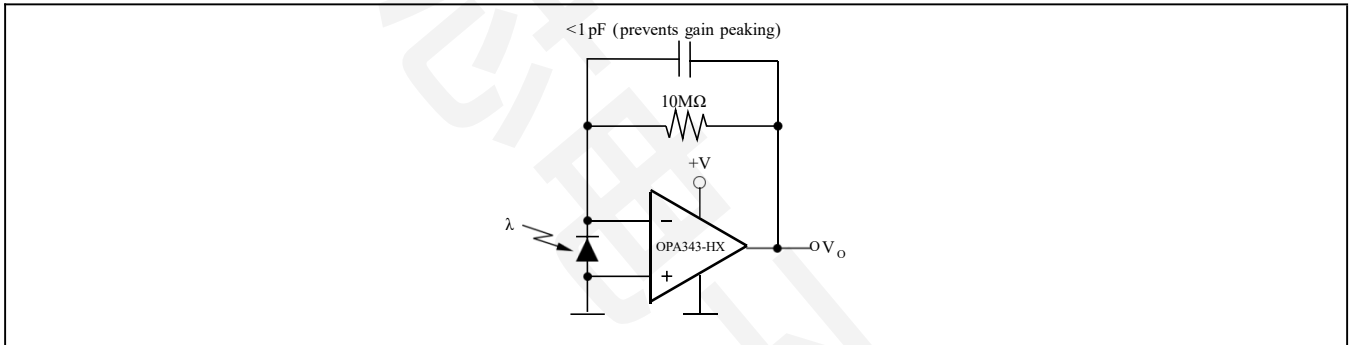
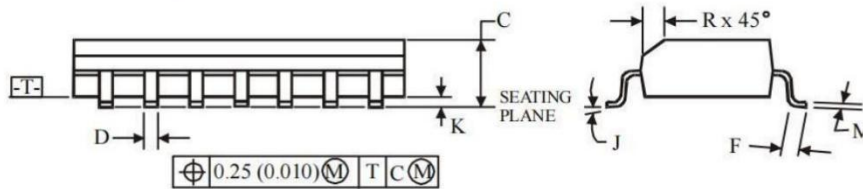
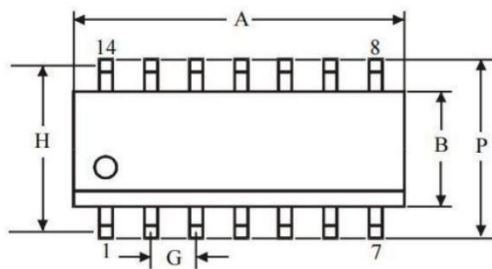

Figure 8. Transimpedance Amplifier.

## Package Information

### SOP-14



Symbol	Dimension, mm	
	MIN	MAX
A	8.55	8.75
B	3.8	4
C	1.35	1.75
D	0.33	0.51
F	0.4	1.27
G	1.27	
H	5.27	
J	0°	8°
K	0.1	0.25
M	0.19	0.25
P	5.8	6.2
R	0.25	0.5

#### NOTES:

- Dimensions A and B do not include mold flash or protrusion.
- Maximum mold flash or protrusion 0.15 mm (0.006) per side for A; for B - 0.25 mm (0.010) per side.