

MSKSEMI 美森科

SEMICONDUCTOR



ESD



TVS



TSS



MOV



GDT



PLED

MSY8121BABC

Product specification

GENERAL DESCRIPTION

The MSY8121BABC is a fully integrated, high-efficiency 2.0A synchronous rectified step-down converter.

The MSY8121BABC operates at high efficiency over a wide output current load range.

This device offers two operation modes, PWM control and PFM Mode switching control which allows a high efficiency over the wider range of the load.

The MSY8121BABC requires a minimum number of readily available standard external components and is available in a 6-pin SOT23-6 ROHS compliant package.

FEATURES

- High Efficiency: Up to 95%@5V
- 600kHz Frequency Operation
- 2.0A Output Current
- No Schottky Diode Required
- 3.5V to 18V Input Voltage Range
- 0.8V Reference
- Slope Compensated Current Mode Control for Excellent Line and Load Transient Response
- Integrated internal compensation Stable with Low ESR Ceramic Output Capacitors
- Over Current Protection with Hiccup-Mode
- Input overvoltage protection (OVP)
- Thermal Shutdown
- Inrush Current Limit and Soft Start
- Available in SOT23-6 Package

APPLICATIONS

- Distributed Power Systems
- Digital Set Top Boxes
- Flat Panel Television and Monitors
- Notebook computer
- Wireless and DSL Modems

Reference News

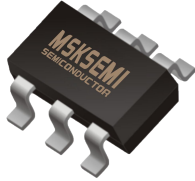
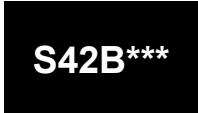
| Type No | SOT-23-6 | MARKING |
|-------------|---|---|
| MSY8121BABC |  |  |

Pin Assignments

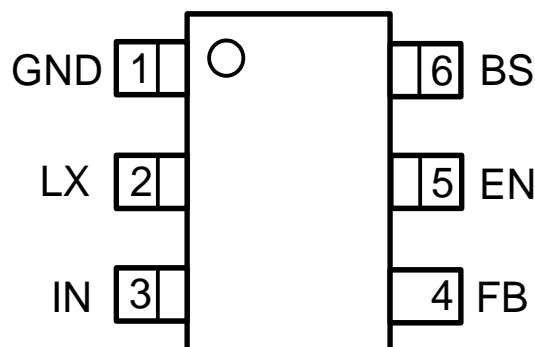

PIN FUNCTIONS

| Pin | Name | Function |
|-----|------|---|
| 1 | GND | Ground Pin |
| 2 | LX | Switching Pin |
| 3 | IN | Power supply Pin |
| 4 | FB | Output Voltage feedback input. Connect FB to the center point of the external resistor divider. |
| 5 | EN | Drive this pin to a logic-high to enable the IC. Drive to a logic-low to disable the IC and enter micro-power shutdown mode. Don't floating this pin. |
| 6 | BS | Bootstrap. A capacitor connected between LX and BST pins is required to form a floating supply across the high-side switch driver. |

TYPICAL APPLICATION

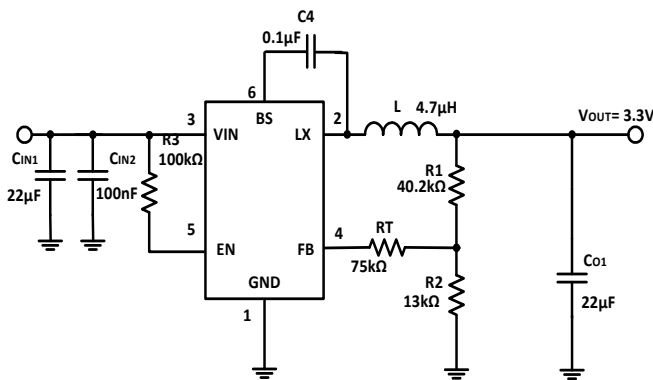
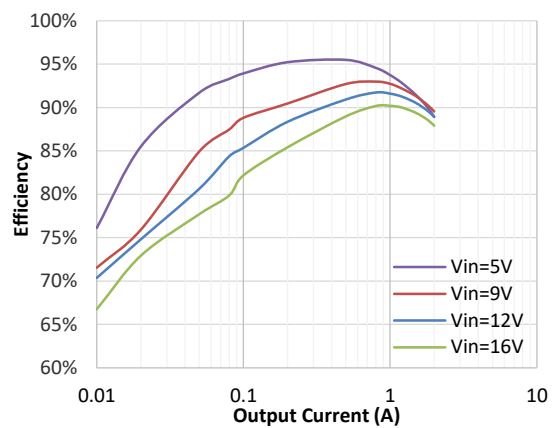

Figure 1. Basic Application Circuit

Efficiency

$V_{OUT}=3.3V, I_{OUT}=0.01A \text{ to } 2A, T_A=25^\circ C$



ABSOLUTE MAXIMUM RATINGS (Note 1)

| Parameter | Min | Max | Unit |
|----------------------------------|------|------|------|
| Input Supply Voltage, EN | -0.3 | 20 | V |
| LX Voltages | -0.3 | 20 | V |
| FB Voltage | -0.3 | 6 | V |
| BS Voltage | -0.6 | 25 | V |
| Storage Temperature Range | -65 | 150 | °C |
| Junction Temperature (Note 2) | | 160 | °C |
| Power Dissipation | | 1000 | mW |
| Lead Temperature (Soldering,10s) | | 260 | °C |

ESD RATING

| Items | Description | Value | Unit |
|------------------|-------------------------------|-------|------|
| V _{ESD} | Human Body Model for all pins | ±2000 | V |

JEDEC specification JS-001

RECOMMENDED OPERATING CONDITIONS

| Items | Description | Min | Max | Unit |
|----------------|--------------------------------|-----|-----|------|
| Voltage Range | IN Voltage | 3.5 | 18 | V |
| T _J | Operating Junction Temperature | -40 | 125 | °C |

THERMAL RESISITANCE (Note 3)

| Items | Description | Value | Unit |
|-----------------|--|-------|------|
| θ _{JA} | Junction-to-ambient thermal resistance | 130 | °C/W |

ELECTRICAL CHARACTERISTICS
(V_{IN}=12V, V_{OUT}=5V, T_A = 25°C, unless otherwise noted.)

| Parameter | Conditions | Min | Typ | Max | Unit |
|---|---|-------|-----|-------|------|
| Input Voltage Range | | 3.5 | | 18 | V |
| OVP Threshold | | | 19 | | V |
| UVLO Threshold | | 3.0 | | | V |
| Supply Current in Operation | V _{EN} =2.0V, No Load | | 400 | 600 | μA |
| Supply Current in Shutdown | V _{EN} =0 | | 2 | | μA |
| Regulated Feedback Voltage | T _A = 25°C, 3.5V ≤ V _{IN} ≤ 18V | 0.784 | 0.8 | 0.816 | V |
| High-Side Switch On-Resistance | | | 120 | | mΩ |
| Low-Side Switch On-Resistance | | | 70 | | mΩ |
| High-Side Switch Leakage Current | V _{EN} =0V, V _{LX} =0V | | 0 | 10 | μA |
| Upper Switch Current Limit | Minimum Duty Cycle | | 3.0 | | A |
| Oscillation Frequency | V _{FB} =0.8V | | 600 | | kHz |
| Maximum Duty Cycle | V _{FB} =0.8V | | 95 | | % |
| EN High-Level Input Voltage | | 1.50 | | | V |
| EN Low-Level Input Voltage | | | | 0.30 | V |
| Soft Start time | | | 800 | | μs |
| Minimum On-Time | | | 100 | | ns |
| Thermal Shutdown Threshold <small>(Note 4)</small> | | | 160 | | °C |
| Thermal Shutdown Hysteresis <small>(Note 4)</small> | | | 30 | | °C |

Note 1: Absolute Maximum Ratings are those values beyond which the life of a device may be impaired.

Note 2: T_J is calculated from the ambient temperature T_A and power dissipation P_D according to the following formula: T_J = T_A + P_D × θ_{JA}. The maximum allowable continuous power dissipation at any ambient temperature is calculated by P_{D(MAX)} = (T_{J(MAX)} - T_A) / θ_{JA}.

Note 3: Measured on JESD51-7, 4-layer PCB.

Note 4: Thermal shutdown threshold and hysteresis are guaranteed by design.

OPERATION

Internal Regulator

The MSY8121BABC is a current mode step down DC/DC converter that provides excellent transient response with no extra external compensation components. This device contains an internal, low resistance, high voltage power MOSFET, and operates at a high 600kHz operating frequency to ensure a compact, high efficiency design with excellent AC and DC performance.

Error Amplifier

The error amplifier compares the FB pin voltage with the internal FB reference (V_{FB}) and outputs a current proportional to the difference between the two. This output current is then used to charge or discharge the internal compensation network to form the COMP voltage, which is used to control the power MOSFET current. The optimized internal compensation network minimizes the external component counts and simplifies the control loop design.

Internal Soft-Start

The soft-start is implemented to prevent the converter output voltage from overshooting during startup. When the chip starts, the internal circuitry generates a soft-start voltage (SS) ramping up from 0V to 0.8V. When it is lower than the internal reference (V_{REF}), SS overrides REF so the error amplifier uses SS as the reference. When SS is higher than REF, REF regains control. The SS time is internally fixed to 800 μ s.

Over-Current-Protection and Hiccup

The MSY8121BABC has cycle-by-cycle over current limit when the inductor current peak value exceeds the set current limit threshold. Meanwhile, output voltage starts to drop until FB is below the Under-Voltage (UV) threshold, typically 55% below the reference. Once a UV is triggered, the MSY8121BABC enters hiccup mode to periodically restart the part. This protection mode is especially useful when the output is dead-short to ground. The average short circuit current is greatly reduced to alleviate the thermal issue and to protect the regulator. The MSY8121BABC exits the hiccup mode once the over current condition is removed.

Startup and Shutdown

If both VIN and EN are higher than their appropriate thresholds, the chip starts. The reference block starts first, generating stable reference voltage and currents, and then the internal regulator is enabled. The regulator provides stable supply for the remaining circuitries. Three events can shut down the chip: EN low, VIN low and thermal shutdown. In the shutdown procedure, the signaling path is first blocked to avoid any fault triggering. The COMP voltage and the internal supply rail are then pulled down. The floating driver is not subject to this shutdown command.

FUNCTIONAL BLOCK DIAGRAM

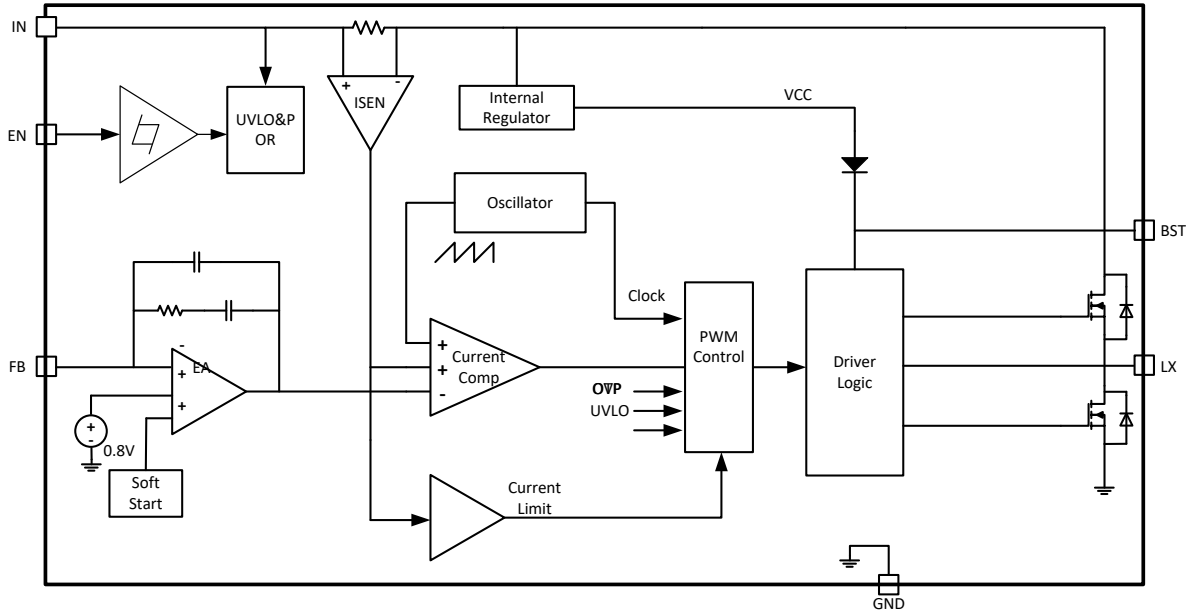

Figure 2. MSY8121BABC Block Diagram

TYPICAL PERFORMANCE CHARACTERISTICS

Test condition: $V_{IN}=12V$, $V_{OUT}=3.3V$, $L=4.7\mu H$, $T_A=+25^\circ C$, unless other noted.

Efficiency at $V_{OUT} = 3.3V$

$V_{OUT}=3.3V$, $L=4.7\mu H$, $DCR=30m\Omega$

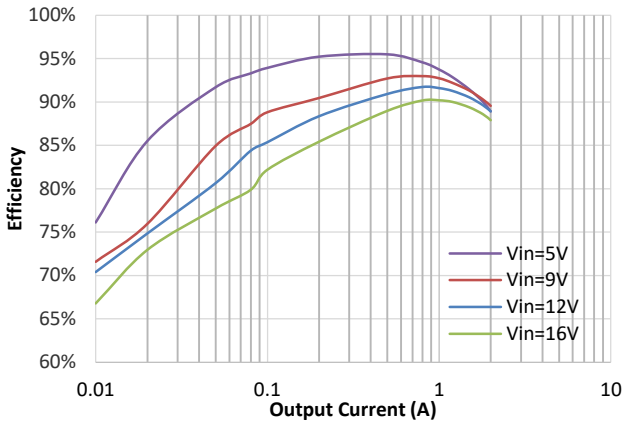

Efficiency at $V_{OUT} = 5V$

$V_{OUT}=5V$, $L=4.7\mu H$, $DCR=30m\Omega$

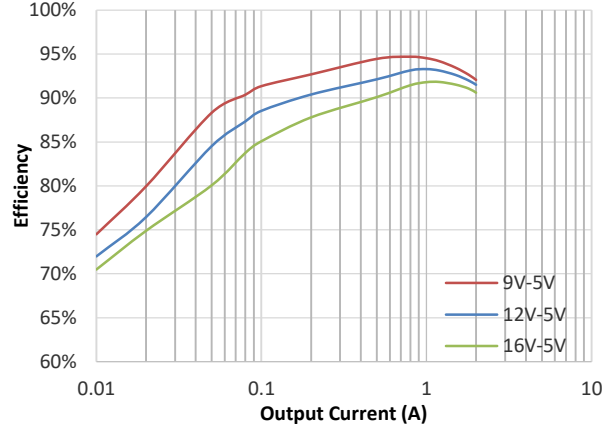

Line Regulation at $V_{OUT}=3.3V$

$V_{OUT}=3.3V$, $T_A=25^\circ C$

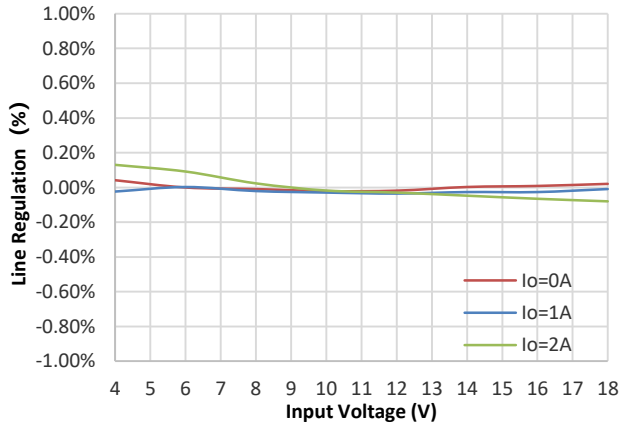

Load Regulation at $V_{IN} = 12V$

$V_{IN}=12V$, $T_A=25^\circ C$

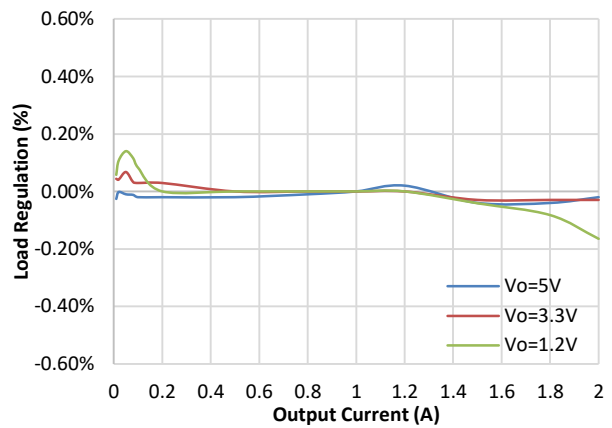

Steady State Operation

$V_{IN}=12V$, $V_{OUT}=3.3V$, No Load

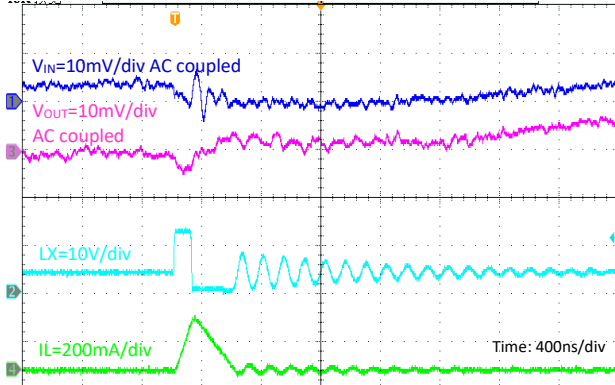

Steady State Operation

$V_{IN}=12V$, $V_{OUT}=3.3V$, $I_o=2A$

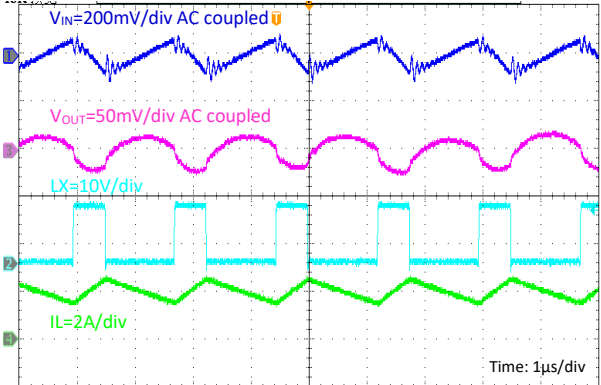

TYPICAL PERFORMANCE CHARACTERISTICS (continued)

Load Transient

$V_{IN} = 12V, V_{OUT} = 3.3V, I_o = 0.5A \text{ to } 1.5A$

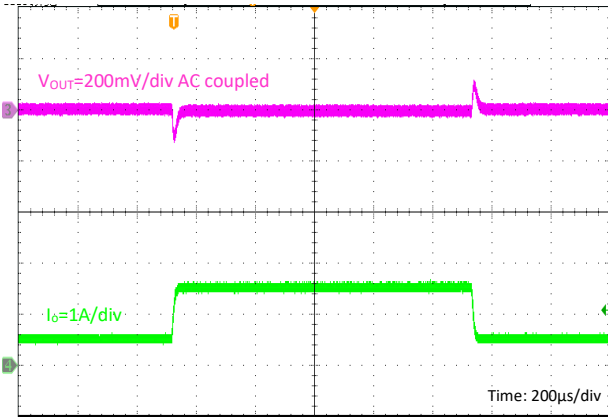

Load Transient

$V_{IN} = 12V, V_{OUT} = 3.3V, I_o = 1.0A \text{ to } 2A$

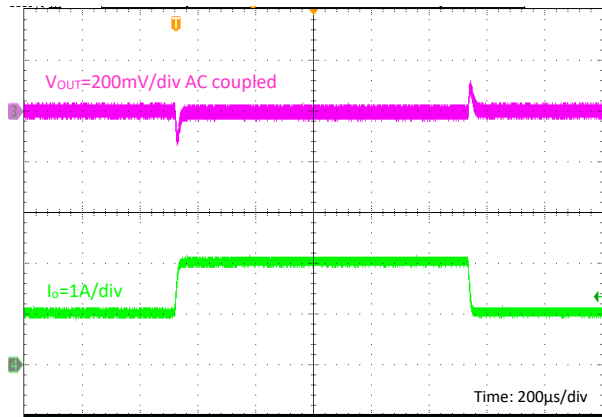

Input Power On

$V_{IN} = 12V, V_{OUT} = 3.3V, \text{No Load}$

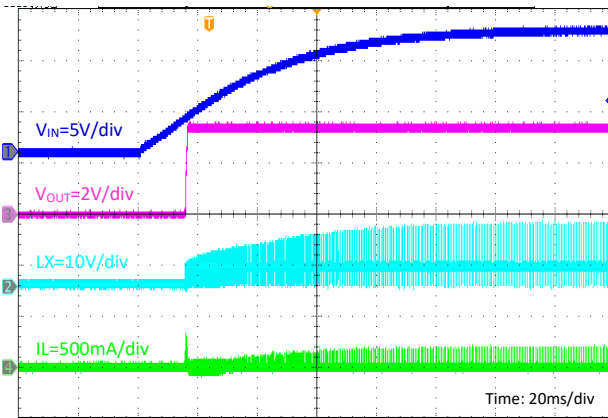

Input Power Down

$V_{IN} = 12V, V_{OUT} = 3.3V, \text{No Load}$

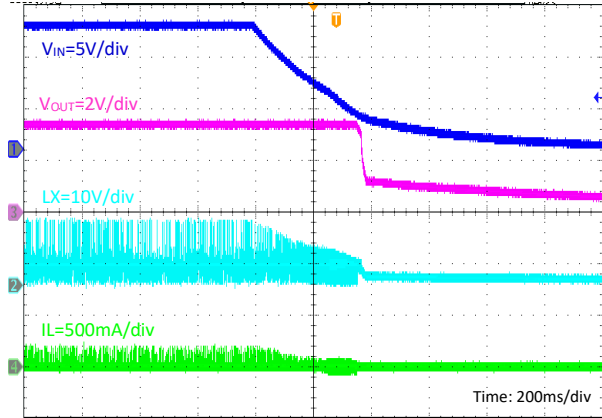

EN Enable Power On

$V_{IN} = 12V, V_{OUT} = 3.3V, I_o = 2A$

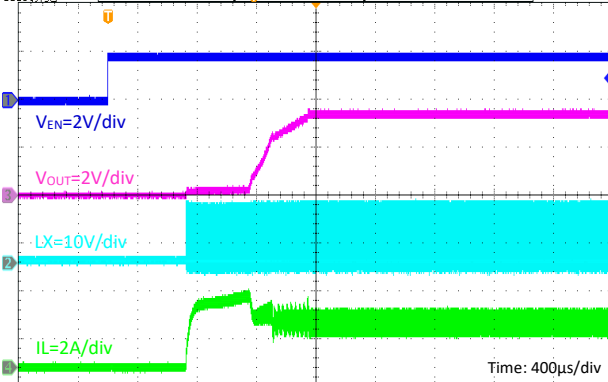

EN Disable Power down

$V_{IN} = 12V, V_{OUT} = 3.3V, I_o = 2A$

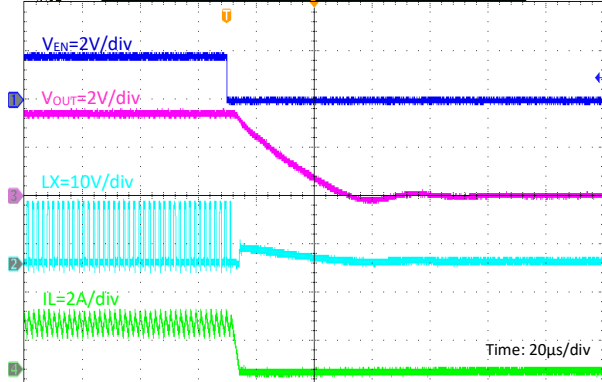

TYPICAL PERFORMANCE CHARACTERISTICS (continued)

EN Enable Power On

$V_{IN} = 12V$, $V_{OUT} = 3.3V$, No Load

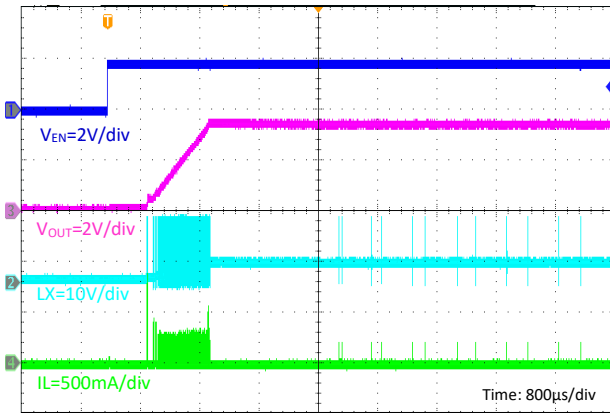

EN Disable Power down

$V_{IN} = 12V$, $V_{OUT} = 3.3V$, No Load

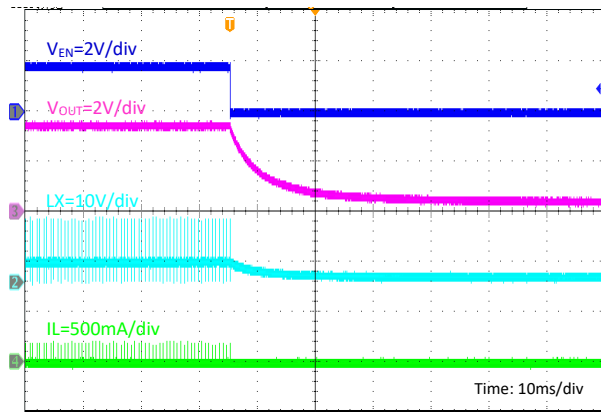

APPLICATION INFORMATION

Setting the Output Voltage

The external resistor divider is used to set the output voltage (see Typical Application on page 1). The feedback resistor R1 also sets the feedback loop bandwidth with the internal compensation capacitor. Choose R1 to be around 10kΩ for optimal transient response. R2 is then given by:

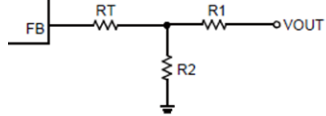
$$R_2 = \frac{R_1}{V_{out} / V_{FB} - 1}$$

Use a T-type network for when VOUT is low.

| Vout | R1(kΩ) | R2(kΩ) | RT(kΩ) |
|-------|--------|--------|--------|
| 5V | 40.2 | 7.26 | 75 |
| 3.3V | 40.2 | 12.13 | 75 |
| 2.5V | 40.2 | 17.73 | 100 |
| 1.8V | 40.2 | 29.71 | 120 |
| 1.2V | 20.5 | 36.05 | 249 |
| 1.05V | 10 | 26.84 | 300 |

Inductor Selection

A DC current rating of at least 25% percent higher than the maximum load current is recommended for most applications. Inductance value is related to inductor ripple current value, input voltage, output voltage setting and switching frequency. The inductor value can be derived from the following equation:

$$L = \frac{V_{OUT} \times (V_{IN} - V_{OUT})}{V_{IN} \times \Delta I_L \times f_{OSC}}$$

Where ΔI_L is inductor ripple current. Large value inductors result in lower ripple current and small value inductors result in high ripple current, so inductor value has effect on output voltage ripple value. DC resistance of inductor which has impact on efficiency of DC/DC converter should be taken into account when selecting the inductor. The maximum inductor peak current is:

$$I_{L(MAX)} = I_{LOAD} + \frac{\Delta I_L}{2}$$

Under light load conditions below 100mA, larger inductance is recommended for improved efficiency.

Output Capacitor Selection

The output capacitor (Co1) is required to maintain the DC output voltage. Ceramic, tantalum, or low ESR electrolytic capacitors are recommended. Low ESR capacitors are preferred to keep the output voltage ripple low. The output voltage ripple can be estimated by:

$$\Delta V_{OUT} = \frac{V_{OUT}}{f_s \times L} \times \left[1 - \frac{V_{OUT}}{V_{IN}} \right] \times \left[R_{ESR} + \frac{1}{8 \times f_s \times C_2} \right]$$

Where L is the inductor value and RESR is the equivalent series resistance (ESR) value of the output capacitor. In the case of ceramic capacitors, the impedance at the switching frequency is dominated by the capacitance. The output voltage ripple is mainly caused by the capacitance. For simplification, the output voltage ripple can be estimated by:

$$\Delta V_{OUT} = \frac{V_{OUT}}{8 \times f_s^2 \times L \times C_2} \times \left[1 - \frac{V_{OUT}}{V_{IN}} \right]$$

In the case of tantalum or electrolytic capacitors, the ESR dominates the impedance at the switching frequency. For simplification, the output ripple can be approximated to:

$$\Delta V_{OUT} = \frac{V_{OUT}}{f_s \times L} \times \left[1 - \frac{V_{OUT}}{V_{IN}} \right] \times R_{ESR}$$

The characteristics of the output capacitor also affect the stability of the regulation system. The MP1470 can be optimized for a wide range of capacitance and ESR values.

Layout Consideration

PCB layout is very important to achieve stable operation. It is highly recommended to duplicate EVB layout for optimum performance. If change is necessary, please follow these guidelines for reference.

- 1) Keep the path of switching current short and minimize the loop area formed by Input capacitor, high-side MOSFET and low-side MOSFET.
- 2) Bypass ceramic capacitors are suggested to be put close to the Vin Pin.
- 3) Ensure all feedback connections are short and direct. Place the feedback resistors and compensation components as close to the chip as possible.
- 4) VOUT, LX away from sensitive analog areas such as FB.
- 5) Connect IN, LX, and especially GND respectively to a large copper area to cool the chip to improve thermal performance and long-term reliability.

PACKAGE INFORMATION

SOT23-6

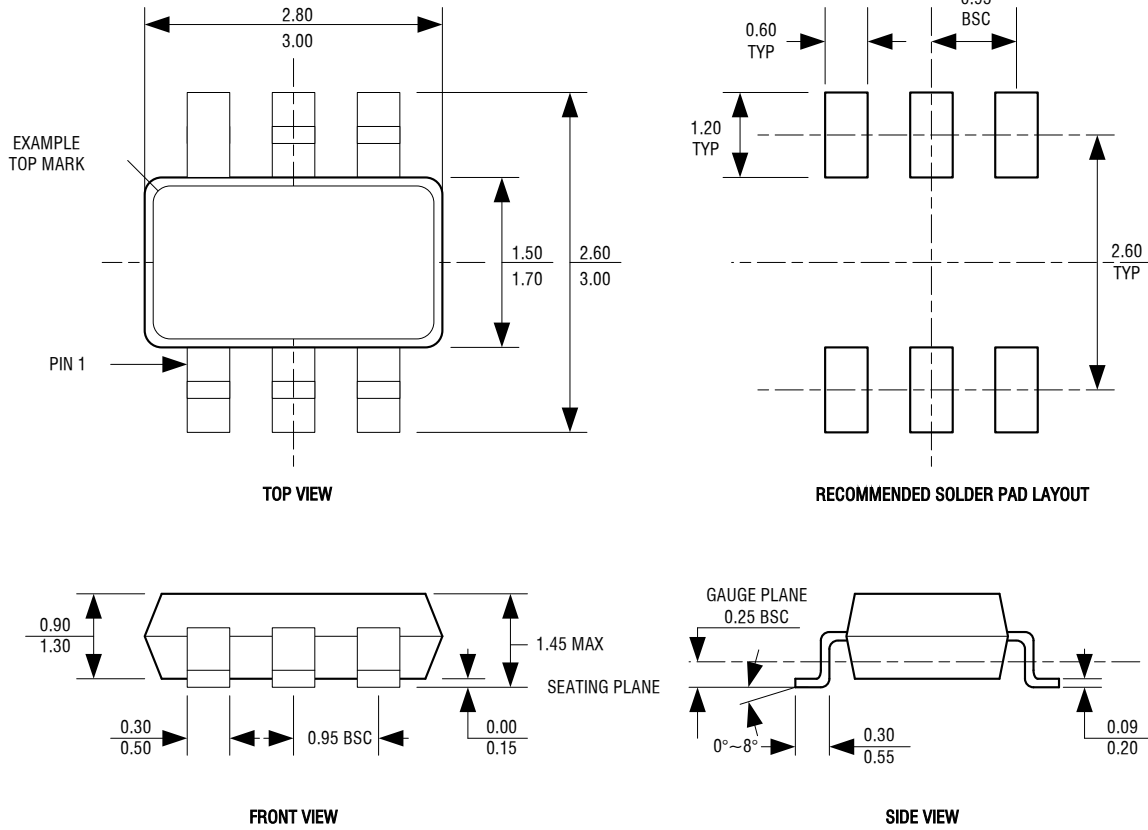

NOTE:
 1. DIMENSIONS ARE IN MILLIMETERS.
 2. DRAWING NOT TO SCALE.
 3. DIMENSIONS ARE INCLUSIVE OF PLATING.
 4. DIMENSIONS ARE EXCLUSIVE OF MOLD FLASH AND METAL BURR.

Order information

| Orderable Device | Package | Packing Option |
|------------------|----------|----------------|
| MSY8121BABC | SOT-23-6 | 3000PCS |

Attention

- Any and all MSKSEMI Semiconductor products described or contained herein do not have specifications that can handle applications that require extremely high levels of reliability, such as life-support systems, aircraft's control systems, or other applications whose failure can be reasonably expected to result in serious physical and/or material damage. Consult with your MSKSEMI Semiconductor representative nearest you before using any MSKSEMI Semiconductor products described or contained herein in such applications.
- MSKSEMI Semiconductor assumes no responsibility for equipment failures that result from using products at values that exceed, even momentarily, rated values (such as maximum ratings, operating condition ranges, or other parameters) listed in products specifications of any and all MSKSEMI Semiconductor products described or contained herein.
- Specifications of any and all MSKSEMI Semiconductor products described or contained herein stipulate the performance, characteristics, and functions of the described products in the independent state, and are not guarantees of the performance, characteristics, and functions of the described products as mounted in the customer's products or equipment. To verify symptoms and states that cannot be evaluated in an independent device, the customer should always evaluate and test devices mounted in the customer's products or equipment.
- MSKSEMI Semiconductor strives to supply high-quality high-reliability products. However, any and all semiconductor products fail with some probability. It is possible that these probabilistic failures could give rise to accidents or events that could endanger human lives, that could give rise to smoke or fire, or that could cause damage to other property. When designing equipment, adopt safety measures so that these kinds of accidents or events cannot occur. Such measures include but are not limited to protective circuits and error prevention circuits for safe design, redundant design, and structural design.
- In the event that any or all MSKSEMI Semiconductor products (including technical data, services) described or contained herein are controlled under any of applicable local export control laws and regulations, such products must not be exported without obtaining the export license from the authorities concerned in accordance with the above law.
- No part of this publication may be reproduced or transmitted in any form or by any means, electronic or mechanical, including photocopying and recording, or any information storage or retrieval system, or otherwise, without the prior written permission of MSKSEMI Semiconductor.
- Information (including circuit diagrams and circuit parameters) herein is for example only ; it is not guaranteed for volume production. MSKSEMI Semiconductor believes information herein is accurate and reliable, but no guarantees are made or implied regarding its use or any infringement of intellectual property rights or other rights of third parties.
- Any and all information described or contained herein are subject to change without notice due to product/technology improvement, etc. When designing equipment, refer to the "Delivery Specification" for the MSKSEMI Semiconductor product that you intend to use.