

# TDS:EMIC

## 拓電半導體

自主封測 品質把控 售後保障

WEB | [WWW.TDSEMIC.COM](http://WWW.TDSEMIC.COM)



電源管理



顯示驅動

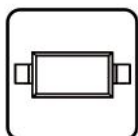

二三極管

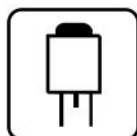

LDO穩壓器

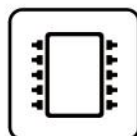

觸摸芯片

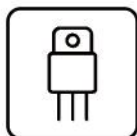

MOS管



運算放大器

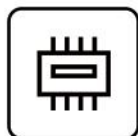

存儲芯片



MCU

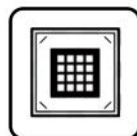

串口通信

# 1N4001-TD

產品規格說明書

## Features

- ◆ The plastic package carries Underwriters Laboratory Flammability Classification 94V-0
- ◆ Idea for printed circuit board
- ◆ Glass passivated Junction chip
- ◆ Low reverse leakage
- ◆ High forward surge current capability
- ◆ High temperature soldering guaranteed  
250 C/10 seconds at terminals

## Mechanical Data

**Case** : JEDEC DO-214AC/SMA Molded plastic body

**Terminals** : Solder plated, solderable per MIL-STD-750, Method 2026

**Polarity** : Polarity symbol marking on body

**Mounting Position** : Any

**Weight** : 0.0019ounce, 0.055 grams

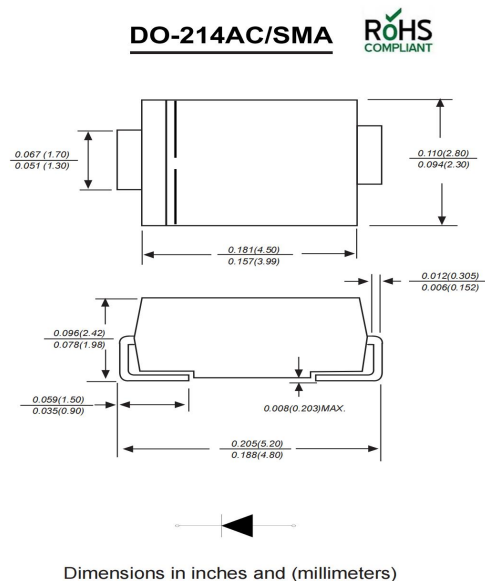

## Maximum Ratings And Electrical Characteristics

Ratings at 25°C ambient temperature unless otherwise specified.

Single phase half-wave 60Hz, resistive or inductive load, for capacitive load current derate by 20%.

Parameter	SYMBOLS	TSCTAIZI M1	TSCTAIZI M2	TSCTAIZI M3	TSCTAIZI M4	TSCTAIZI M5	TSCTAIZI M6	TSCTAIZI M7	UNITS
Marking Code									
Maximum repetitive peak reverse voltage	$V_{RRM}$	50	100	200	400	600	800	1000	V
Maximum RMS voltage	$V_{RMS}$	35	70	140	280	420	560	700	V
Maximum DC blocking voltage	$V_{DC}$	50	100	200	400	600	800	1000	V
Maximum average forward rectified current	$I_{(AV)}$	1							A
Peak forward surge current 8.3ms single half sine-wave superimposed on rated load	$I_{FSM}$	30							A
Maximum instantaneous forward voltage at 1.0A	$V_F$	1.1							V
Maximum DC reverse current at rated DC blocking voltage $T_A=25^{\circ}C$ $T_A=125^{\circ}C$	$I_R$	5 50							$\mu A$
Typical junction capacitance (NOTE 1)	$C_J$	15							pF
Typical thermal resistance (NOTE 2)	$R_{\theta JA}$	75							$^{\circ}C/W$
Operating junction and storage temperature range	$T_J, T_{STG}$	-55 to +150							$^{\circ}C$

**Note:** 1. Measured at 1MHz and applied reverse voltage of 4.0V D.C.  
2. P.C.B. mounted with 2.0x2.0" (2.54x2.54cm) copper pad areas

## Ratings And Characteristic Curves

Fig.1 Forward Current Derating Curve

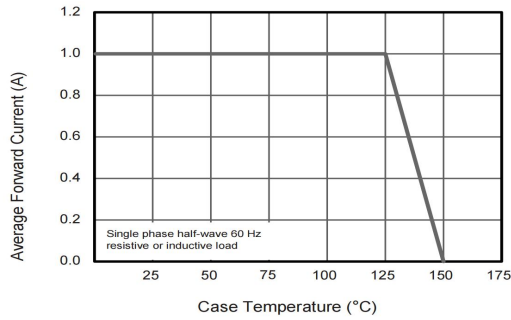

Fig.2 Typical Instaneous Reverse Characteristics

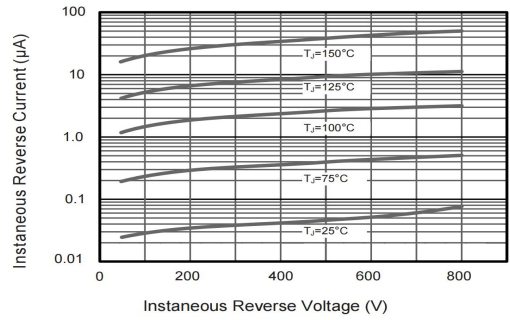

Fig.3 Typical Forward Characteristic

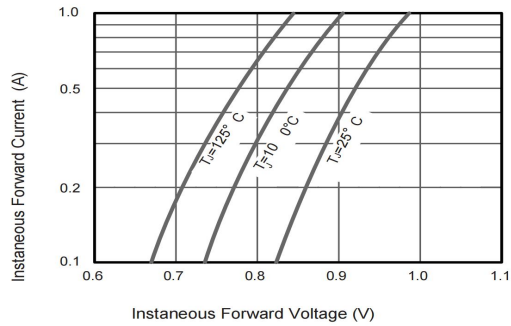

Fig.4 Typical Junction Capacitance

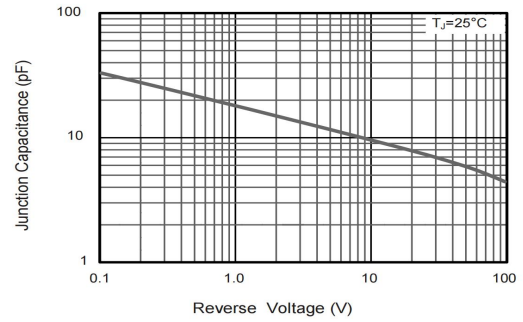
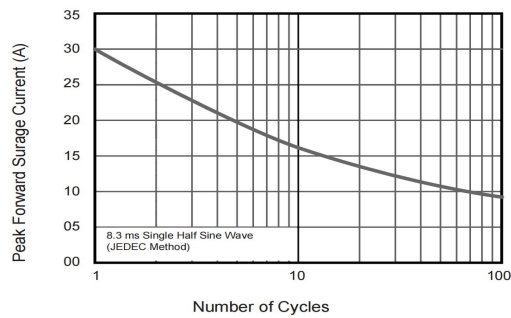
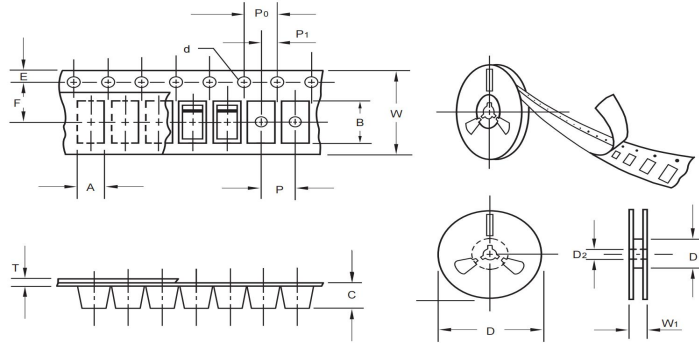

Fig.5 Maximum Non-Repetitive Peak Forward Surge Current



The curve above is for reference only.

## Packing information



unit:mm

Item	Symbol	Tolerance	SMA
Carrier width	A	0.1	2.80
Carrier length	B	0.1	5.33
Carrier depth	C	0.1	2.36
Sprocket hole	d	0.05	1.50
13" Reel outside diameter	D	2.0	330.00
13" Reel inner diameter	D <sub>1</sub>	min	50.00
7" Reel outside diameter	D	2.0	178.00
7" Reel inner diameter	D <sub>1</sub>	min	62.00
Feed hole diameter	D <sub>2</sub>	0.5	13.00
Sprocket hole position	E	0.1	1.75
Punch hole position	F	0.1	5.50
Punch hole pitch	P	0.1	4.00
Sprocket hole pitch	P <sub>0</sub>	0.1	4.00
Embossment center	P <sub>1</sub>	0.1	2.00
Overall tape thickness	T	0.1	0.28
Tape width	W	0.3	12.00
Reel width	W <sub>1</sub>	1.0	18.00

Note: Devices are packed in accordance with EIA standard RS-481-A and specifications listed above.

## Reel packing

PACKAGE	REEL SIZE	REEL (pcs)	COMPONENT SPACING (m/m)	BOX (pcs)	INNER BOX (m/m)	REEL DIA. (m/m)	CARTON SIZE (m/m)	CARTON (pcs)	APPROX. GROSS WEIGHT (kg)
SMA	7"	2,000	4.0	4,000	183*155*183	178	382*356*392	80,000	16.0
SMA	11"	5,000	4.0	10,000	290*290*38	330	310*310*360	80,000	11.0
SMA	13"	7,500	4.0	15,000	335*335*38	330	350*330*360	120,000	14.5

## Suggested Pad Layout

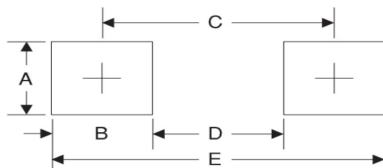

Symbol	Unit (mm)	Unit (inch)
A	1.68	0.066
B	1.52	0.060
C	3.90	0.154
D	2.41	0.095
E	5.45	0.215