

1

2

3

4

A

A

B

B

C

C

D

D

E

E

F

F

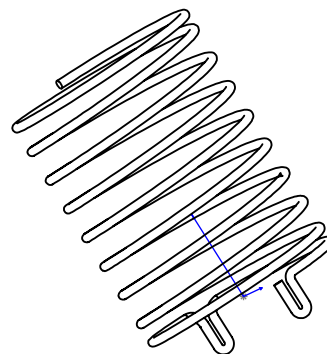
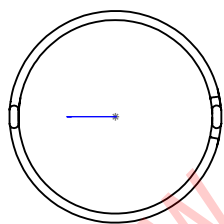
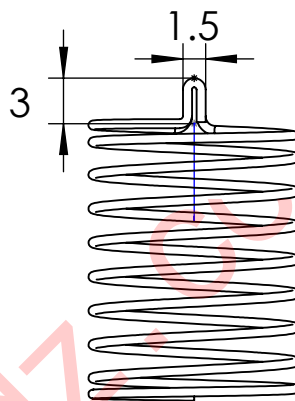
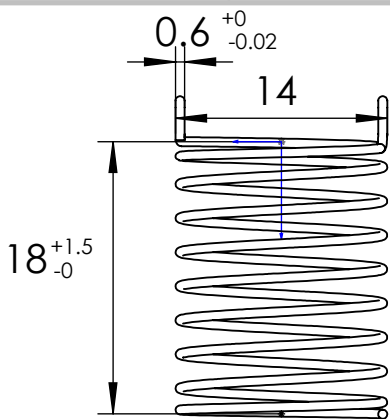

www.xwxwdz.com

Technical requirements:

- 1、 Unit: mm
- 2、 Wire diameter: 0.6
- 3、 Material: Nickel Plated Steel-Wire, meet ROHS
- 4、 Style: straight cylinder double pin
- 5、 Technics: High-Temperature Heat Treatment at 260°C
- 6、 Size tolerance: The tolerance of unmarked parts is $\pm 0.25\text{mm}$
- 7、 No dirty surface, no bad material
- 8、 Contact number: 13459252012、 0592-5216722
- 9、 Mode: F14-18-0.6-1.5UU
- 10、 Salt spray test: five percent salt spray test meets 24hours
- 11、 Package: by bag, MPQ: 500PCS/bag

| | | | | | | | | | | |
|----|----|----|-------|----|-----|------|----|-----|---------------|--|
| | | | | | | 碳钢线 | | | 厦门市芯网电子科技有限公司 | |
| | | | | | | | | | | |
| 标记 | 处数 | 分区 | 更改文件号 | 签名 | 年月日 | 阶段标记 | 重量 | 比例 | | |
| 设计 | | | | | | s | | 2:1 | | |
| 校核 | | | | | | | | | | |
| 批准 | | | | | | | | | | |
| | | | | | | | | | | |

1

2

3

4