

1. General Description

The 74AHC245 and 74AHCT245 are 8-bit transceiver with 3-state outputs. The device features an output enable (\overline{OE}) and send/receive (DIR) for direction control. A HIGH on \overline{OE} causes the outputs to assume a high-impedance OFF-state. Inputs are overvoltage tolerant. This feature allows the use of these devices as translators in mixed voltage environments.

2. Features and Benefits

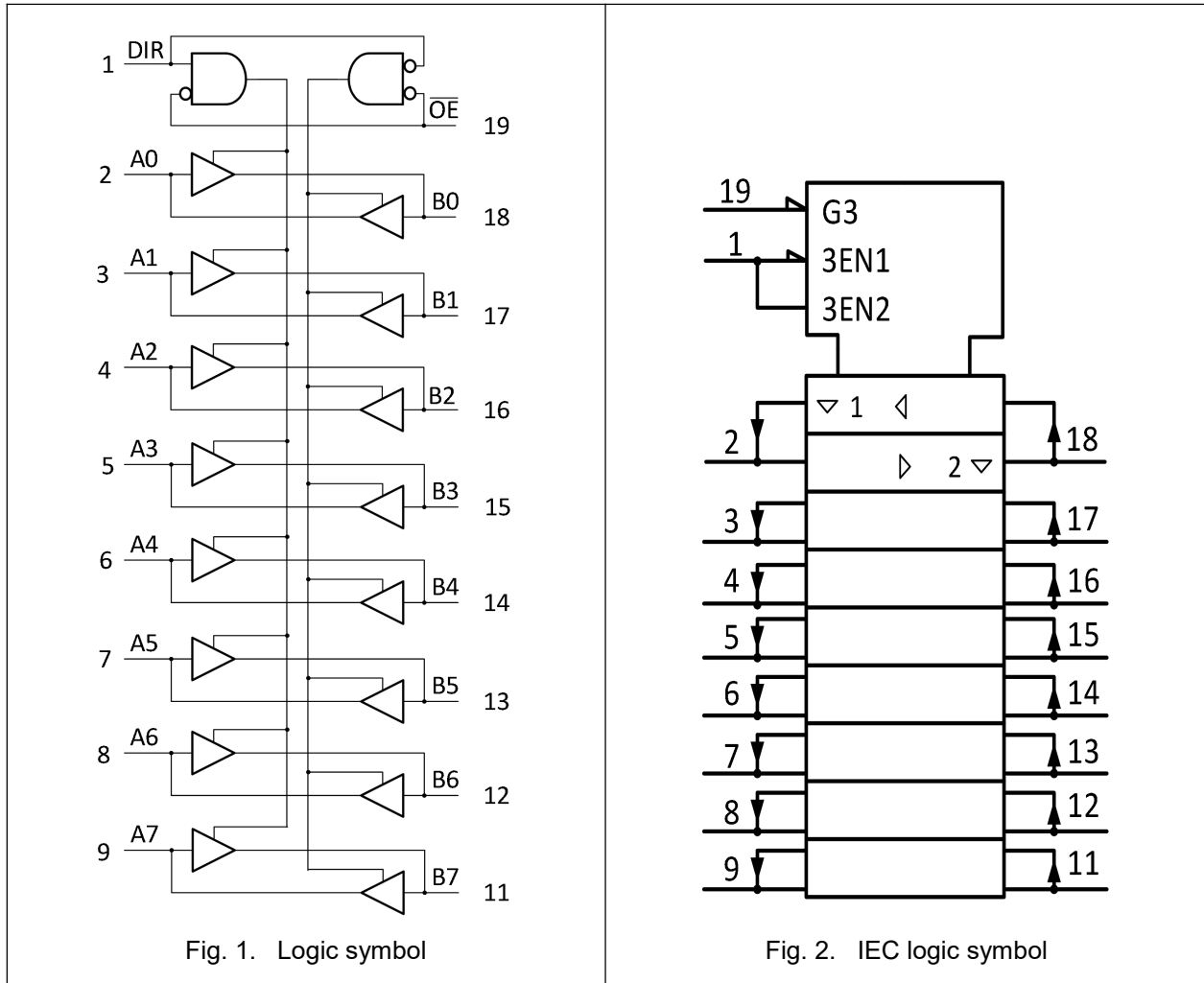
- Wide supply voltage range from 2.0 V to 5.5 V
- Balanced propagation delays
- All inputs have Schmitt-trigger action
- Overvoltage tolerant inputs to 5.5 V
- High noise immunity
- CMOS low power dissipation
- Input levels:
 - For 74AHC245: CMOS level
 - For 74AHCT245: TTL level
- ESD protection:
 - HBM: ANSI/ESDA/JEDEC JS-001 class 3A exceeds 4000 V
 - CDM: ANSI/ESDA/JEDEC JS-002 class C3 exceeds 2000 V
- Latch-up performance exceeds 250 mA
- Multiple package options

3. Ordering Information

Table 1. Ordering information

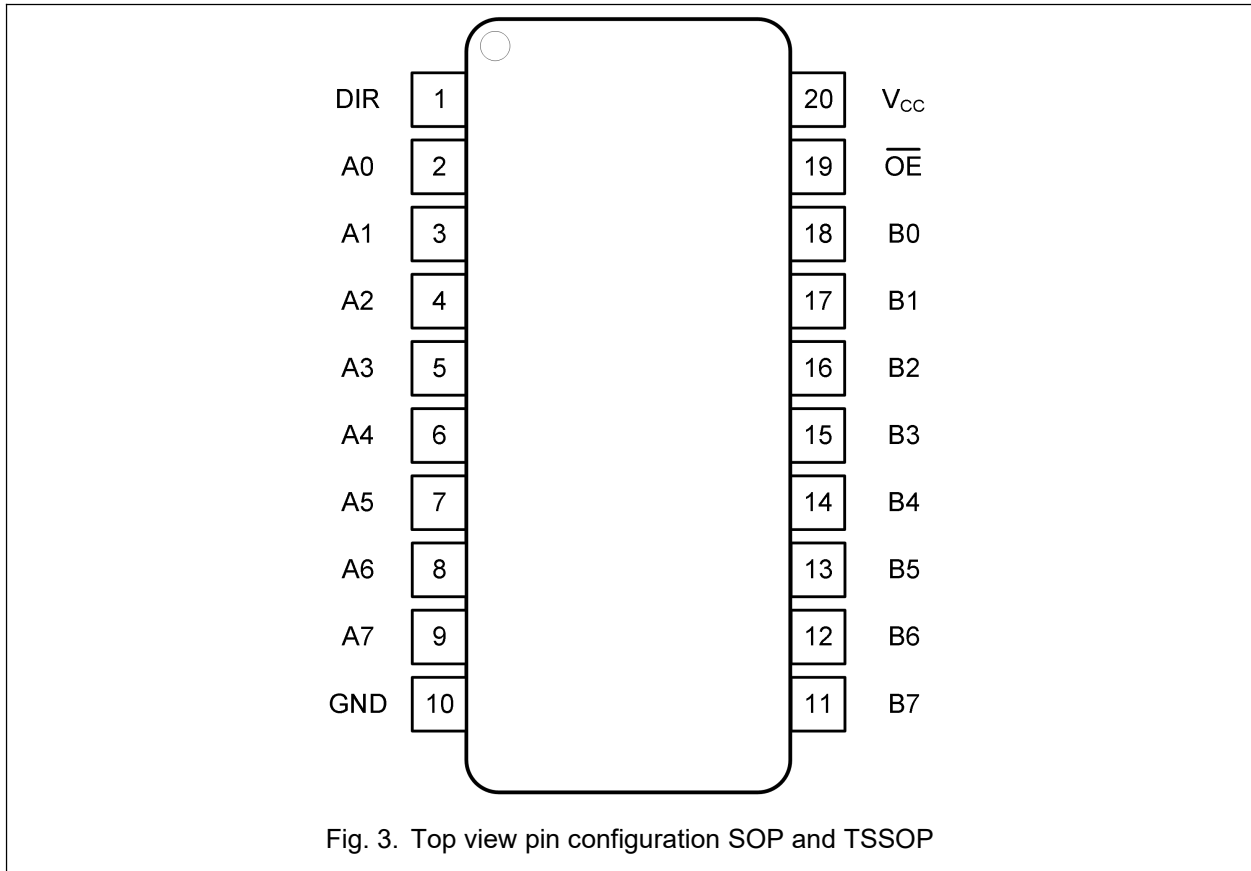
Type number	Package		
	Name	Description	Quantity
74AHC245D	SOP-20L	plastic small outline package; 20 leads;body width 7.5 mm	2000
74AHCT245D			
74AHC245PW	TSSOP-20L	plastic thin shrink small outline package; 20 leads;body width 4.4 mm	2500
74AHCT245PW			

4. Function Diagram



5. Pinning Information

5.1. Pinning



5.2. Pin description

Table 2. Pin description

Symbol	Pin	Description
DIR	1	Direction control
A0, A1, A2, A3, A4, A5, A6, A7	2, 3, 4, 5, 6, 7, 8, 9	Data input/output
GND	10	Ground (0 V)
B7, B6, B5, B4, B3, B2, B1, B0	11, 12, 13, 14, 15, 16, 17, 18	Data input/output
\overline{OE}	19	Output enable input (active LOW)
V_{CC}	20	Supply voltage

6. Functional Description

Table 3. Function table

H = HIGH voltage level; L = LOW voltage level; X = don't care; Z = high-impedance OFF-state.

Input		Input/output	
\overline{OE}	DIR	An	Bn
L	L	A = B	input
L	H	input	B = A
H	X	Z	Z

7. Absolute Maximum Ratings

Stresses exceeding the absolute maximum ratings may damage the device. The device may not function or be operable above the recommended operating conditions and stressing the parts to these levels is not recommended. In addition, extended exposure to stresses above the recommended operating conditions may affect device reliability. The absolute maximum ratings are stress ratings only.

Table 4. Absolute Maximum Ratings

In accordance with the Absolute Maximum Rating System (IEC 60134). Voltages are referenced to GND.

Symbol	Parameter	Conditions	Min	Max	Unit
V_{CC}	supply voltage		-0.5	7.0	V
V_I	input voltage		-0.5	7.0	V
I_{IK}	input clamping current	$V_I < 0\text{ V}$ [1]	-20		mA
I_{OK}	output clamping current	$V_O > V_{CC}$ or $V_O < 0\text{ V}$ [1]		± 20	mA
I_O	output current	$V_O = 0\text{ V}$ to V_{CC}		± 25	mA
I_{CC}	supply current			75	mA
I_{GND}	ground current		-75		mA
P_{tot}	total power dissipation			500	mW
T_{stg}	storage temperature		-65	150	°C

[1] The input and output voltage ratings may be exceeded if the input and output current ratings are observed.

8. Recommended Operating Conditions

The Recommended Operating Conditions table defines the conditions for actual device operation. Recommended operating conditions are specified to ensure optimal performance to the datasheet specifications. EnergyMath does not recommend exceeding them or designing to Absolute Maximum Ratings.

Table 5. Recommended Operating Conditions

Voltages are referenced to GND(gnd = 0 V).

Symbol	Parameter	Conditions	74AHC245			74AHCT245			Unit
			Min	Typ	Max	Min	Typ	Max	
V _{CC}	supply voltage		2.0	5.0	5.5	4.5	5.0	5.5	V
V _I	input voltage		0		5.5	0		5.5	V
V _O	output voltage		0		V _{CC}	0		V _{CC}	V
T _{amb}	ambient temperature		-40	25	125	-40	25	125	°C
Δt/ΔV	input transition rise and fall rate	V _{CC} = 3.3 V ± 0.3 V			50				ns/V
		V _{CC} = 5.0 V ± 0.5 V			10			5	ns/V

9. Static Characteristics

Table 6. Static characteristics

At recommended operating conditions. Voltages are referenced to GND (ground = 0 V). Typical values measured at $T_{amb} = 25^{\circ}\text{C}$ (unless otherwise noted).

Symbol	Parameter	Conditions	-40 °C to +85 °C			-40 °C to +125 °C		Unit
			Min	Typ	Max	Min	Max	
74AHC245								
V_{IH}	HIGH-level input voltage	$V_{CC} = 2.0\text{ V}$	1.5			1.5		V
		$V_{CC} = 3.0\text{ V}$	2.1			2.1		V
		$V_{CC} = 5.5\text{ V}$	3.85			3.85		V
V_{IL}	LOW-level input voltage	$V_{CC} = 2.0\text{ V}$			0.5		0.5	V
		$V_{CC} = 3.0\text{ V}$			0.9		0.9	V
		$V_{CC} = 5.5\text{ V}$			1.65		1.65	V
V_{OH}	HIGH-level output voltage	$V_I = V_{IH}$ or V_{IL}						
		$I_O = -50\ \mu\text{A}; V_{CC} = 2.0\text{ V}$	1.9	2.0		1.9		V
		$I_O = -50\ \mu\text{A}; V_{CC} = 3.0\text{ V}$	2.9	3.0		2.9		V
		$I_O = -50\ \mu\text{A}; V_{CC} = 4.5\text{ V}$	4.4	4.5		4.4		V
		$I_O = -4.0\text{ mA}; V_{CC} = 3.0\text{ V}$	2.48			2.4		V
		$I_O = -8.0\text{ mA}; V_{CC} = 4.5\text{ V}$	3.8			3.7		V
V_{OL}	LOW-level output voltage	$V_I = V_{IH}$ or V_{IL}						
		$I_O = 50\ \mu\text{A}; V_{CC} = 2.0\text{ V}$		0	0.1		0.1	V
		$I_O = 50\ \mu\text{A}; V_{CC} = 3.0\text{ V}$		0	0.1		0.1	V
		$I_O = 50\ \mu\text{A}; V_{CC} = 4.5\text{ V}$		0	0.1		0.1	V
		$I_O = 4.0\text{ mA}; V_{CC} = 3.0\text{ V}$			0.44		0.55	V
		$I_O = 8.0\text{ mA}; V_{CC} = 4.5\text{ V}$			0.44		0.55	V
I_I	input leakage current	$V_I = 5.5$ or GND ; $V_{CC} = 0\text{ V to }5.5\text{ V}$			1.0		2.0	μA
I_{OZ}	OFF-state output current	$V_I = V_{IH}$ or $V_{IL}; V_{CC} = 5.5\text{ V};$ $V_O = V_{CC}$ or GND			± 2.5		± 10.0	μA
I_{CC}	supply current	$V_I = V_{CC}$ or GND ; $I_O = 0\text{ A};$ $V_{CC} = 5.5\text{ V}$			40		80	μA
C_I	input capacitance			3.0	10		10	pF
C_O	output capacitance			4.0				pF

74AHC245; 74AHCT245

Octal buffer/line driver; 3-state

Symbol	Parameter	Conditions	-40 °C to +85 °C			-40 °C to +125 °C		Unit
			Min	Typ	Max	Min	Max	
74AHCT245								
V_{IH}	HIGH-level input voltage	$V_{CC} = 4.5 \text{ V to } 5.5 \text{ V}$	2.0			2.0		V
V_{IL}	LOW-level input voltage	$V_{CC} = 4.5 \text{ V to } 5.5 \text{ V}$			0.8		0.8	V
V_{OH}	HIGH-level output voltage	$V_I = V_{IH} \text{ or } V_{IL}; V_{CC} = 4.5 \text{ V}$						
		$I_O = -50 \mu\text{A};$	4.4	4.5		4.4		V
		$I_O = -8.0 \text{ mA};$	3.8			3.7		V
V_{OL}	LOW-level output voltage	$V_I = V_{IH} \text{ or } V_{IL}; V_{CC} = 4.5 \text{ V}$						
		$I_O = 50 \mu\text{A};$		0	0.1		0.1	V
		$I_O = 8.0 \text{ mA};$			0.44		0.45	V
I_I	input leakage current	$V_I = 5.5 \text{ V or GND}; V_{CC} = 0 \text{ V to } 5.5 \text{ V}$			1.0		2.0	μA
I_{OZ}	OFF-state output current	$V_I = V_{IH} \text{ or } V_{IL}; V_{CC} = 5.5 \text{ V}; V_O = V_{CC} \text{ or GND}$			± 2.5		± 10.0	μA
I_{CC}	supply current	$V_I = V_{CC} \text{ or GND}; I_O = 0 \text{ A}; V_{CC} = 5.5 \text{ V}$			40		80	μA
ΔI_{CC}	additional supply current	per pin ; $V_I = V_{CC} - 2.1 \text{ V}; I_O = 0 \text{ A};$ other inputs at V_{CC} or GND; $V_{CC} = 4.5 \text{ V to } 5.5 \text{ V}$			1.5		1.5	mA
C_I	input capacitance			3.0	10		10	pF
C_O	output capacitance			4.0				pF

10. Dynamic Characteristics

Table 7. Dynamic characteristics

Voltages are referenced to GND (ground = 0 V); for test circuit see Fig. 6. Typical values measured at $T_{amb} = 25^{\circ}\text{C}$ (unless otherwise noted).

Symbol	Parameter	Conditions	-40 °C to +85 °C			-40 °C to +125 °C		Unit
			Min	Typ[1]	Max	Min	Max	
74AHC245								
t_{pd}	propagation delay	An to Bn; Bn to An; see Fig. 4 [1]						
		$V_{CC} = 3.0\text{ V to }3.6\text{ V}, C_L = 15\text{ pF}$	1.0	7.0	13.5	1.0	15.0	ns
		$V_{CC} = 4.5\text{ V to }5.5\text{ V}, C_L = 15\text{ pF}$	1.0	5.0	8.5	1.0	9.5	ns
t_{en}	enable time	\overline{OE} to An; \overline{OE} to Bn; see Fig. 5 [2]						
		$V_{CC} = 3.0\text{ V to }3.6\text{ V}, C_L = 15\text{ pF}$	1.0	7.5	16.0	1.0	18.0	ns
		$V_{CC} = 4.5\text{ V to }5.5\text{ V}, C_L = 15\text{ pF}$	1.0	5.5	10.5	1.0	12.0	ns
t_{dis}	disable time	\overline{OE} to An; \overline{OE} to Bn; see Fig. 5 [2]						
		$V_{CC} = 3.0\text{ V to }3.6\text{ V}, C_L = 15\text{ pF}$	1.0	10.0	16.0	1.0	17.5	ns
		$V_{CC} = 4.5\text{ V to }5.5\text{ V}, C_L = 15\text{ pF}$	1.0	7.0	10.5	1.0	11.5	ns
C_{PD}	power dissipation capacitance	$V_I = \text{GND to }V_{CC}, C_L = 15\text{ pF};$ $f_i = 1\text{ MHz}$ [3]		10				pF

Symbol	Parameter	Conditions	-40 °C to +85 °C			-40 °C to +125 °C		Unit
			Min	Typ[1]	Max	Min	Max	
74AHCT245								
t_{pd}	propagation delay	An to Bn; Bn to An; see Fig. 4 [1]						
		$V_{CC} = 4.5 \text{ V to } 5.5 \text{ V}, C_L = 15 \text{ pF}$	1.0	5.0	9.5	1.0	10.5	ns
t_{en}	enable time	\overline{OE} to An; \overline{OE} to Bn; see Fig. 5 [2]						
		$V_{CC} = 4.5 \text{ V to } 5.5 \text{ V}, C_L = 15 \text{ pF}$	1.0	5.5	13.0	1.0	14.5	ns
t_{dis}	disable time	\overline{OE} to An; \overline{OE} to Bn; see Fig. 5 [2]						
		$V_{CC} = 4.5 \text{ V to } 5.5 \text{ V}, C_L = 15 \text{ pF}$	1.0	7.0	13.0	1.0	14.5	ns
C_{PD}	power dissipation capacitance	$V_i = \text{GND to } V_{CC}, C_L = 15 \text{ pF};$ $f_i = 1 \text{ MHz}$ [3]		12				pF

[1] Typical values are measured at nominal supply voltage ($V_{CC} = 3.3 \text{ V}$ and $V_{CC} = 5.0 \text{ V}$).

[2] t_{pd} is the same as t_{PLH} and t_{PHL} .

t_{en} is the same as t_{PZL} and t_{PZH} .

t_{dis} is the same as t_{PLZ} and t_{PHZ} .

[3] C_{PD} is used to determine the dynamic power dissipation P_D (μW).

$P_D = C_{PD} \times V_{CC}^2 \times f_i + \sum (C_L \times V_{CC}^2 \times f_o)$ where:

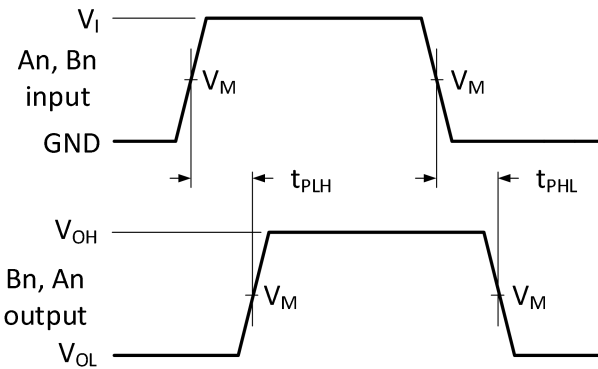
f_i = input frequency in MHz;

f_o = output frequency in MHz;

C_L = output load capacitance in pF;

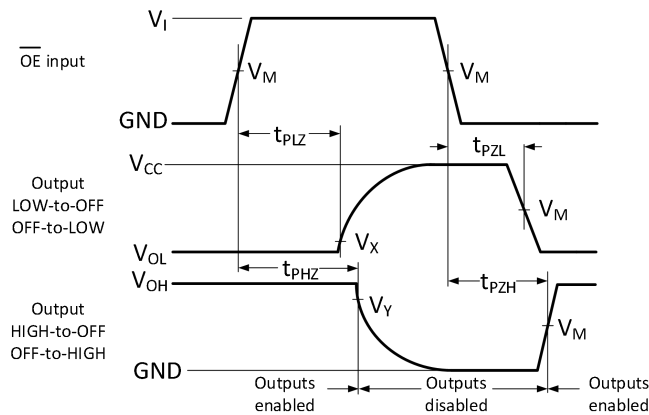
V_{CC} = supply voltage in Volts.

10.1. Waveforms and test circuit



Measurement points are given in Table 8.
 V_{OL} and V_{OH} are typical output voltage levels that occur with the output load.

Fig. 4. The input An/Bn to output Bn/An propagation delays

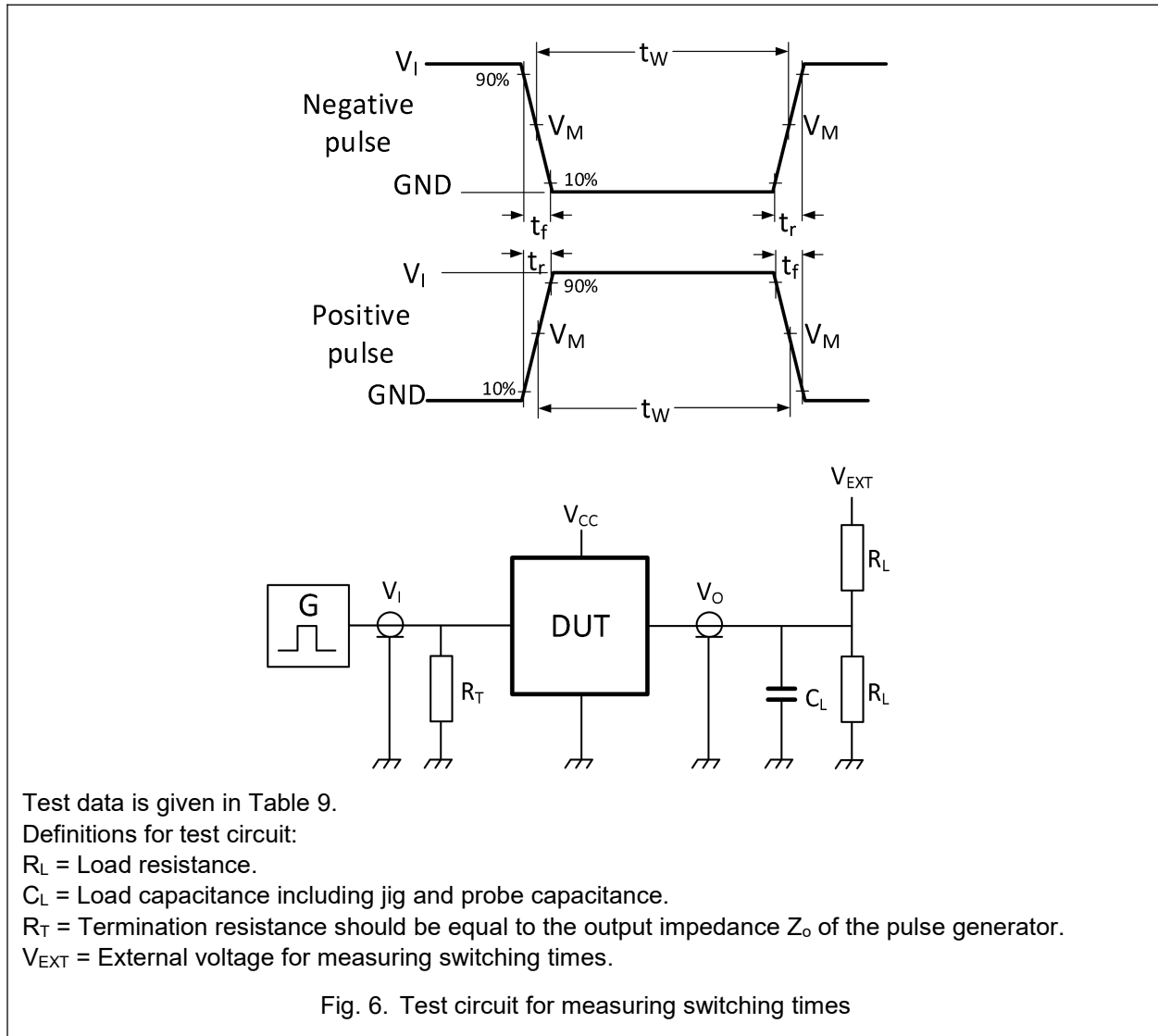


Measurement points are given in Table 8.
 V_{OL} and V_{OH} are typical output voltage levels that occur with the output load.

Fig. 5. 3-state enable and disable times

Table 8. Measurement points

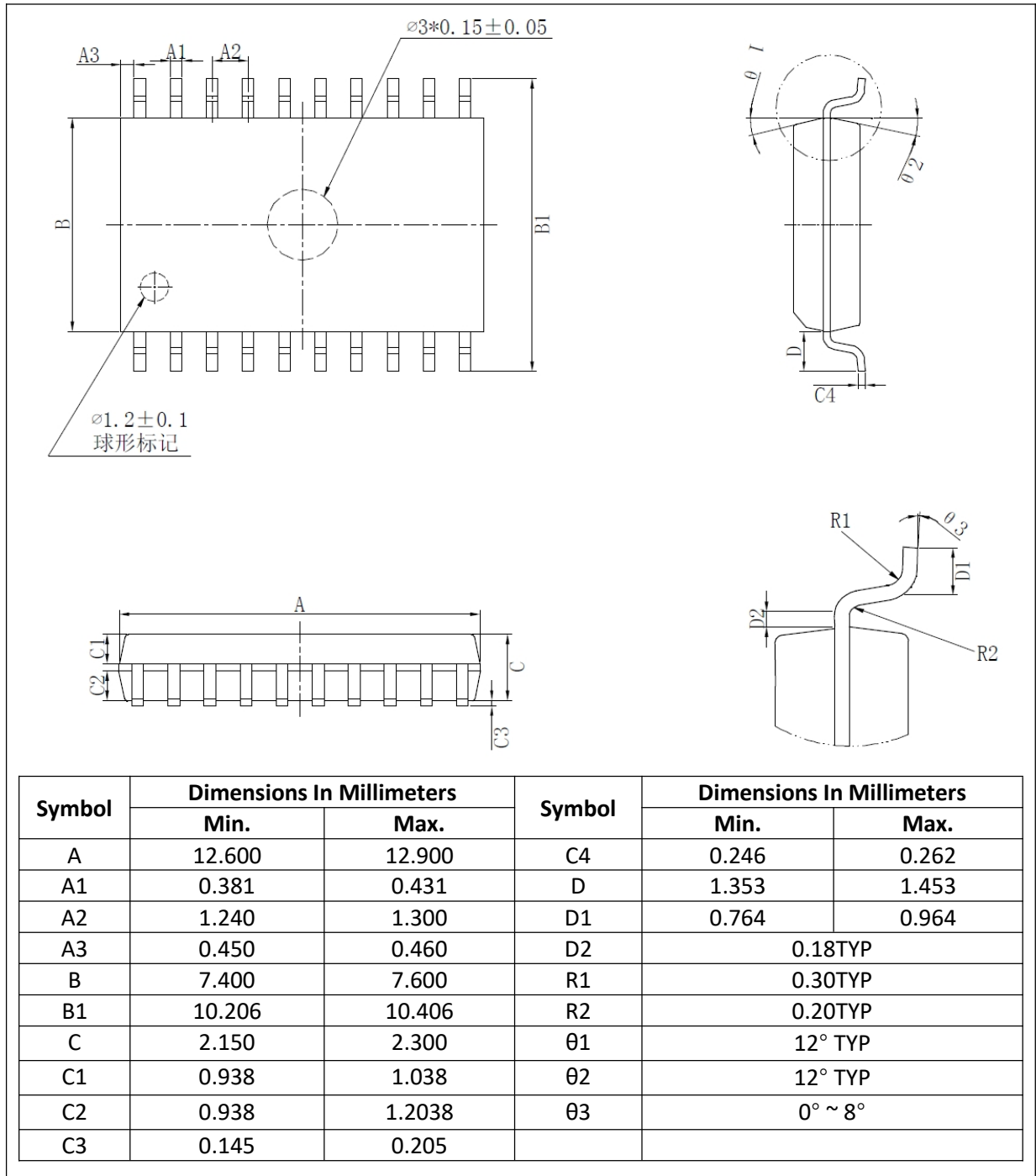
Type	Input	Output		
	V_M	V_M	V_X	V_Y
74AHC245	$0.5V_{CC}$	$0.5V_{CC}$	$V_{OL} + 0.3 V$	$V_{OH} - 0.3 V$
74AHCT245	1.5 V	$0.5V_{CC}$	$V_{OL} + 0.3 V$	$V_{OH} - 0.3 V$

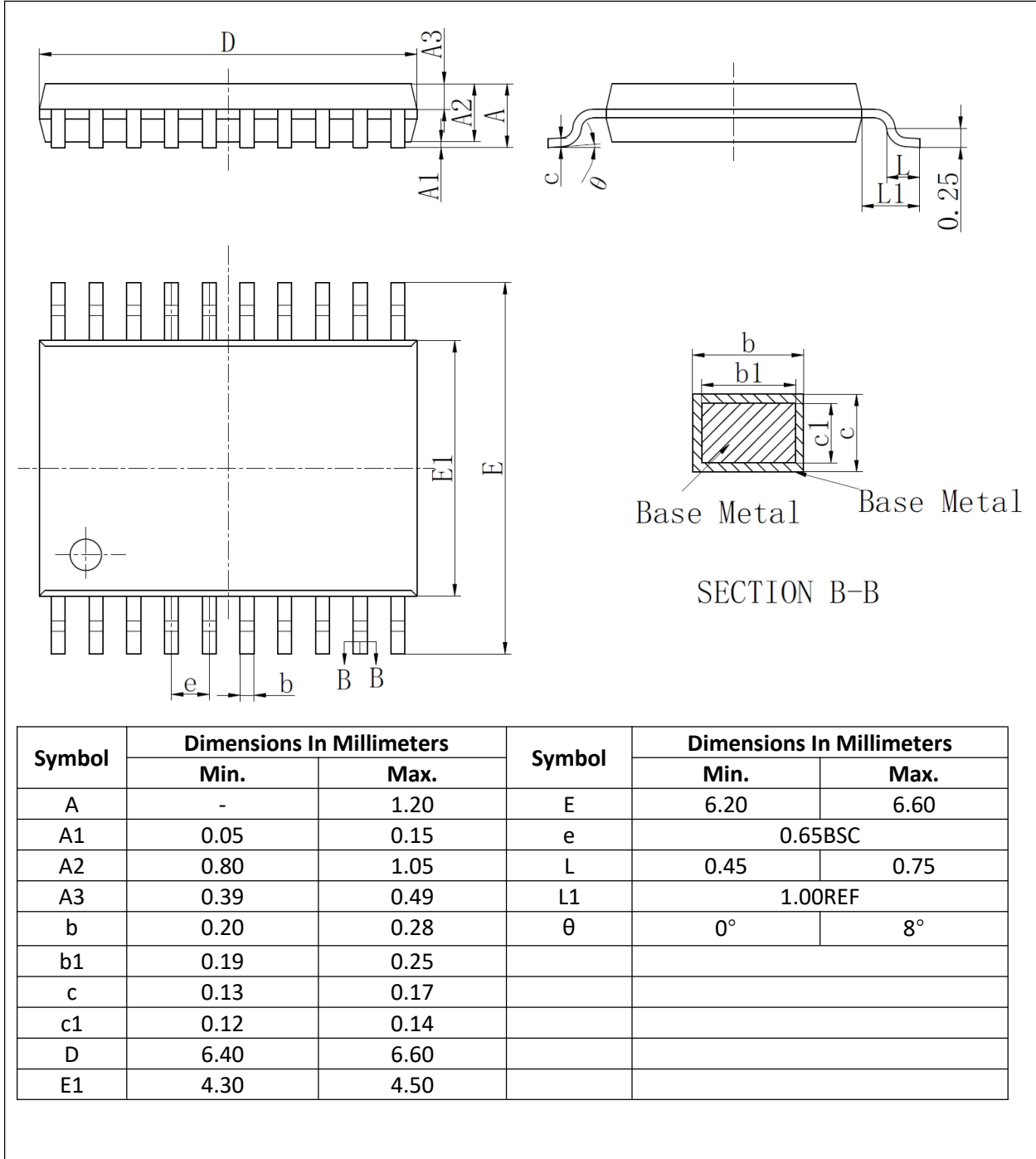

Table 9. Test data

Type	Input		Load		V_{EXT}		
	V_I	$t_r = t_f$	C_L	R_L	t_{PLH}, t_{PHL}	t_{PZH}, t_{PHZ}	t_{PZL}, t_{PLZ}
74AHC245	V_{CC}	3.0 ns	15 pF	500 Ω	open	GND	$2V_{CC}$
74AHCT245	3.0V	3.0 ns	15 pF	500 Ω	open	GND	$2V_{CC}$

11. Package Outline

SOP-20L



TSSOP-20L


12. Tape and Reel Information

12.1. Carrier tape dimensions

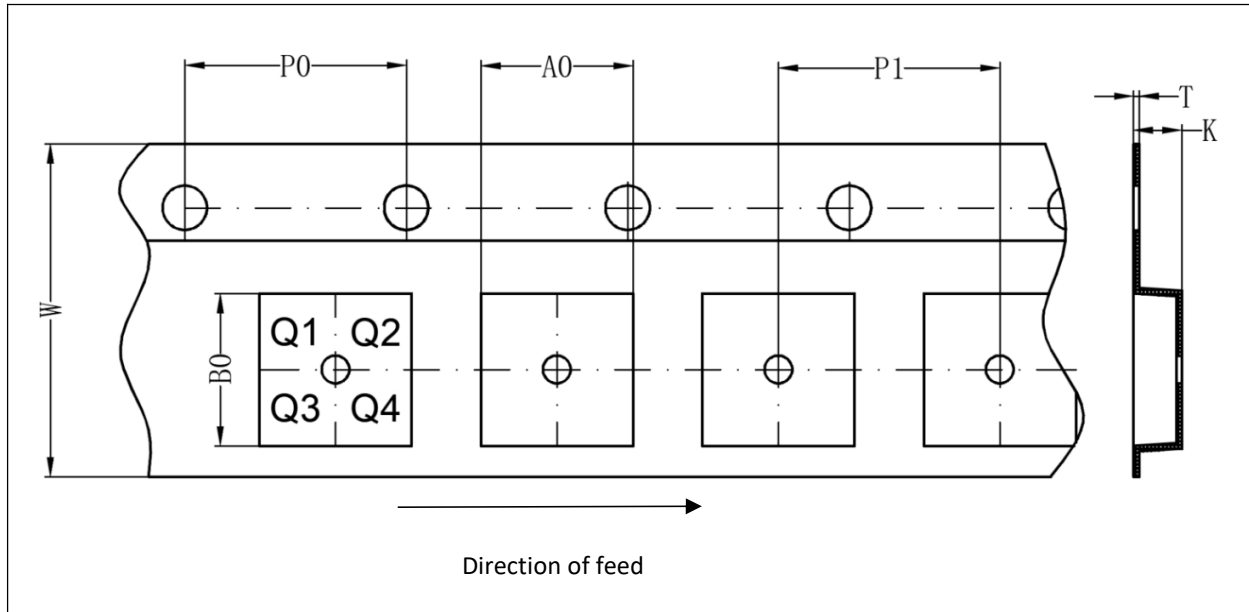


Table 10. Carrier tape dimensions

Package version	A0(mm)	B0(mm)	K0(mm)	T(mm)	P1(mm)	W(mm)	P0(mm)	PIN 1
SOP-20L	10.65	13.2	3.2	0.3	12	24	4	Q1
TSSOP-20L	6.85	6.85	1.7	0.22	8	12	4	Q1

12.2. Reel and box dimensions

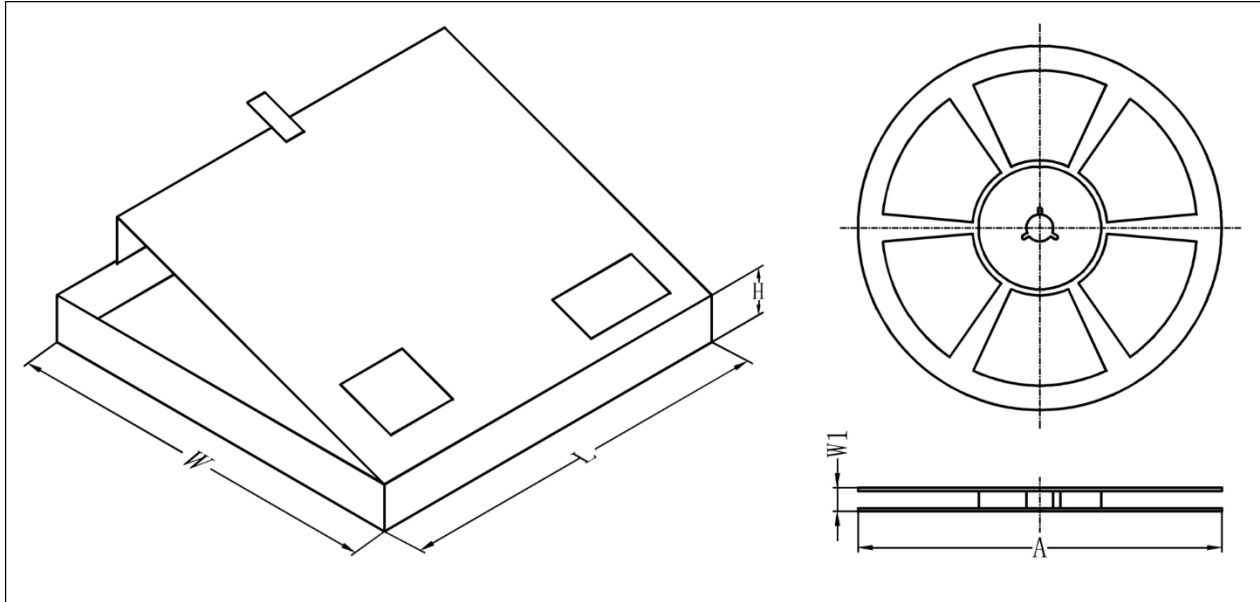


Table 11. Dimensions and quantities

Package version	Type NO. ending	Reel Dimension A (mm)	Reel Width W1 (mm)	SPQ (pcs) [1]	Reels per box	Outer box dimensions L×W×H(mm) [2]
SOP-20L	D	330	30.4	2000	1	358x340x50
TSSOP-20L	PW	330	18.4	2500	1	358x340x50

[1] Packing quantity dependent on specific product type. Please contact your local Energymath representative for ordering.

[2] Dimensions for reference only.

13. Abbreviations

Table 12. Abbreviations

Acronym	Description
CMOS	Complementary Metal-Oxide Semiconductor
DUT	Device Under Test
ESD	ElectroStatic Discharge
HBM	Human Body Model
CDM	Charged Device Model
TTL	Transistor-Transistor Logic

14. Revision History

Table 13. Revision history

Document ID	Release Date	Data sheet status	Change notice	Supersedes
74AHC_AHCT245 Rev. 1.0	Sep 03, 2025	Draft datasheet		