



General Description

The HSU0117 uses advanced trench MOSFET technology to provide excellent $R_{DS(ON)}$ and gate charge for use in a wide variety of other applications.

The HSU0117 meet the RoHS and Green Product requirement, 100% EAS guaranteed with full function reliability approved.

Features

- 100% EAS Guaranteed
- Green Device Available
- Super Low Gate Charge
- Excellent CdV/dt effect decline
- Advanced high cell density Trench Technology

Product Summary

V_{DS}	-100	V
$R_{DS(ON),typ}$	40	m Ω
I_D	-25	A

TO-252 Pin Configuration

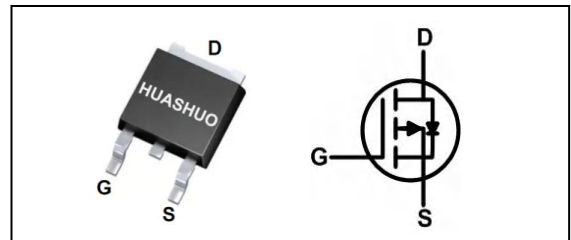

Absolute Maximum Ratings

Symbol	Parameter	Rating	Units
V_{DS}	Drain-Source Voltage	-100	V
V_{GS}	Gate-Source Voltage	± 20	V
$I_D@T_C=25^\circ C$	Continuous Drain Current, V_{GS} @ -10V	-25	A
$I_D@T_C=100^\circ C$	Continuous Drain Current, V_{GS} @ -10V	-16	A
I_{DM}	Pulsed Drain Current ¹	-97	A
EAS	Single Pulse Avalanche Energy ²	400	mJ
I_{AS}	Avalanche Current	-28	A
$P_D@T_C=25^\circ C$	Total Power Dissipation	60	W
$P_D@T_C=100^\circ C$	Total Power Dissipation	25	W
T_{STG}	Storage Temperature Range	-55 to 150	$^\circ C$
T_J	Operating Junction Temperature Range	-55 to 150	$^\circ C$

Thermal Data

Symbol	Parameter	Typ.	Max.	Unit
$R_{\theta JC}$	Thermal Resistance Junction-Case	---	2.1	$^\circ C/W$



P-Ch 100V Fast Switching MOSFETs

Electrical Characteristics (T_J=25 °C, unless otherwise noted)

Symbol	Parameter	Conditions	Min.	Typ.	Max.	Unit
BV _{DSS}	Drain-Source Breakdown Voltage	V _{GS} =0V, I _D =-250uA	-100	---	---	V
R _{DS(ON)}	Static Drain-Source On-Resistance	V _{GS} =-10V, I _D =-15A	---	40	50	mΩ
		V _{GS} =-4.5V, I _D =-10A	---	42	56	
V _{GS(th)}	Gate Threshold Voltage	V _{GS} =V _{DS} , I _D =-250uA	-1.2	-1.7	-2.5	V
I _{DSS}	Drain-Source Leakage Current	V _{DS} =-100V, V _{GS} =0V, T _J =25°C	---	---	-1	uA
		V _{DS} =-100V, V _{GS} =0V, T _J =125°C	---	---	-100	uA
I _{GSS}	Gate-Source Leakage Current	V _{GS} =±20V, V _{DS} =0V	---	---	±100	nA
g _{fs}	Forward Transconductance	V _{DS} =-5V, I _D =-15A	---	35	---	S
Q _g	Total Gate Charge	V _{DS} =-50V, V _{GS} =-10V, I _D =-15A	---	150	---	nC
Q _{gs}	Gate-Source Charge		---	18	---	
Q _{gd}	Gate-Drain Charge		---	30	---	
T _{d(on)}	Turn-On Delay Time	V _{DD} =-50V, V _{GS} =-10V, R _G =3Ω, R _L =3.3Ω	---	15	---	ns
T _r	Rise Time		---	60	---	
T _{d(off)}	Turn-Off Delay Time		---	38	---	
T _f	Fall Time		---	50	---	
C _{iss}	Input Capacitance	V _{DS} =-50V, V _{GS} =0V, f=1MHz	---	8476	---	pF
C _{oss}	Output Capacitance		---	155	---	
C _{rss}	Reverse Transfer Capacitance		---	148	---	

Diode Characteristics

Symbol	Parameter	Conditions	Min.	Typ.	Max.	Unit
I _S	Continuous Source Current	V _G =V _D =0V, Force Current	---	---	-25	A
V _{SD}	Diode Forward Voltage ³	V _{GS} =0V, I _S =-15A, T _J =25°C	---	---	1.2	V
t _{rr}	Reverse Recovery Time	I _F =-15A, di/dt=-100A/μs,	---	70	---	nS
Q _{rr}	Reverse Recovery Charge	T _J =25°C	---	125	---	nC

Note :

1.Repetitive Rating: Pulse width limited by maximum junction temperature.

2.EAS condition: T_J=25°C,V_{DD}=-60V,V_G=10V, R_G=25Ω, L=0.5mH.

3.Notes 3.Repetitive Rating: Pulse width limited by maximum junction temperature.



Typical Characteristics

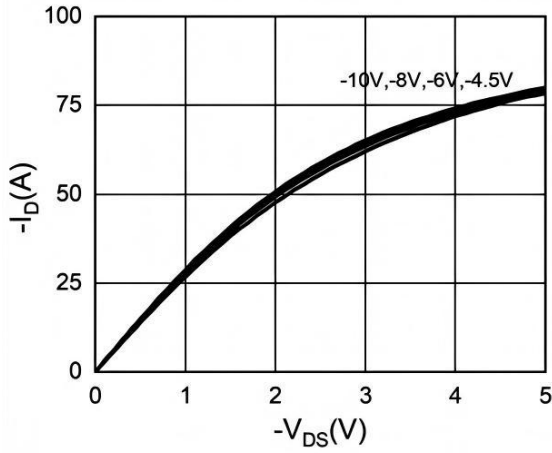

Figure 1. Output Characteristics

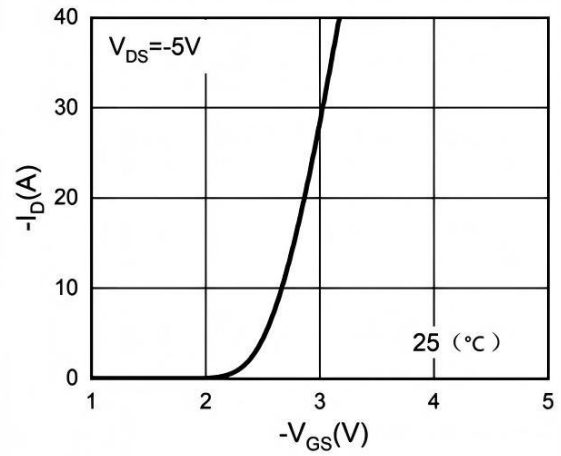

Figure 2. Transfer Characteristics

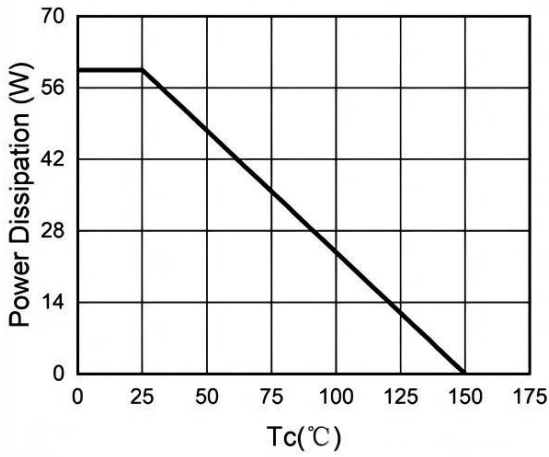

Figure 3. Power Dissipation

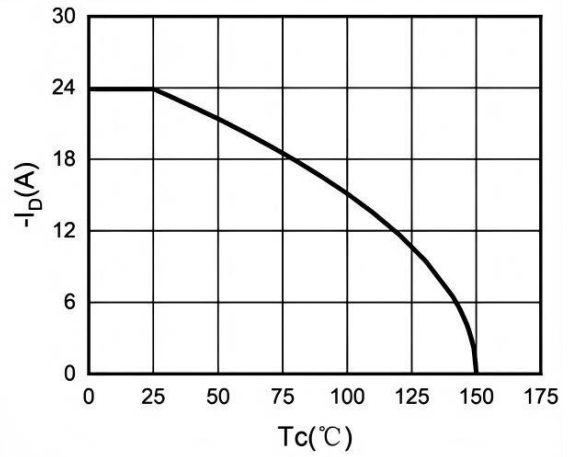

Figure 4. Drain Current

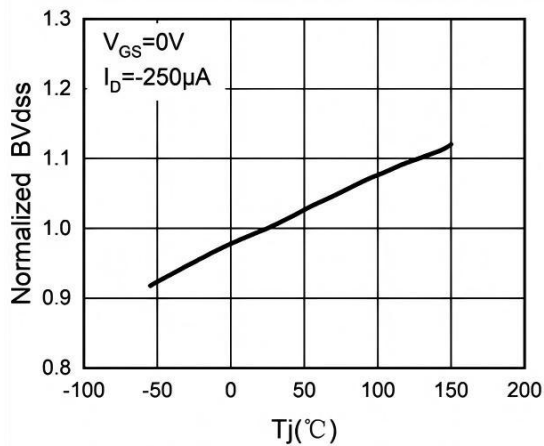

Figure 5. BV_{DS} vs Junction Temperature

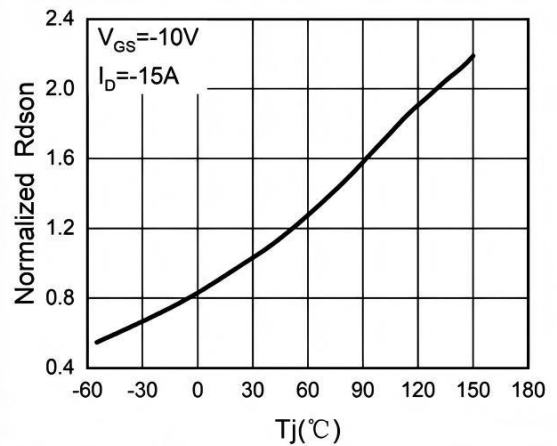

Figure 6. $R_{DS(ON)}$ vs Junction Temperature



P-Ch 100V Fast Switching MOSFETs

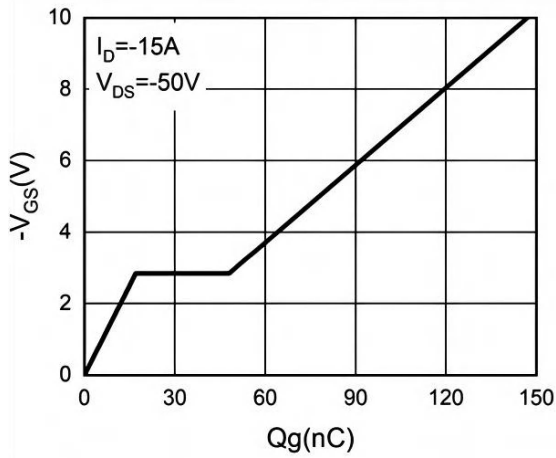

Figure 7. Gate Charge Waveforms

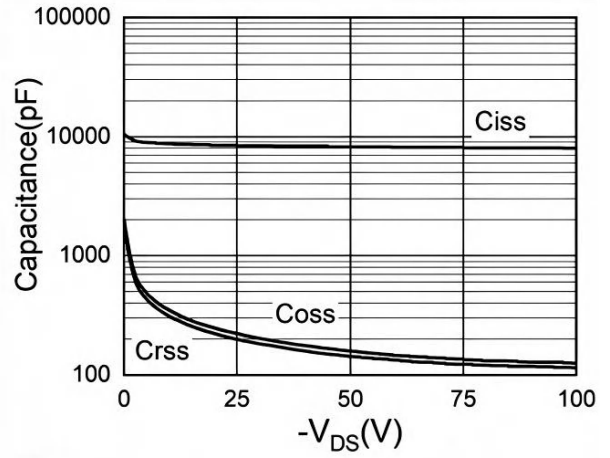

Figure 8. Capacitance

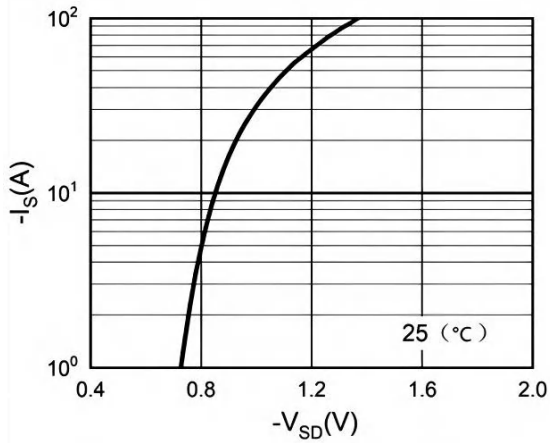

Figure 9. Body-Diode Characteristics

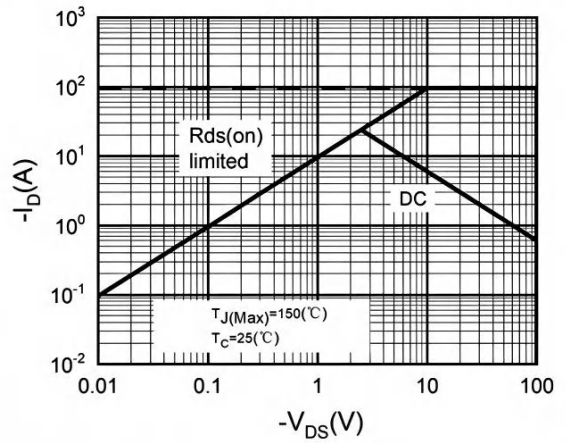

Figure 10. Maximum Safe Operating Area



Ordering Information

Part Number	Package code	Packaging
HSU0117	TO-252	3000/Tape&Reel

TO252 Package Outline

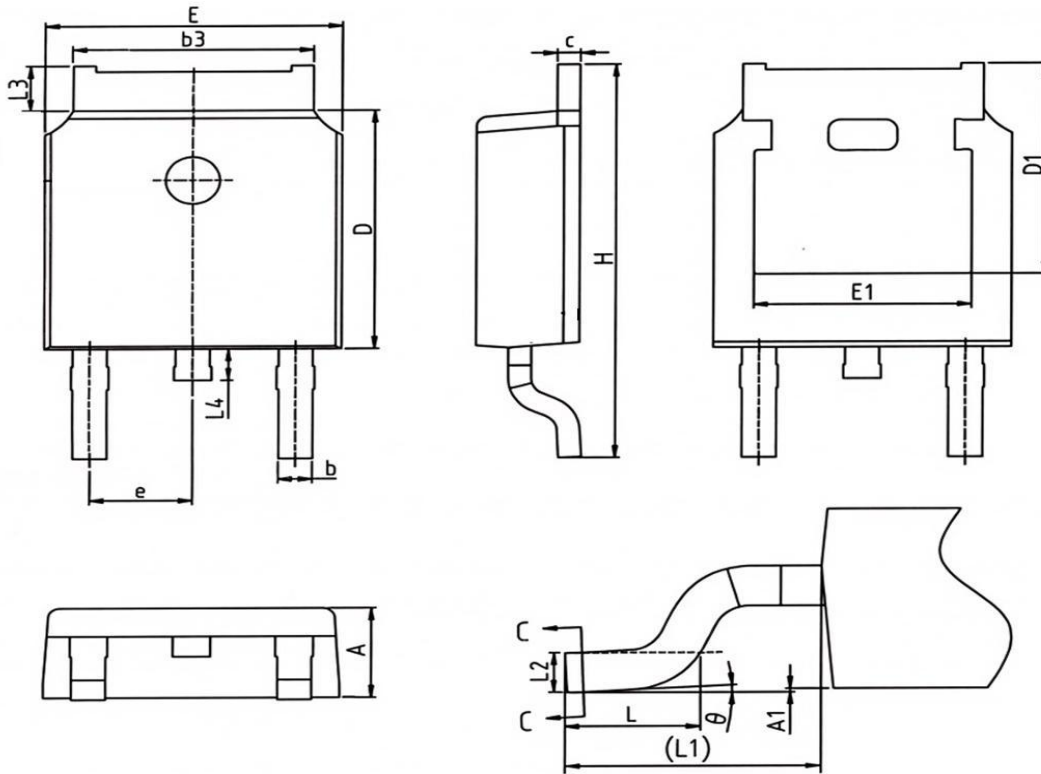

SYMBOLS	MILLIMETERS		INCHES	
	MIN	MAX	MIN	MAX
A	2.18	2.40	0.086	0.095
A1	-	0.2	-	0.008
b	0.68	0.9	0.026	0.036
b3	4.95	5.46	0.194	0.215
C	0.43	0.89	0.017	0.035
D	5.97	6.22	0.235	0.245
D1	5.300REF		0.209REF	
E	6.35	6.73	0.250	0.265
E1	4.32	---	0.170	-
e	2.286BSC		0.09BSC	
H	9.4	10.5	0.370	0.413
L	1.38	1.78	0.054	0.070
L1	2.90REF		0.114REF	
L2	0.51BSC		0.020BSC	
L3	0.88	1.28	0.034	0.050
L4	0.5	1	0.019	0.039
theta	0°	8°	0°	8°



HSU0117 Marking:

