

修 订 REV NO	标 记 MARK	修 改 描 要 REVISION DESCRIPTION	签 名 SIGNATURE	日 期 DATE
		NEW DRG		2016-03-12

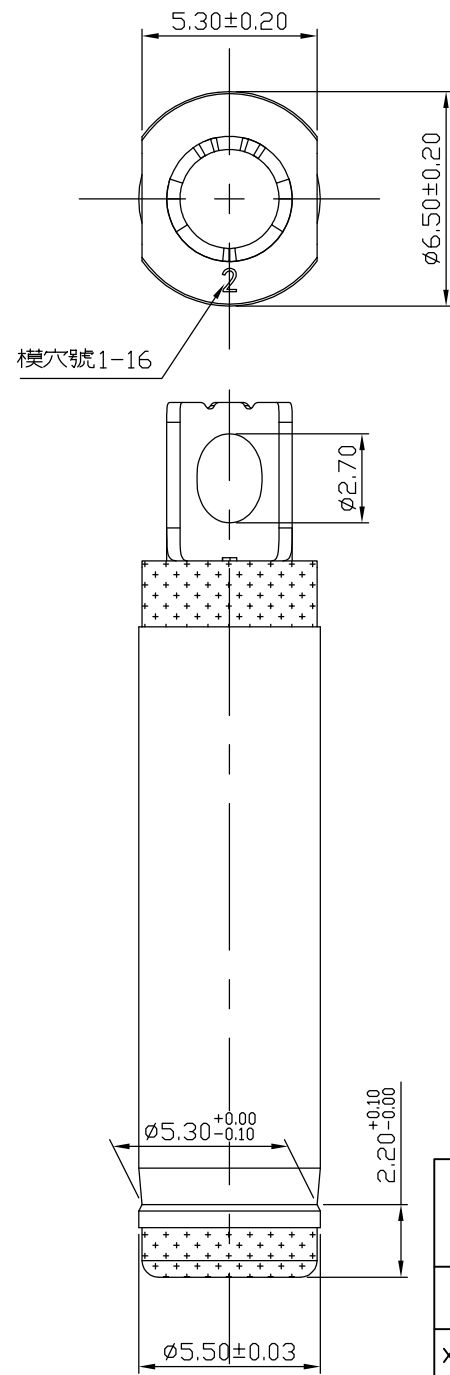

- SPECIFICATIONS:
1. Dielectric Strength: 550V DC/1 minute.
 2. Insulation resistance: 100M Ohms MIN. (AT 500V DC).
 3. Contact Resistance: 10m Ohms Max. INITIAL (pin+spring-) 20m Ohms Max. LIFE TEST AFTER (pin+spring-)
 4. HALOGEN FREE PRODUCT IDENTIFICATION LABEL ON PACKAGING
 5. FOR HAND SOLDERING LEAD-FREE PROCESS.
 6. CURRENT RATING: 20V/20A

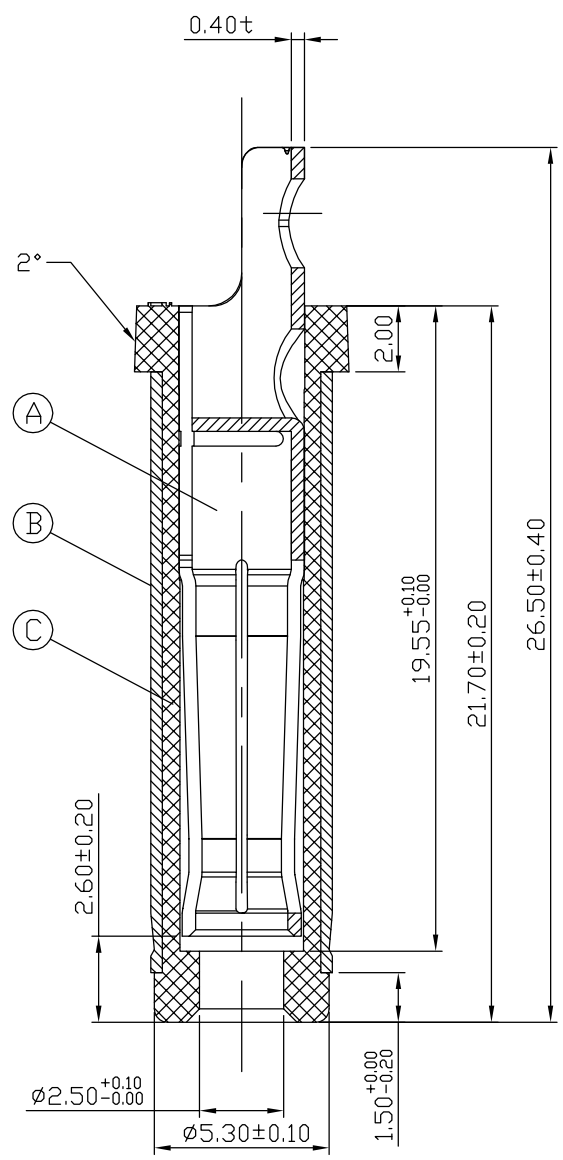

ITEM	DESCRIPTION	MATERIAL	TREATMENT	Q'TY
C	INSULATOR	PBT+30%GF 94V-0	COLOR:BLACK	1
B	SLEEVE	BRASS C3604 T0.35	NICKEL (60μ" MIN)	1
A	□ TYPE TERMINAL	C18400 T0.4	GOLD FLASH (0.7-1.5 μ")	1

深圳市华德共创科技有限公司
Shenzhen Huade co-create Technology Co., LTD

电话: 0755-27111216 传真: 0755-29940187

-TOLERANCES-
UNLESS OTHERWISE SPECIFIED
公差参数表

X.X	±0.30	X.X*	±3°	APPD: 核准:	TITLE: 产品名称: DC电源插头 5.5X2.5			
X.XX	±0.20	X.XX*	±2°	CHECK: 校对: 王建业	PART NO: 产品编号: DP550250-0188-6H			
X.XXX	±0.10	X.XXX*	±1°	DRAW: 绘图: 黄艳兰	DATE	SCALE	UNIT	CODE NUMBER
					2016-03-12	1:1	mm	A001