

RECOMMEND P.C.B LAYOUT
TOLERANCE:±0.05(TOP VIEW)

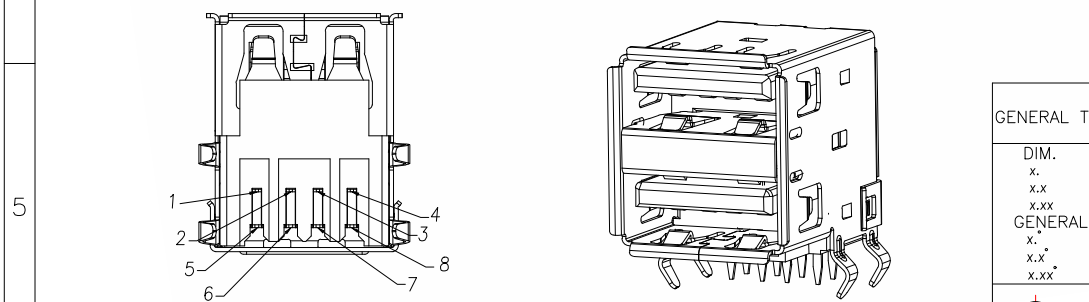
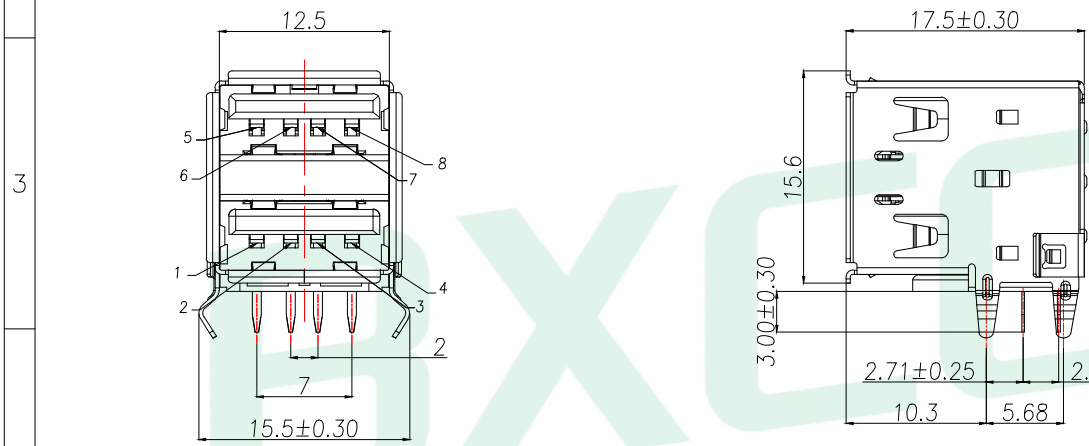

REV.	DESCRIPTION	ECN NO.	NAME	DATE

- NOTES:
- MATERIAL:
 - Housing:thermoplastic plastics
 - terminals:Copper Alloy
Gold plated in contact area:
Tin plated in termination
Nickel Plated overall
 - Shell:Steel&Copper Alloy
Nickel Plated overall
 - ELECTRICAL CHARACTERISTICS:
 - Rating Current :1.5 Ampere
 - Rating Voltage :30 V Max
 - Contact Resistance:30 Milli ohms
 - Insulation Resistance:1000 Mega ohms Min.
 - MECHANICAL CHARACTERISTICS:
 - Connector Mating force:35N MAX(3.57KgF)
 - Connector Unmating force:10N min(1.02KgF)
 - Durability:1500Cycles.
 - ENVIRONMENT CHARACTERISTICS:
 - Operating temperature:0°C to +50°C
 - Storage temperature:-20°C to +60°C

Contact Number	Signal Name
1	VBUS
2	D-
3	D+
4	GND
5	VBUS
6	D-
7	D+
8	GND

GENERAL TOLERANCE	DONGGUAN BAOXUN PRECISION TECHNOLOGY CO., LTD	
DIM. x. x.x x.xx GENERAL ANGLE: x. x.x' x.xx'	TOL. ±0.30 ±0.25 ±0.15 ±5.0° ±1.0°	
TITLE: USB AF 90度双层半包脚宽15.5弯脚	DWG. NO.: USB2.0-AF-SS-17.6	CHECKED: MAX
PART NO.: USB2.0-AF-SS-17.6	DRAWN: ELLA	
UNIT: mm	SCALE: none	SHEET: 1 of 1
DWG. SIZE: A4	LAYER: bxconn	APPROVED: WILL

