

FX25 Series

0.4mm Pitch, Small & Floating, Board-to-Board Connector

FunctionMAX™



P= 0.4mm



Floating



Compact



Nov. 1. 2025 Copyright 2025 HIROSE ELECTRIC CO., LTD. All Rights Reserved.



Features

1. 0.4mm Pitch, Compact, High Pin Count Connector

The FX25 Series contributes to space-saving in board design. Compared to Hirose's existing products with 0.5mm pitch, mounting area is reduced by approximately 40%. Furthermore, when compared to other manufacturer's products with the same 0.4mm pitch, FX25 has one of the smallest mounting areas and product volume.

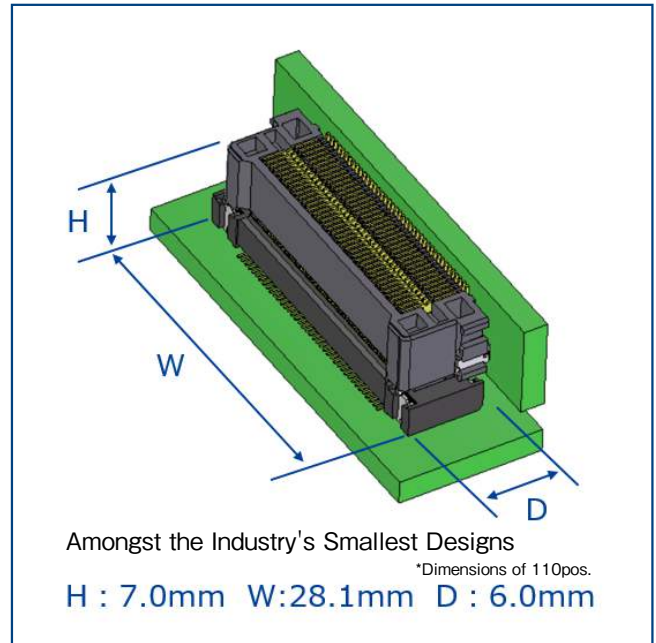

2. Connection Type : Right Angle Connection

Header Side : Straight Type
 Receptacle Side : Right Angle Type

3. Floating Amount : $\pm 0.45\text{mm}$ in the X and Y directions

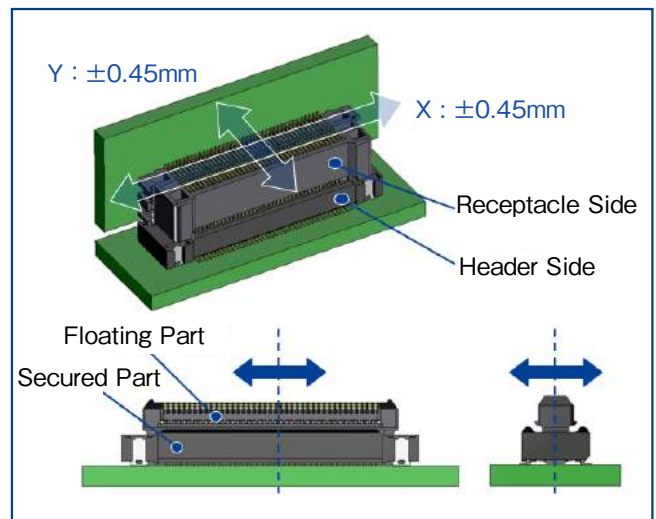

Floating Design

4. High Speed Transmission : 2.5Gbps

5. Current Capacity : 0.4A/pin

Contact uses a highly conductive material and can conduct 0.4A/pin.

6. Excellent Mating Operation Due to Wide Self-Alignment Guide

The self-alignment range of 0.75mm in both the X and Y direction contributes to assembly automation.

7. Effective Fitting Length : 1mm for High Contact Reliability Design

8. Pick & Place Mounting

This product has a flat surface for Pick & Place mounting

9. Can Inspect Soldered Area from the Top of the Connector

Application

The FX25 Series can be used in a wide range of consumer, medical, industrial and other products that require space-saving PCB design.

Product Specifications

Rated Current	0.4A	Operating Temperature (Note 1)	-55 to +85°C
Rated Voltage	50V AC/DC	Storage Temperature Range (Note 2)	-40 to +60°C
		Operating Humidity Range	Relative humidity : 85% Max. (Without Condensation)
		Storage Humidity Range (Note 2)	

Item	Specification	Conditions
Contact Resistance	60mΩ Max.	Measured at 100mA
Insulation Resistance	50MΩ Min.	Measured at 100V DC
Withstanding Voltage	No flashover or insulation breakdown	200V AC for 1 min.
Mating Durability	Contact Resistance : 80mΩ Max.	10 times insertion and extraction
Vibration Resistance	No electrical discontinuity of 1 μs Min.	Frequency 10 to 55 Hz, single amplitude 0.75 mm, 1 cycle 5 min, 3 axial 10 cycles each
Shock Resistance	No electrical discontinuity of 1 μs Min.	Acceleration 490m/s ² , Duration 11ms, 3 sine half-waves in both directions 3 times each
Moisture Resistance	Contact Resistance : 80mΩ Max. Insulation Resistance : 50MΩ Min.	Left for 96 hours at 40°C and 90 to 95% humidity
Temperature Cycle	Contact Resistance : 80mΩ Max. Insulation Resistance : 50MΩ Min.	Temperature : -55 → + 85°C Time : 30 → 30min., 5 cycles

Note 1 : Includes the temperature rise due to current flow.

Note 2 : "Storage" here refers to the long-term storage condition of unused products before the board is mounted.

The operating temperature and humidity range is applied when the circuit board is not energized after mounting, or when it is temporarily stored during transportation.

Material / Finish

Component		Material	Color / Finish	Remarks
Insulator	Header	LCP, Polyamide Resin	Black	UL94V-0
	Receptacle	LCP	Black	UL94V-0
Contact		Copper Alloy	Contact : Gold Plated (Nickel Underplating) Mounting : Gold Plated (Nickel Underplating)	-
Retention Tab		Brass	Tin Plating (Nickel Underplating)	-

Product Number Structure

Refer to the chart below when determining the product specifications from the product number.
Please select from the product numbers listed in this catalog when placing orders.

Header / Receptacle

FX25 - 110 P - 0.4 SV

① ② ③ ④ ⑤

① Series Name	FX25	④ Contact Pitch	0.4mm
② No. of Pos.	Mass Production : 80, 110pos. Under Planning : 40, 60, 100, 120pos.	⑤ Product Type	SV : Straight Type SH : Right Angle Type
③ Connector Type	P : Header S : Receptacle		

High Speed Transmission Characteristics

1. Pin Assignment

The following pin arrangement is recommended to match the 100Ω differential impedance and reduce crosstalk.



Header Side

Receptacle Side (Right Angle)



Outer side

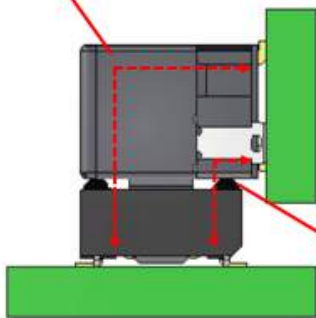

Inner side

Receptacle Side

Header Side

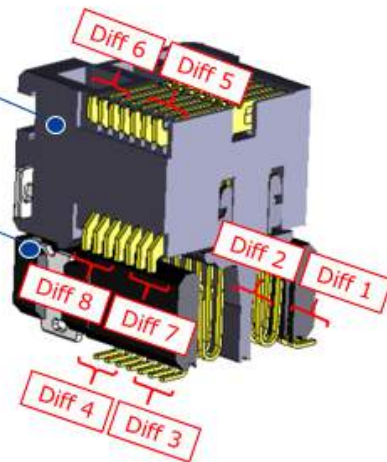

Note : Since the receptacle is a right angle type, the transmission characteristics of the inner side and outer side differ.

2. Differential Impedance 300ps Rise Time (20 to 80%)

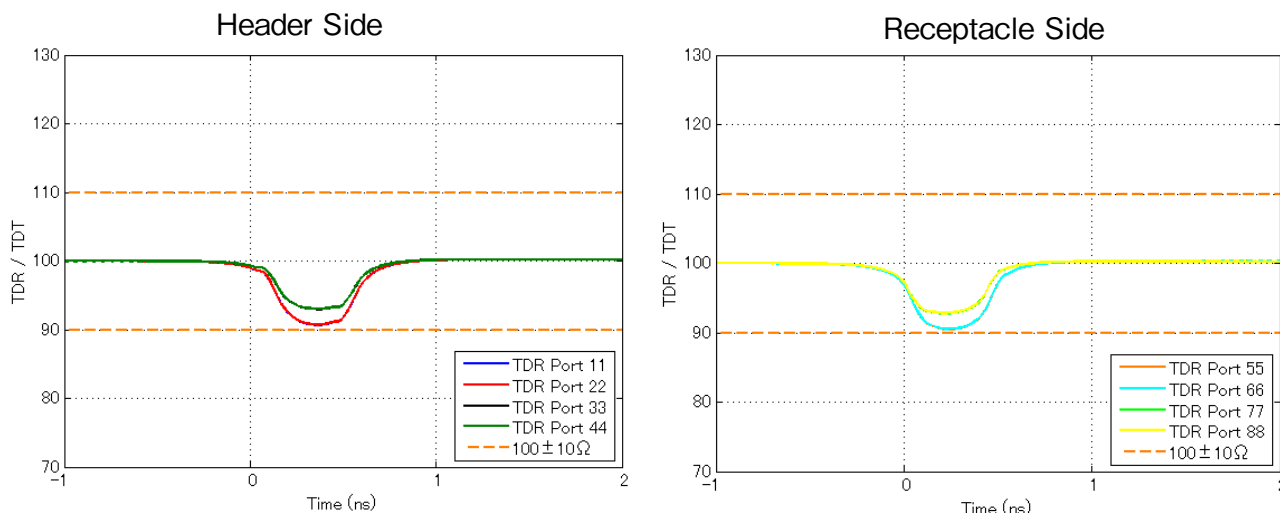

At a rise time of 300ps (20 to 80%), $100 \pm 10 \Omega$ is satisfied.

3. Insertion Loss

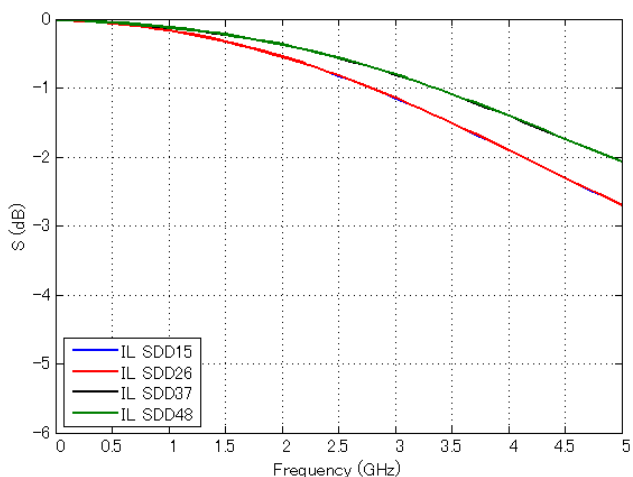

4. Return Loss

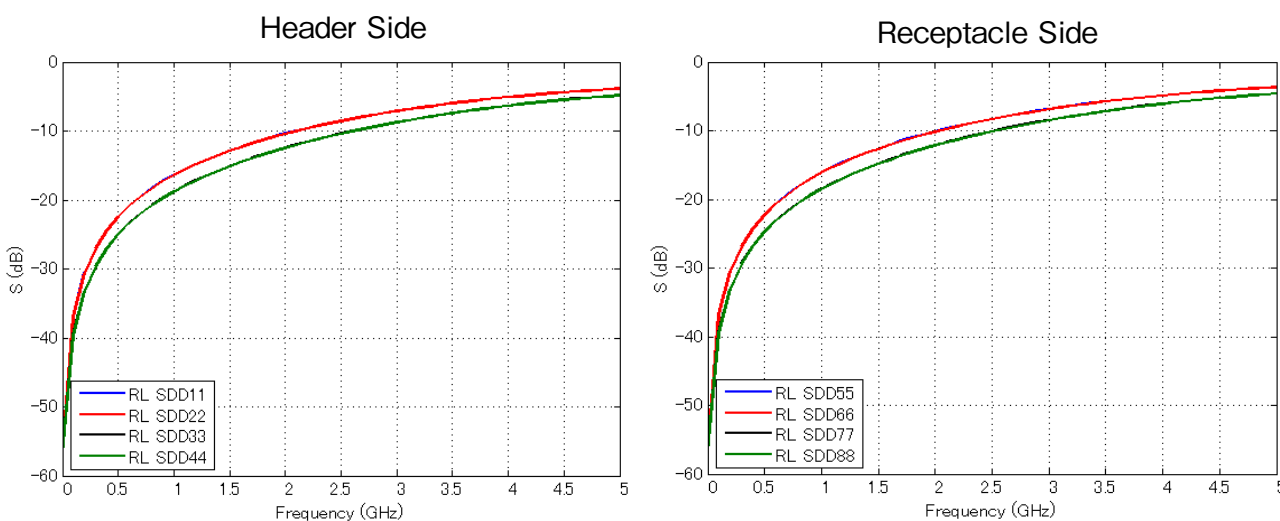

Excellent insertion loss and return loss up to 5GHz. If you have questions about the various transmission standards, please contact a Hirose representative.

Straight Header

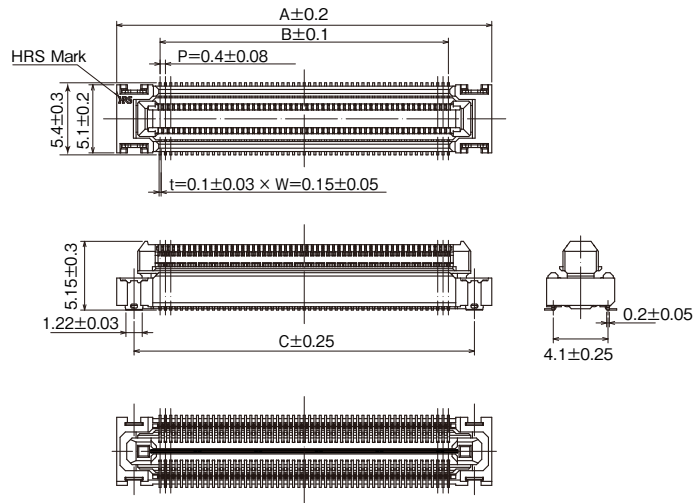
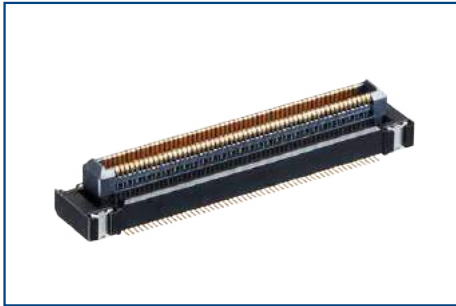

Recommended PCB Layout

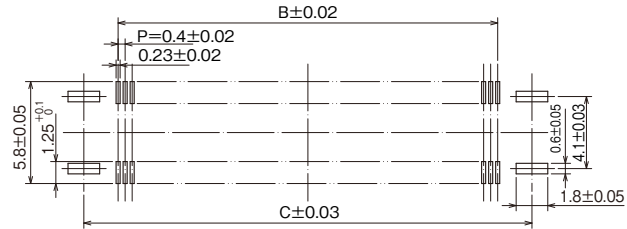

Unit : mm

Part No.	HRS No.	No. of Pos.	A	B	C	Purchase Unit
FX25-40P-0.4SV	Under Planning (Note 1)	40	14.1	7.6	11.5	-
FX25-60P-0.4SV	Under Planning (Note 1)	60	18.1	11.6	15.5	
FX25-80P-0.4SV	CL0575-4002-0-00	80	22.1	15.6	19.5	1,000pcs per reel
FX25-100P-0.4SV	Under Planning (Note 1)	100	26.1	19.6	23.5	-
FX25-110P-0.4SV	CL0575-4001-0-00	110	28.1	21.6	25.5	1,000pcs per reel
FX25-120P-0.4SV	Under Planning (Note 1)	120	30.1	23.6	27.5	-

Note 1 : Pin counts without HRS No. are currently being planned for development. Please contact a Hirose representative regarding questions on pin count variation development.

Note 2 : The header side of this product does not have polarity. It can be mated with the receptacle in any orientation.

Right Angle Receptacle

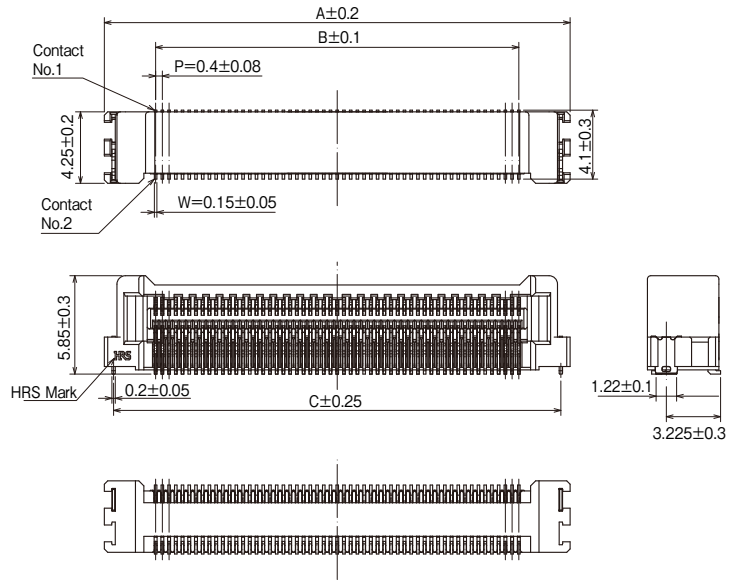
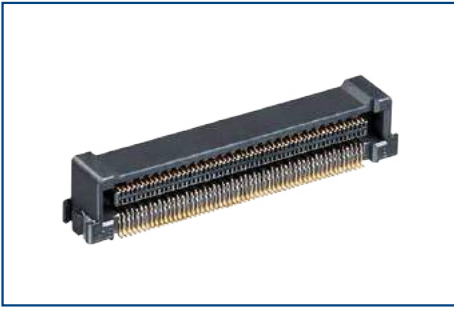

Recommended PCB Layout

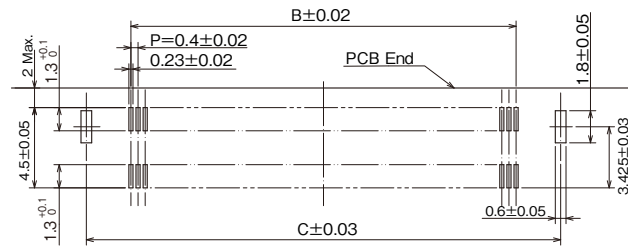

Unit : mm

Part No.	HRS No.	No. of Pos.	A	B	C	Purchase Unit
FX25-40S-0.4SH	Under Planning (Note)	40	13.7	7.6	12.6	-
FX25-60S-0.4SH	Under Planning (Note)	60	17.7	11.6	16.6	
FX25-80S-0.4SH	CL0575-4102-0-00	80	21.7	15.6	20.6	1,000psc per reel
FX25-100S-0.4SH	Under Planning (Note)	100	25.7	19.6	24.6	-
FX25-110S-0.4SH	CL0575-4101-0-00	110	27.7	21.6	26.6	1,000psc per reel
FX25-120S-0.4SH	Under Planning (Note)	120	29.7	23.6	28.6	-

Note : Pin counts without HRS No. are currently being planned for development. Please contact a Hirose representative regarding questions on pin count variation development.

Packaging Specifications

Header (FX25-##P-0.4SV)

Embossed Carrier Tape Dimensions (No scale)

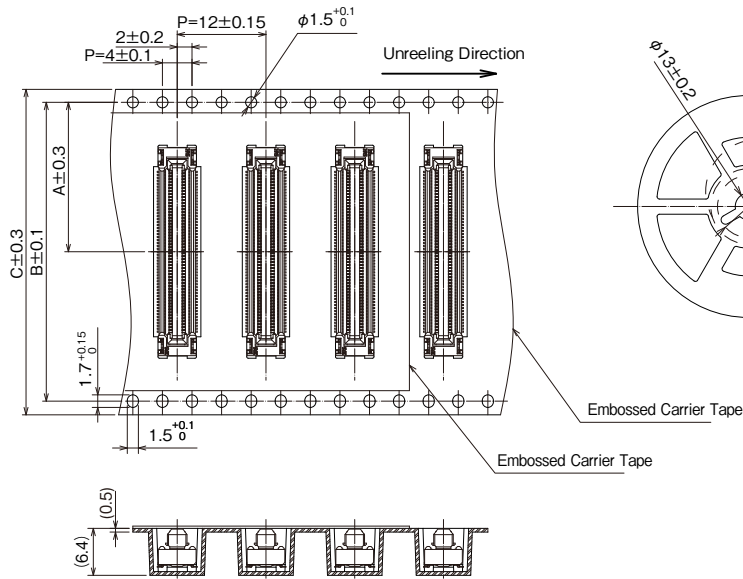

Reel Dimensions (No scale)

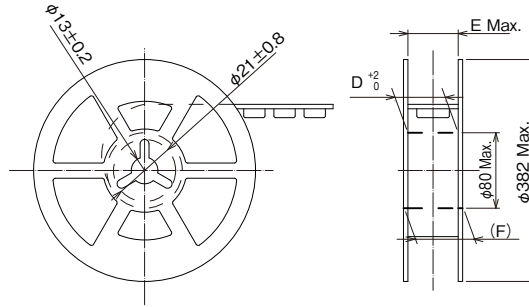

Unit : mm

Part No.	HRS No.	A	B	C	D	E	F
FX25-40P-0.4SV	Under Planning (Note 1)	-	-	-	-	-	-
FX25-60P-0.4SV	Under Planning (Note 1)	-	-	-	-	-	-
FX25-80P-0.4SV	CL0575-4002-0-00	20.2	40.4	44.0	44.4	47.4	50.4
FX25-100P-0.4SV	Under Planning (Note 1)	-	-	-	-	-	-
FX25-110P-0.4SV	CL0575-4001-0-00	20.2	40.4	44.0	44.4	47.4	50.4
FX25-120P-0.4SV	Under Planning (Note 1)	-	-	-	-	-	-

Note : Pin counts without HRS No. are currently being planned for development. Please contact a Hirose representative regarding questions on pin count variation development.

Receptacle (FX25-##S-0.4SH)

Embossed Carrier Tape Dimensions (No scale)

Reel Dimensions (No scale)

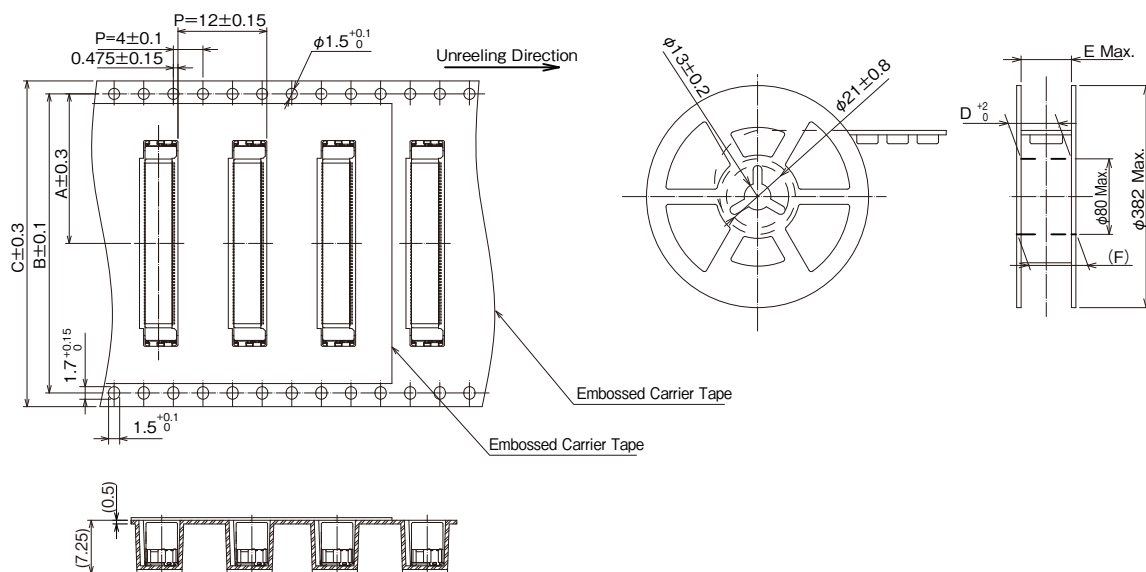

Unit : mm

Part No.	HRS No.	A	B	C	D	E	F
FX25-40S-0.4SH	Under Planning (Note)	-	-	-	-	-	-
FX25-60S-0.4SH	Under Planning (Note)	-	-	-	-	-	-
FX25-80S-0.4SH	CL0575-4102-0-00	20.2	40.4	44.0	44.4	47.4	50.4
FX25-100S-0.4SH	Under Planning (Note)	-	-	-	-	-	-
FX25-110S-0.4SH	CL0575-4101-0-00	20.2	40.4	44.0	44.4	47.4	50.4
FX25-120S-0.4SH	Under Planning (Note)	-	-	-	-	-	-

Note : Pin counts without HRS No. are currently being planned for development. Please contact a Hirose representative regarding questions on pin count variation development.

Recommended Temperature Profile

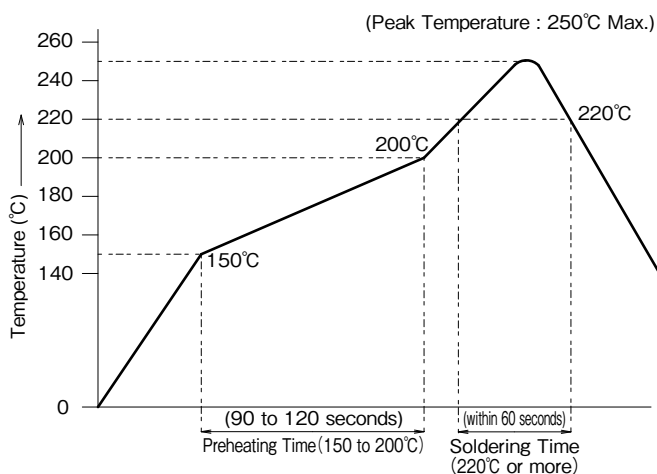

< Applicable Conditions >

Test PCB Dimensions : 110 × 60 × 1.6mm
 Material : Glass epoxy
 Solder Composition : Sn-3Ag-0.5Cu
 Flux Content : 11wt%
 Metal Mask Thickness : 0.12mm, 0.15mm
 Number of Reflow Times : 2 times Max.

This temperature profile is for the above conditions.
 The temperature profile may vary depending on the type of cream solder, the manufacturer, the board size and other conditions such as mounting materials. Please check the mounting status before use.

Cleaning Conditions

Organic Solvent Cleaning

Solvent	Cleaning at Normal Temperature	Heated Cleaning
IPA (Isopropyl Alcohol)	OK	OK

Water-Based Cleaning

When using water-based cleaning agents (e.g., terpene, and alkali saponifiers), select the cleaning agent based on the documentation issued by the various manufacturers, which describes its effects on metals and resins. Do not to leave moisture on the connectors.

Cleaning Precautions

Residual flux or cleaning agents on the connectors from cleaning with organic solvents or water-based cleaners may cause deterioration of the electrical performance. It is important to check that a thorough washing has been performed.

Precautions During Use

Specified Dimensions Between PCBs

Please confirm the Drawing and use within the specified dimensions.

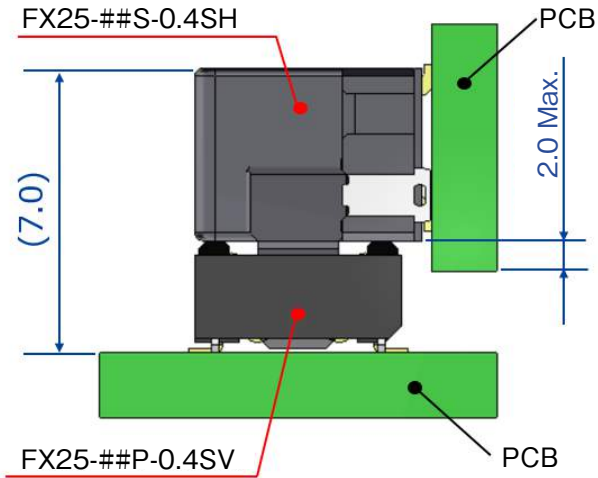

Securing PCBs

Using only connectors is not recommended. If the board is supported only by the connector, an excessive load may be applied to the connector which may result in damage or contact failure. Take measures to secure the board other than using the connector.

Mating Precautions

The self-alignment range is $\pm 0.75\text{mm}$ in the X and Y directions.

While following the guide, insert the connector straight in without applying excessive load during mating.

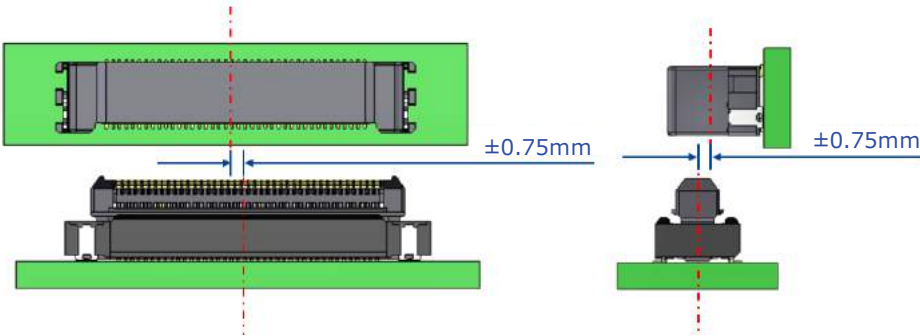

Self-Alignment Range :

X Axis Direction (Longitudinal Direction) : $\pm 0.75\text{mm}$

Y Axis Direction (Lateral Direction) : $\pm 0.75\text{mm}$

Mating Precautions

It is recommended to operate the connector straight without tilting the connector. If it is not possible to operate the connector straight due to the layout of the board or the panel design, refrain from bending the connector as much as possible during mating while making sure not to apply excessive force. When mating is completed, align the connectors so they are connected straight.

Misalignment Allowance in the Mated Condition

Since this connector has a floating design, the maximum allowable PCB misalignment amount is $\pm 0.45\text{mm}$ in the X and Y directions when mated. However, it is not suitable for misalignment absorption when the misalignment amount constantly changes due to vibration, etc. Be sure to secure the PCBs after mating. The floating operation can be repeated 10 times max. based on the connector mating durability (insertion/extraction times).

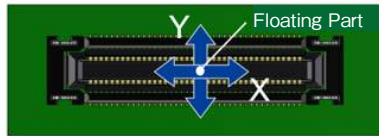

Misalignment Tolerance Land : $\pm 0.45\text{mm}$

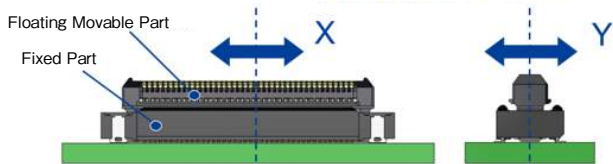

[FX25 Series Header Side : Floating Design]

Floating Movable Amount : XY Axis $\pm 0.45\text{mm}$

While Taking into Consideration

Specifications mentioned in this catalog are reference values.

When considering to order or use this product, please confirm the Drawing and Product Specifications sheets.

Use an appropriate cable when using the connector in combination with cables.

If considering usage of a non-specified cable, please contact your sales representative.

If assembly process is done by jigs & tools which are not identified by Hirose, assurance will not be given.

If considering usage for below mentioned applications, please contact your sales representative.

In cases where the application will demand a high level of reliability, such as automotive, medical instruments, public infrastructure, aerospace/ defense etc. Hirose must review before assurance of reliability can be given.