



产品承认书

SPECIFICATION FOR APPROVAL

客户名称:
CUSTOMER

我司料号:
OUR PART NO.

XRSQ1515-15mH-V-1013

我司品名:
OUR PART NAME

SQ扁平线电感

送样日期:
DATE SAMPLES

数量: 0PCS
QUANTITY

制造确认 MANUFACTURER APPROVE

拟制 DRAWN	审核 CHECKED	确认 APPROVED

客户确认 CUSTOMER APPROVE

客户名称 CUSTOMER NAME:

客户料号 CUSTOMER P/N:

规格型号 DESCRIPTION: SQ1515 立式 15mH 10*13 脚距 0.15t*1.5线

检查结果: 合格 不合格

签名及盖章:

INSPECT RESULT ACCEPT REJECT

SIGNATURE AND STAMP

说明 REMARK:

如对本承认书内容有异议请提出或标记发送至我司, 本承认书在未收到异议回复时于本承认书提供一周后生效。

东莞市祥如电子有限公司

地址: 广东省东莞市塘厦镇莲湖第一工业区南二横路36号B栋

电话: 0769-86346548 传真: 0769-86346358

邮箱: dgxiangru@126.com



东莞市祥如电子有限公司

SPECIFICATION FOR APPROVAL

CUSTOMER _____
CUSTOMER 'S PART NO _____ VER _____ A
DESCRIPTION SQ1515-15mH 立式 10x13 脚距 OUR DRAWING NO XRSQ1515-15mH-V-1013

A REVISION HISTORY

DATE OF	REVISED PROJECT	EDITION	NOTE
2019/07/22	NEEW VERSION	A	
2024/07/19	REVISION		

PPROVED BY	CHECKED BY	PREPARED BY	UNIT	mm
李振雄	唐文	谢诗珍	DATE	2024/07/19
			REV NO.	A

东莞市祥如电子有限公司

SPECIFICATION FOR APPROVAL

CUSTOMER _____

CUSTOMER 'S PART NO _____

VER _____

A

DESCRIPTION _____

SQ1515-15mH 立式 10x13 脚距 _____

OUR DRAWING NO _____

XRSQ1515-15mH-V-1013

1. APPEARANCE & DIMENSION (UNIT: mm):

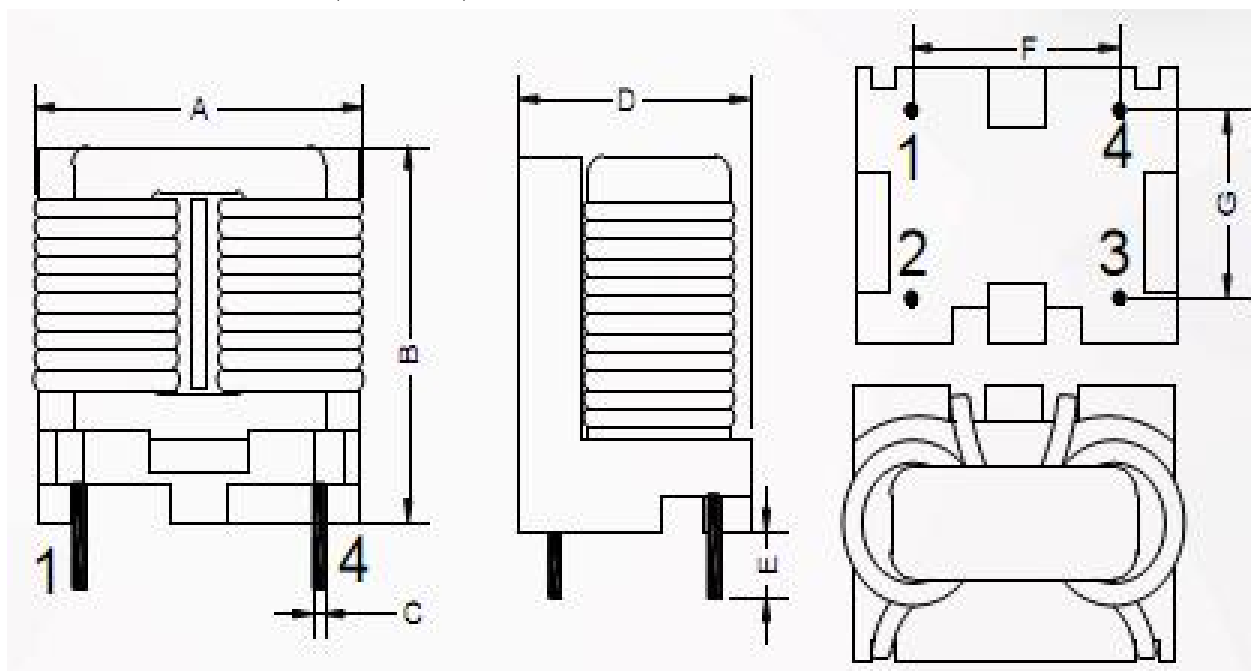

A	B	C	D	E	F	G
21.5MAX	20.5MAX	0.6±0.1	15.5MAX	3.5±0.5	12.8±0.5	10±0.5

NOTE:

1. 产品共模绕制。
2. 产品需含浸凡立水固定。
3. 焊点不可高于底座支点。

Page3/7

PPROVED BY	CHECKED BY	PREPARED BY	UNIT	mm
李振雄	唐文	谢诗珍	DATE	2024/07/19
			REV NO.	A

东莞市祥如电子有限公司

SPECIFICATION FOR APPROVAL

CUSTOMER _____

CUSTOMER 'S PART NO _____

DESCRIPTION _____

SQ1515-15mH 立式 10x13 脚距

VER _____

A

OUR DRAWING NO _____

XRSQ1515-15mH-V-1013

2. SCHEMATIC:

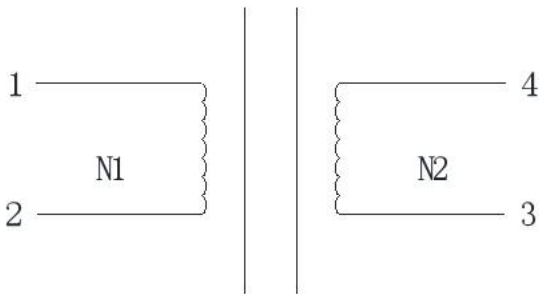

3. WINDING SEQUENCE:

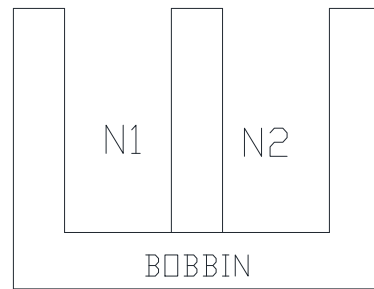

4. WINDING TABLE

ORDER	WIRE SIZE	START	END	TURNS	LAYER	INSULATION	
N1	0.15t×1.5mm UEWH 扁平线	1	2	48TS (REF)	CLOSE		
N2	0.15t×1.5mm UEWH 扁平线	4	3	48TS (REF)	CLOSE		

PPROVED BY	CHECKED BY	PREPARED BY	UNIT	mm
李振雄	唐文	谢诗珍	DATE	2024/07/19
			REV NO.	A



东莞市祥如电子有限公司

SPECIFICATION FOR APPROVAL

CUSTOMER _____

CUSTOMER 'S PART NO _____

VER _____

A

DESCRIPTION SQ1515-15mH 立式 10x13 脚距

OUR DRAWING NO _____

XRSQ1515-15mH-V-1013

5. ELECTRICAL CHARACTERISTICS:

TEST CONDITION:		TEMPERATURE AT: 25°C ± 5°C WORKING TEMPERATURE: -25°C/+125°C STORAGE TEMPERATURE: -25°C/+40°C HUMIDITY: AT45-80% RH	
TEST INSTRUMENT	CHENHWA/1062	CHENHWA/1062	CHENHWA/502A
ITEM	INDUCTANCE 1KHz, 0.25Vrms 25°	DIFFERENCE INDUCTANCE 1KHz, 0.25V	DC. RESISTANCE AT 25°C
TERMINAL			
1-2	15mH MIN	0.3mH Max	180m Ω MAX
3-4	15mH MIN	0.3mH Max	180m Ω MAX
TEST INSTRUMENT	E-SUN 19053	E-SUN/19053	
ITEM	HI-POT TEST AC50/60Hz, 5mA, 3sec	INSULATION RESISTANCE. DC 500V	
TERMINAL			
COIL-COIL	1500V	100M Ω MIN	
COIL-CORE	1000V	100M Ω MIN	
Idc		2.8A	

Page 5/7

APPROVED BY	CHECKED BY	PREPARED BY	UNIT	mm
李振雄	唐文	谢诗珍	DATE	2024/07/19
			REV NO.	A



东莞市祥如电子有限公司

SPECIFICATION FOR APPROVAL

CUSTOMER _____

CUSTOMER 'S PART NO _____

VER _____

A

DESCRIPTION _____

SQ1515-15mH 立式 10x13 脚距

OUR DRAWING NO _____

XRSQ1515-15mH-V-1013

6. MATERIAL LIST:

No	ITEM	MATERIAL	CLASS	UL NO.	MANUFACTURER	OPT.
1	CORE	SQ1515 12K			ACMEElectronics (Guangzhou) Co;Ltd	√
		SQ1515 12K			SHANGDONG hengrui magnet technology CO.,LTD	√
		SQ1515 12K			DongGuan City JiuXin Magnetic Material Co.,Ltd	√
		SQ1515 12K			TengZhou MingJi Magnetism Industry Co., Ltd.	√
2	BOBBIN	T375HF	150°C	E59481	CHANG CHUN PLASTICS CO LTD	√
3	WIRE	@* FIWx180	180°C	E234867	SUNTEK HOLDINGS LIMITED	√
		@* UEW180	180°C	E504985	Guangdong Lizewire Electric Technology Co Ltd	√
4	VARNISH	E962	130°C	E335405	ZHUHAI CHANGXIAN NEW MATERIALS TECHNOLOGY CO LTD	√
5	锡	无铅锡条 /Sn99.9			Dongguan City Thousand Island METAL Foil CO LTD	√

Page6/7

PPROVED BY	CHECKED BY	PREPARED BY	UNIT	mm
李振雄	唐文	谢诗珍	DATE	2024/07/19
			REV NO.	A

