

修订	标记	修改摘要	签名	日期
REV	MARK	REVISION DESCRIPTION	SIGNATURE	DATE
AO		NEW DWG		2016-03-12

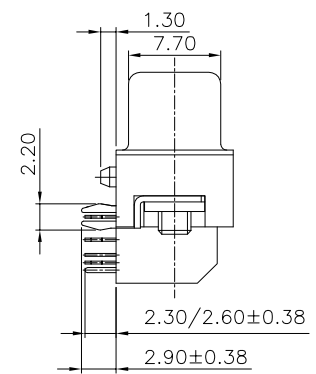

- NOTE:
- 一、 MATERIALS:
1. Housing: SEE PART NO. Color: SEE PART NO.
 2. Cover: SEE PART NO. Color: SEE PART NO.
 3. Contacts: Brass
 4. Shell: SPCC
 5. Board Lock: SPCC
 6. Rivet: Copper Alloy
 7. Screw: SPCC Or Copper Alloy
- 二、 FINISH:
1. Contacts: Gold Plated on Contact Area
Sn Plated on Solderails
Nickel Under Plated Over All
 2. Shell: Nickel Plated
 3. Board Lock: Sn Plated
 4. Rivet: Nickel Plated
 5. Screw: Nickel Plated

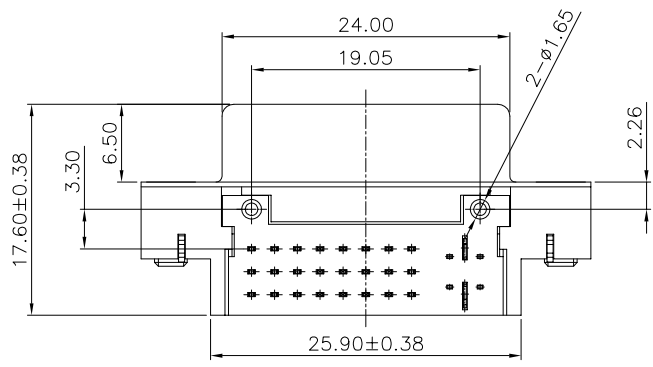
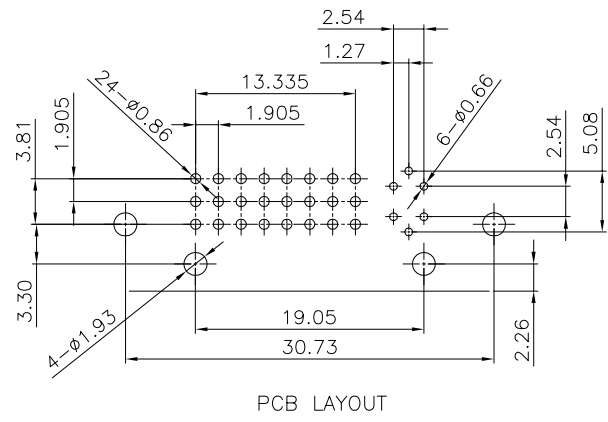
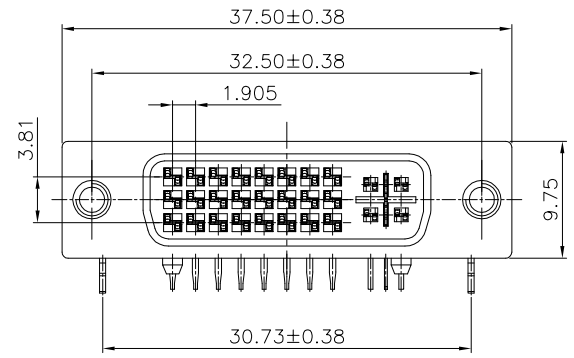

深圳市华德共创科技有限公司
Shenzhen Huade co-create Technology Co.,LTD
电话: 0755-27111216 传真: 0755-29940187

-TOLERANCES- UNLESS OTHERWISE SPECIFIED 公差参数表		TITLE: 产品名称: DVI 24+5母座无边不带螺丝	
X.X ±0.30	X.X* ±3°	APPD: 核准:	PART NO: 产品编号: DVI-HX-103DIP
X.XX ±0.20	X.XX* ±2°	CHECK: 校对: 王建业	DATE SCALE UNIT CODE NUMBER
X.XXX ±0.10	X.XXX* ±1°	DRAW: 绘图: 黄艳兰	2016-03-12 1:1 mm A001