

# CONSONANCE

## 4.5V to 32V Input Current Mode Boost DC-DC Controller

### CN5120

#### General Description:

The CN5120 is a current mode fixed-frequency PWM controller for both flyback and step-up DC-DC converters. The device operates from an input supply between 4.5V and 32V and provides to drive an external N-channel MOSFET.

The CN5120 contains all the necessary building blocks including a bandgap reference, a 330KHz oscillator, current-mode control circuitry, chip shutdown block, softstart block and gate driver, etc. Current mode control provides improved transient response and simplified loop compensation. On-chip soft start reduces the inrush current on power up. The other features include chip shutdown, over voltage protection, built-in 5V regulator and slope compensation, etc.

The CN5120 is available in 10-pin SSOP package.

#### Applications:

- TFT-LCD Bias Supplies
- XDSL Power Supplies
- Medical Equipments
- Digital Video Cameras
- Portable Devices

#### Features:

- Peak Current Mode DC-DC Boost/ Flyback Controller
- 4.5V to 32V Input Range
- 330kHz Switching Frequency
- $\pm 2\%$  Output Voltage Accuracy
- Cycle-by-Cycle Peak Inductor Current Limit
- On-Chip Slope Compensation
- Internal Soft-start
- Built-in 5V regulator
- Low Shutdown Current
- Operating Temperature Range:  
-40°C to 85°C
- Available in 10-pin SSOP package.
- Lead-free, Rohs-compliant and Halogen-free

#### Pin Assignment

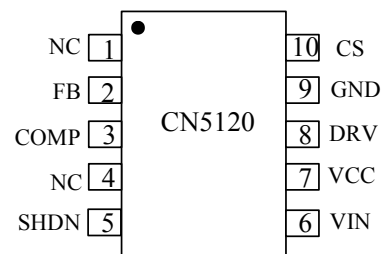

# CONSONANCE

## Typical Application Circuit

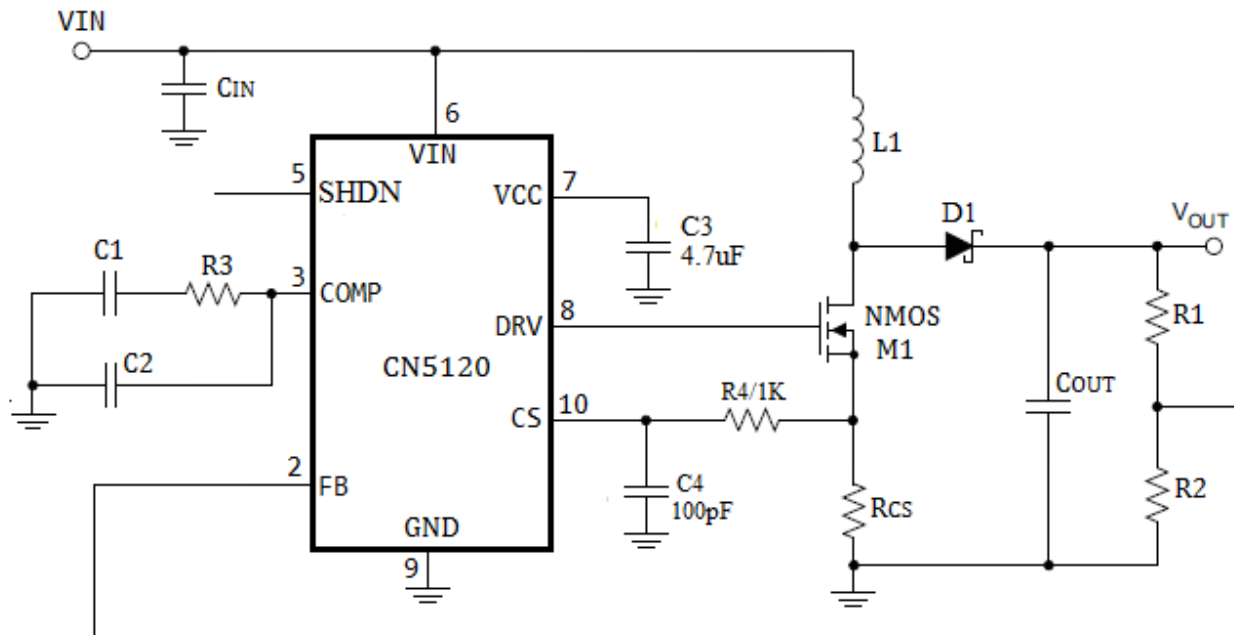

Figure 1 Typical Application Circuit

## Pin Description

No.	Name	Description
1	NC	<b>No Connection.</b>
2	FB	<b>Feedback Pin.</b> The output voltage is feedback to this pin. Generally this pin is connected to the external resistor divider to sense the output voltage.
3	COMP	<b>Compensation Pin.</b> Connect the compensation network between COMP pin and GND.
4	NC	<b>No Connection.</b>
5	SHDN	<b>Shutdown Input Pin.</b> Pulling this pin high, places the part into a shutdown mode. Shutdown mode is characterized by a very low quiescent current. In shutdown mode, all the functionality of all blocks is disabled and the on-chip 5V regulator is also shutdown. Pulling this pin low places the part into normal operation mode.
6	VIN	<b>Input Supply Voltage.</b> Positive terminal of input supply. The input voltage range is 4.5V to 32V. Connect a local bypass capacitor from this pin to GND.
7	VCC	<b>5V Regulator output.</b> A bypass capacitor of 4.7uF should be connected from this pin to GND. If the input voltage is less than 5.5V, the voltage at VCC pin may be less than 5V.
8	DRV	<b>Gate Drive Pin.</b> Gate drive for the external N-channel MOSFET. Connect this pin to the gate of external N-channel MOSFET.
9	GND	<b>Ground.</b> Negative terminal of input supply.
10	CS	<b>Inductor Current Sense Pin.</b> The inductor current is sensed at CS pin on the cycle-by-cycle basis for both the current mode control and over current protection.

# CONSONANCE

## Absolute Maximum Ratings

VIN Terminal Voltage.....	-0.3V to 36V	Maximum Junction Temperature.....	150°C
Other Terminals Voltage.....	-0.3V to 6.5V	Storage Temperature.....	-65°C to 150°C
Operating Temperature.....	-40°C to 85°C	Lead Temperature(Soldering).....	260°C
Thermal Resistance(Junction to Case) .....	200°C/W		

*Stresses beyond those listed under “Absolute Maximum Ratings” may cause permanent damage to the device. These are stress ratings only, and functional operation of the device at these or any other conditions beyond those indicated in the operational sections of the specifications is not implied. Exposure to absolute maximum rating conditions for extended periods may affect device reliability.*

## Electrical Characteristics

(VIN = 12V, TA = -40°C to +85°C, Typical values are at TA = +25°C, unless otherwise noted)

Parameters	Symbol	Test Conditions	Min	Typ	Max	Unit
Input Supply Voltage	VIN		4.5		32	V
Input Supply Current	IVIN	VFB = 1.3V, VSHDN=0V	700	810	920	µA
Shutdown Current	ISD	SHDN = 3V, VIN = 12V	3.6	5.2	6.8	µA
		SHDN = 3V, VIN = 30V	9	13	17	
Switching Frequency	fSW	Normal operation	285	330	375	KHz
Maximum Duty Cycle	DMAX			93		%
Minimum On Time	TMIN			100		ns
Soft-Start Time	TSS			9.5		ms
Over current Threshold	VCS(OC)	Measured at CS pin	170	180	190	mV
<b>FB Pin</b>						
Feedback Voltage	VFB	Normal operation	1.181	1.205	1.229	V
FB Pin Bias Current	IFB		-100	0	+100	nA
<b>SHDN Pin</b>						
Input Voltage High	VIH		2.3			V
Input Voltage Low	VIL				0.5	V
SHDN Bias Current	ISHDN		-100	0	+100	nA
<b>DRV Pin</b>						
Source Current		VDRV = 4V		0.8		A
Sink Current		VDRV = 1V		1.5		A
Fall Fime	tf	CDRV = 2nF		22		ns
Rise Time	tr	CDRV = 2nF		30		ns
<b>VCC Pin</b>						
Output Voltage	VCC	IVCC = 0.1mA to 4mA, VIN = 5.5V to 32V	4.7		5.3	V
Load Regulation		IVCC = 0.1mA to 4mA,		5		Ohm
Line Regulation		VIN = 6V to 32V, IVCC = 3mA		6		mV
PSRR	PSRR	IVCC = 3mA, fIN = 10kHz		-35		dB
Startup Time	tSTART	VCC = 0 to 4.5V, COUT = 4.7µF		5		mS

# CONSONANCE

---

## Detailed Description

The CN5120 is a current mode fixed-frequency PWM controller for both boost and flyback DC-DC converters. The device operates from an input supply between 4.5V and 32V and provides to drive an external N-channel MOSFET.

The CN5120 contains all the necessary building blocks including a bandgap reference, error amplifier, 330KHz oscillator, compensation slope generator, current-mode control circuitry, inductor over current protection circuit, chip shutdown block, softstart block and gate driver, etc.

Current mode control provides improved transient response and simplified loop compensation. A dedicated COMP pin allows the optimization of loop response. Soft start reduces the inrush current on power up.

The internal over voltage comparator monitors the output voltage, if the output voltage is higher than nominal value by 6.5%, the DRV pin will be pulled low until the output voltage falls within 1% of nominal value.

## Application Information

### Input Voltage Range

The CN5120 is intended to implement boost and flyback (isolated and nonisolated) DC-DC converters. The input voltage range is from 4.5V to 32V.

### Shutdown

The SHDN pin is active high shutdown input. Pulling this pin above 2.3V causes the CN5120 to completely shut down and enter a low current consumption state. In this state, the regulator connected to the VCC pin is turned off. Pulling SHDN pin below 0.5V brings the CN5120 back to normal operation.

### +5V Regulator

The CN5120 includes a fixed +5V output regulator that delivers up to 4mA of load current for low-power applications throughout the +5.5V to +32V input voltage range. The regulator supplies power for the internal low voltage circuitry of the controller including the gate driver.

Connect a 4.7μF bypass capacitor from VCC pin to GND.

It is not recommended to use the +5V regulator to power the external circuitry, otherwise the gate drive capability may be affected.

When SHDN pin is pulling high, the 5V regulator is also turned off.

### Setting the Output Voltage

Output voltage is set by the external resistor divider as shown in Figure 1, and is calculated by the following equation:

$$V_{OUT} = V_{ref} \times \left(1 + \frac{R1}{R2}\right)$$

Where, Vref is the internal bandgap reference, typical value is 1.205V.

The internal bandgap reference's accuracy is ±2%, the tolerance of R1 and R2 may also affect output voltage's accuracy.

In theory, the output voltage can be set more than 100V, but it is limited by the DRV pin's driving capability. Since when output voltage is high, the external N-channel MOSFET's Qg may become large and threshold voltage may become high.

### N-Channel MOSFET Gate Driver (DRV Pin)

The CN5120 offers a built-in gate driver for driving an external N-channel MOSFET. The DRV pin can source/sink currents in excess of 800mA/1500mA. The gate driver is powered by on-chip 5V regulator, so the voltage at DRV pin is 5V while output high.

### Over Voltage Protection

# CONSONANCE

---

The internal over voltage comparator monitors the output voltage, if the output voltage is higher than nominal value by 6.5%, the DRV pin will be pulled low by the over voltage protection circuit, the output voltage will not rise any more until the output voltage falls back within 1% of nominal value.

## Duty Cycle Estimation

For a boost DC-DC Converter operating in continuous conduction mode (CCM), the duty cycle is:

$$D = 1 - \frac{V_{IN}}{V_{OUT} + V_D}$$

Where,  $V_{IN}$  is the input voltage,  $V_{OUT}$  is output voltage,  $V_D$  is the forward voltage of freewheeling diode.

So the maximum duty cycle occurs when  $V_{IN}$  is minimum, namely:

$$D_{max} = 1 - \frac{V_{INmin}}{V_{OUT} + V_D}$$

The minimum duty cycle occurs at  $V_{IN}$  is maximum, namely:

$$D_{min} = 1 - \frac{V_{INmax}}{V_{OUT} + V_D}$$

## Maximum Inductor Current (Input Current)

CN5120 measures the inductor current (Input current) by sensing the voltage across the current sense resistor ( $R_{CS}$  in Figure 1) between the source of external N-channel MOSFET and GND. So the output current needs to be reflected back to the input in order to guarantee the correct voltage regulation. Based on the fact that, ideally, the output power is equal to the input power, the maximum average inductor current is:

$$I_{IN} = I_L = \frac{I_{omax}}{1 - D_{max}}$$

The internal current mode control loop will not allow the inductor peak to exceed  $0.18/R_{CS}$ . In practice, one should allow some margin for variations in the CN5120 and external component values, and a good guide for selecting the peak inductor current (Input current) is:

$$I_{INpeak} = I_{Lpeak} = 1.8 \times \frac{I_{omax}}{1 - D_{max}}$$

## Inductor Selection

An inductor should be chosen that can carry the maximum input DC current which occurs at the minimum input voltage. The peak-to-peak ripple current is set by the inductance and a good starting point is to choose a ripple current of 30% of its maximum value:

$$\Delta I_L = 30\% \times \frac{I_{omax}}{1 - D_{min}}$$

The inductor value should meet the requirement of the following equation:

$$L \geq \frac{V_{INmax} \times D_{min}}{f_{sw} \times \Delta I_L}$$

Where,  $f_{sw}$  is the switching frequency in Hz, typical value is 330KHz.

## Current Sense Resistor Selection

The CN5120 is current mode controller and use a resistor in series with the source terminal of external N-channel MOSFET to perform cycle-by-cycle inductor current sense for both the current mode control and over

# CONSONANCE

current protection. The current sense resistor is shown in Figure 1 as  $R_{CS}$ . The DRV pin will become low and turn off the external N-channel MOSFET if the voltage at the CS pin exceeds the current limit threshold voltage  $V_{CS(oc)}$  from the electrical specifications table.

So the value of  $R_{CS}$  should meet the requirement of the following equation:

$$R_{CS} \leq \frac{V_{CS(oc)}}{I_{Lpeak}} = \frac{1-D_{max}}{10 \times I_{omax}}$$

The CN5120 adopts peak current mode control to regulate the output voltage, which needs a compensation slope to prevent the device from sub-harmonic oscillation. In CN5120, the compensation slope is applied in a fixed amount. At CS pin, the compensation slope is:

$$S_e = 5.5 \times 10^4 \text{ V/S}$$

To ensure that the converter does not enter into sub-harmonic oscillation, the compensation slope  $S_e$  must be at least half of the down slope of the current sense signal at CS pin. Since the compensation slope is fixed in the CN5120, this places a constraint on the selection of the current sense resistor.

The down slope of the current sense signal at CS pin is:

$$m2 = \frac{R_{CS} \times (V_{OUT} + V_D - V_{IN})}{L}$$

Where,

- $S_e$  is the compensation slope applied to CS pin in V/S
- $m2$  is the down slope of the current sense waveform seen at CS pin in V/s
- $R_{CS}$  is the current sense resistor at CS pin in ohm( $\Omega$ )
- $V_{OUT}$  is the output voltage in volt (V)
- $V_D$  is the forward voltage of freewheeling diode in volt (V)
- $V_{IN}$  is the input voltage in volt(V)
- $L$  is the inductor value in Henry(H)

Since the compensation slope must be at least half, and preferably equal to the down slope of the current sense waveform seen at CS pin, namely,

$$S_e \geq \frac{1}{2} m2$$

Hence, a maximum value is placed on the current sense resistor  $R_{CS}$  when operating in continuous conduction mode at 50% duty cycle or greater.

$$R_{CS} \leq \frac{2 \times 5.5 \times 10^4 \times L}{V_{OUT} + V_D - V_{INmin}}$$

As a conclusion,  $R_{CS}$  should simultaneously meet the requirements of the following 2 equations for inductor over current protection and current mode control purposes:

$$R_{CS} \leq \frac{V_{CS(oc)}}{I_{Lpeak}} = \frac{1-D_{max}}{10 \times I_{omax}}$$

and

$$R_{CS} \leq \frac{2 \times 5.5 \times 10^4 \times L}{V_{OUT} + V_D - V_{INmin}}$$

For design purposes, some margin should be applied to the actual value of the current sense resistor  $R_{CS}$ . As a

# CONSONANCE

starting point, the actual resistor chosen should be 80% or less that the value calculated in the above 2 equations.

## Current Sense Filtering

In most cases, a small filter placed on the CS pin improves performance of the converter. These are the components R4 and C4 in Figure 1. The time constant of this filter should be approximately 100ns. R4 should be less than  $2K\ \Omega$ .

## Freewheeling Diode Selection

For better efficiency and less power dissipation, a low forward voltage schottky diode should be used as the freewheeling diode (D1 in Figure 1), the diode must have a breakdown voltage that is a few volts higher than the output voltage. The diode's average current should be higher than the maximum output current, the diode's peak current should be higher than the inductor's peak current estimated by the following equation:

$$I_{INpeak} = I_{Lpeak} = 1.8 \times \frac{I_{omax}}{1 - D_{max}}$$

## MOSFET Selection

The CN5120 drives an external N-channel MOSFET. The voltage stress on the MOSFET ideally equals the sum of the output voltage and the forward drop of the output diode. In practice, voltage overshoot and ringing occur due to action of circuit parasitic elements during the turn-off transition. The MOSFET voltage rating should be selected with the necessary margin to accommodate this extra voltage stress. A voltage rating of  $1.3 \times V_{OUT}$  provides the necessary design margin in most cases.

The RMS current flowing through the MOSFET is given as:

$$I_{RMS} = \frac{I_{OMAX} \times \sqrt{D_{MAX}}}{(1 - D_{MAX})}$$

So the power dissipation of the MOSFET is given as:

$$PD = I_{RMS}^2 \times R_{dson}$$

Where,  $R_{dson}$  is the on-resistance of the MOSFET.

The MOSFET's power rating and on-resistance should be chosen based on the above equation.

## Output Capacitor Selection

In a boost converter, the output capacitor requirements are demanding due to the fact that the current waveform is pulsed. The choice of component is driven by the acceptable ripple voltage which is affected by the ESR, ESL and bulk capacitance. The total output ripple voltage is:

$$\Delta V_{OUT} = I_{OMAX} \left( \frac{1}{f_{sw} \cdot C_{OUT}} + \frac{I_{esr}}{1 - D_{MAX}} \right)$$

where the first term is due to the bulk capacitance and second term due to the ESR of output capacitor.

For many designs it is possible to choose a single capacitor type that satisfies both the ESR and bulk C requirements. In certain demanding applications, however, the ripple voltage can be improved significantly by connecting two or more types of capacitors in parallel. For example, using a low ESR ceramic capacitor can minimize the ESR step, while an electrolytic capacitor can be used to supply the required bulk C.

The output capacitor in a boost regulator experiences high RMS ripple currents. The RMS output capacitor ripple current is:

# CONSONANCE

$$I_{RMS(COUT)} \approx I_{O(MAX)} \cdot \sqrt{\frac{V_O - V_{IN(MIN)}}{V_{IN(MIN)}}}$$

Note that the ripple current ratings from capacitor manufacturers are often based on only 2000 hours of life. This makes it advisable to further derate the capacitor or to choose a capacitor rated at a higher temperature than required. Several capacitors may also be placed in parallel to meet size or height requirements in the design.

## Input Capacitor Selection

The input voltage source impedance and cable length determines the size of the input capacitor, which is typically in the range of 10 $\mu$ F to 100 $\mu$ F. A low ESR capacitor or two type of capacitors in parallel is recommended.

The RMS input capacitor ripple current for a boost converter is:

$$I_{RMS(CIN)} = 0.3 \cdot \frac{V_{IN(MIN)}}{L \cdot f} \cdot D_{MAX}$$

Please note that the input capacitor can see a very high surge current when a battery is suddenly connected to the input of the converter and solid tantalum capacitors can fail catastrophically under these conditions.

## Frequency Compensation Network Design

Figure 2 shows the AC response-related circuit of a boost DC-DC Converter using the CN5120.

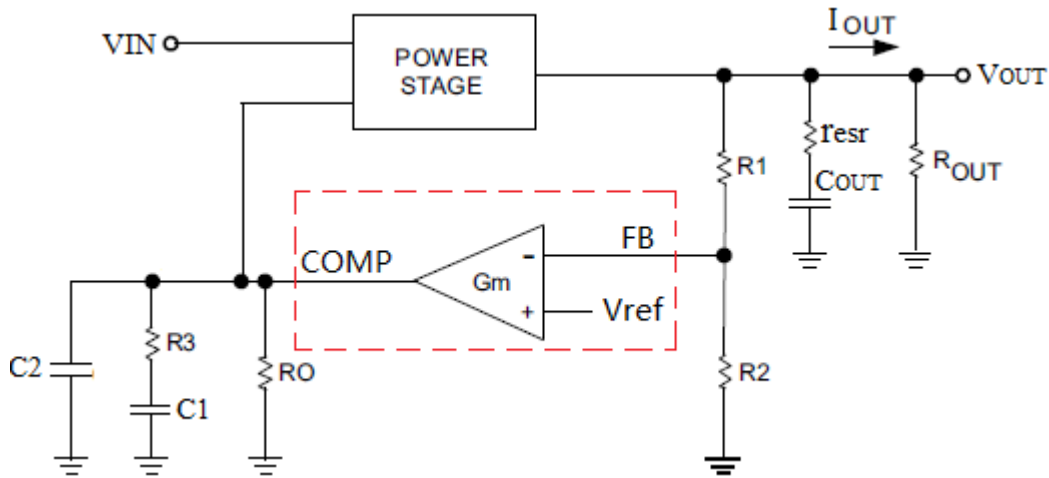

Figure 2 AC Response-Related Circuit

The inductor, output capacitor and the load  $R_{OUT}$  form 1 pole and 2 zeros, they are:

- The pole formed by output capacitor and the load:

$$\omega_{p1} = \frac{2}{R_{OUT} C_{OUT}}$$

- The zero formed by the output capacitor and its equivalent series resistance(ESR)

$$\omega_{z1} = \frac{1}{I_{esr} C_{OUT}}$$

This zero can be neglected if low ESR ceramic capacitor is used.

- A right half plane zero at the frequency:



# CONSONANCE

---

$$\omega_{z2} = \frac{R_{OUT}(1-D)^2}{L}$$

In the above 3 equations,  $R_{OUT}$  is the load resistance,  $C_{OUT}$  is the output capacitance,  $r_{esr}$  is the ESR of output capacitor,  $D$  is the duty cycle, and  $L$  is the inductance.

In Figure 2,  $C1$ ,  $C2$  and  $R3$  form the compensation network. The design procedure of the compensation network is:

**Step 1:** Calculate  $\omega_{p1}$ ,  $\omega_{z1}$  and  $\omega_{z2}$  based on the above 3 equations

**Step 2:** Determine the crossover frequency  $\omega_c$  of the overall loop

For stable operation, the overall loop gain should cross 0dB with -20dB/decade slope. Due to the presence of the RHP zero, the 0dB crossover frequency should be from  $0.3 \times \omega_{z2}$  to  $0.4 \times \omega_{z2}$ .

**Step 3:** Determine  $R3$ 's value in ohm ( $\Omega$ )

$$R3 = 276.6 \cdot V_{OUT} \sqrt{\frac{\omega_c^2}{\omega_{p1}^2} + 1}$$

**Step 4:** Calculate  $C1$ 's value in Farad (F)

$$C1 = \frac{1}{R3 \cdot \omega_{p1}}$$

**Step 5:** Determine  $C2$ 's value in Farad (F)

$R3$  and  $C2$  form a pole used to cancel the effect of  $\omega_{z1}$ . If low ESR capacitor is used for output capacitor,  $\omega_{z1}$  can be neglected, hence  $C2$  can be omitted. Otherwise,  $C2$  can be calculated by the equation:

$$C2 = \frac{1}{R3 \cdot \omega_{z1}}$$

## Board Layout Considerations

Careful PCB design is very important for correct function and good performance. For the application circuit shown in Figure 1, the following suggestions should be followed.

- All connections carrying large pulsed currents must be very short and as wide as possible. The inductance of these connections must be kept to an absolute minimum due to the high di/dt of the currents in the boost DC-DC converter. This implies that the  $C_{IN}$ , inductor, MOSFET, diode and  $C_{OUT}$  should be placed in a compact area. Additionally, small current loop areas reduce radiated EMI.
- The copper plane of the MOSFET should be minimized as much as possible for less EMI.
- The ground plane for the power section of the converter should be kept separate from the analog ground plane. This implies that the negative terminal of  $C_{IN}$ ,  $C_{OUT}$  and current sense resistor  $R_{CS}$  must be close together.
- The CN5120's GND pin and the negative terminal of  $R2$ ,  $C1$ ,  $C2$ ,  $C3$  and  $C4$  in Figure 1 should be connected together and return to the system ground separately.
- For higher output current, multi-layer PCB is recommended.
- Place  $R1$ ,  $R2$ ,  $R3$ ,  $R4$ ,  $C1$ ,  $C2$ ,  $C3$  and  $C4$  as close to the CN5120 as possible.

# CONSONANCE

## Package Information

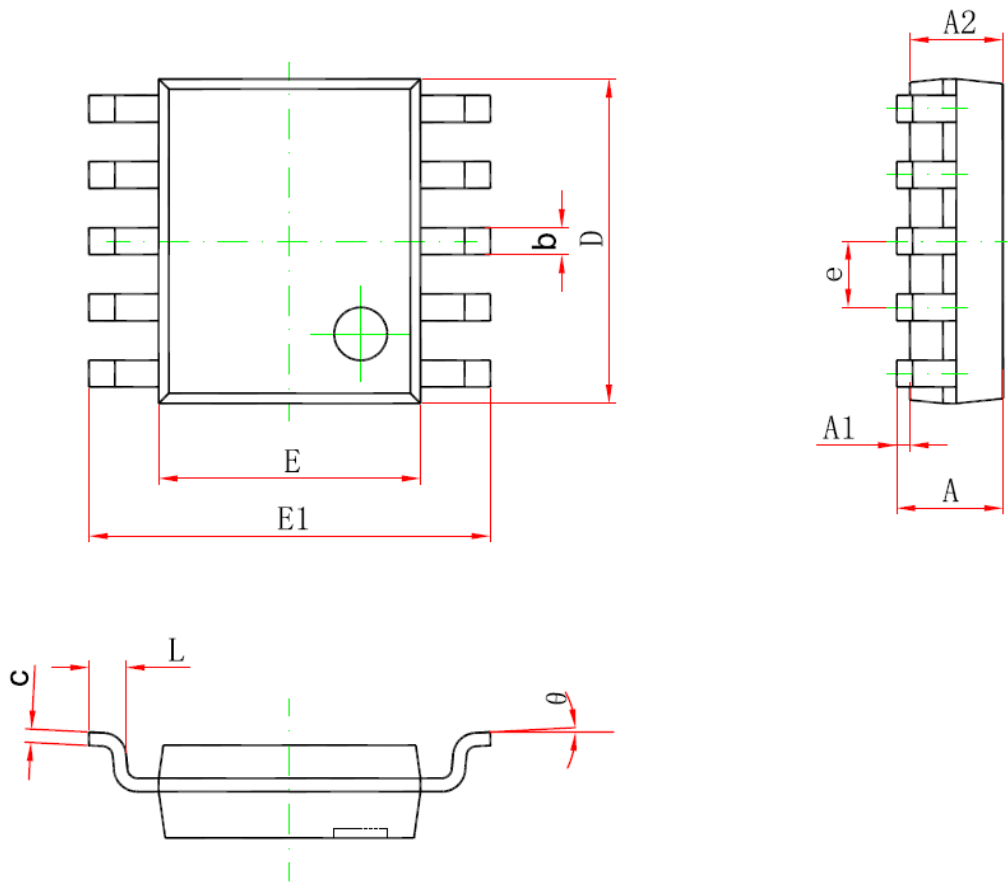

Symbol	Dimensions In Millimeters		Dimensions In Inches	
	Min	Max	Min	Max
A	1.350	1.750	0.053	0.069
A1	0.100	0.250	0.004	0.010
A2	1.350	1.550	0.053	0.061
b	0.300	0.450	0.012	0.018
c	0.170	0.250	0.007	0.010
D	4.700	5.100	0.185	0.201
E	3.800	4.000	0.150	0.157
E1	5.800	6.200	0.228	0.244
e	1.000 (BSC)		0.039 (BSC)	
L	0.400	1.270	0.016	0.050
$\theta$	0°	8°	1°	8°

Consonance does not assume any responsibility for use of any circuitry described. Consonance reserves the right to change the circuitry and specifications without notice at any time.