

# FPC连接器 抽拉式下接 1.0mm间距 26Pin

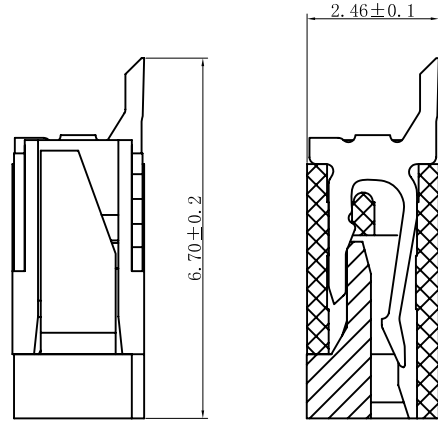
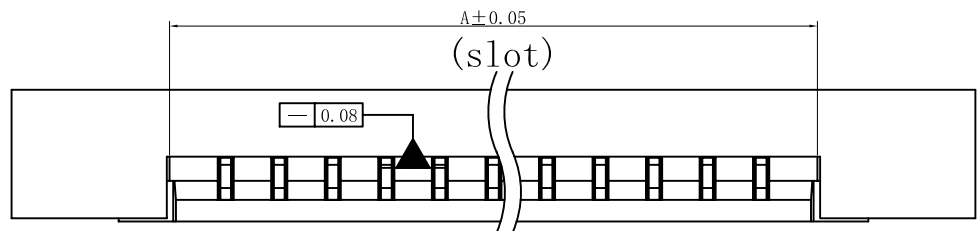
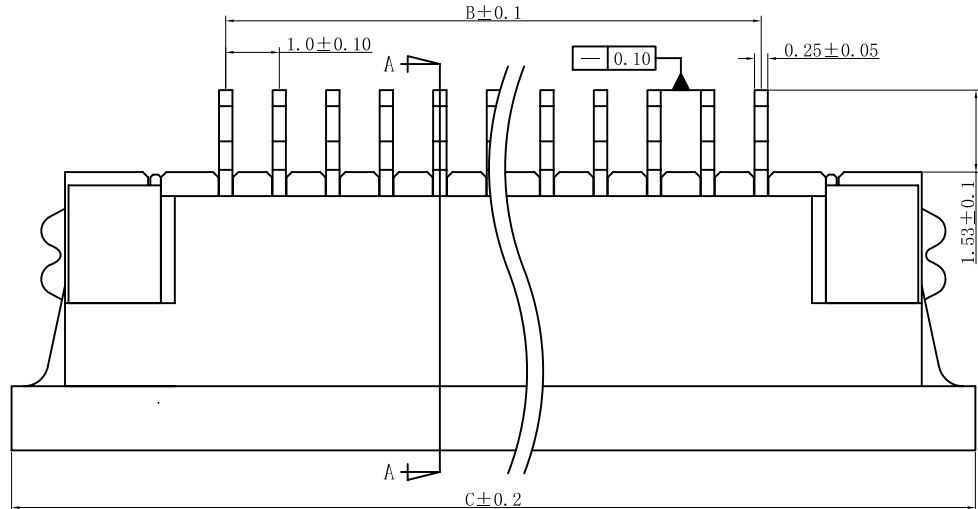

**主要技术特性:**  
 间距: 1.0 mm  
 极数: 4~32  
 额定电压: 50V AC, DC  
 额定电流: 0.5A  
 温度范围: -25℃~+85℃  
 耐压: 200V/min  
 接触电阻: ≤0.04 Ω  
 绝缘电阻: ≥500M Ω

**材料:**  
 壳体: LCP UL94V-0 本色  
 锁扣: LCP UL94V-0 黑色  
 接触针: 磷青铜(镀锡)  
 焊片: 磷青铜(镀锡)

NO. of Contacts (n)	Dimensions		
	A	B	C
4	5.1	3.0	11.0
5	6.1	4.0	12.0
6	7.1	5.0	13.0
7	8.1	6.0	14.0
8	9.1	7.0	15.0
9	10.1	8.0	16.0
10	11.1	9.0	17.0
11	12.1	10.0	18.0
12	13.1	11.0	19.0
13	14.1	12.0	20.0
14	15.1	13.0	21.0
15	16.1	14.0	22.0
16	17.1	15.0	23.0
17	18.1	16.0	24.0
18	19.1	17.0	25.0
19	20.1	18.0	26.0
20	21.1	19.0	27.0
21	22.1	20.0	28.0
22	23.1	21.0	29.0
23	24.1	22.0	30.0
24	25.1	23.0	31.0
25	26.1	24.0	32.0
26	27.1	25.0	33.0
27	28.1	26.0	34.0
28	29.1	27.0	35.0
29	30.1	28.0	36.0
30	31.1	29.0	37.0
31	32.1	30.0	38.0
32	33.1	31.0	39.0

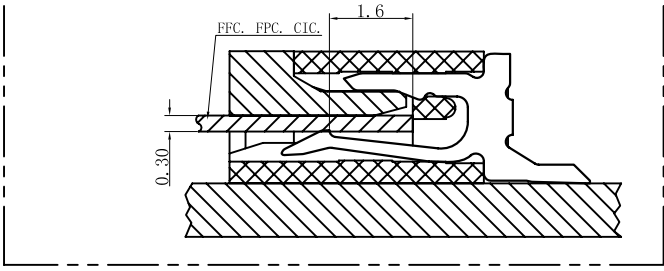
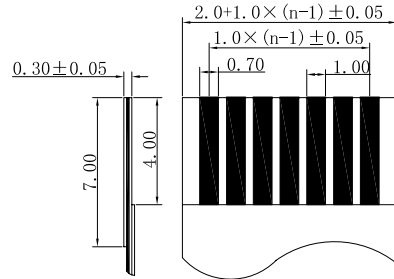
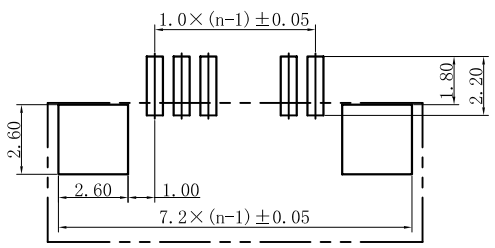
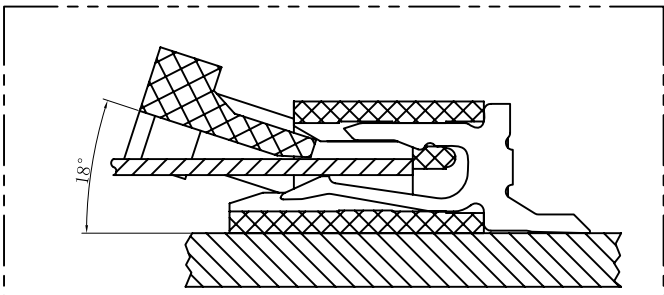

UNITS: mm		NAME: FPC1.0拉拔式半包下接				
GENERAL TOLERANCE		PART NO.(料号)				
X. ° ±5°	0. X ±0.3	APPD:				
X. 1 ±2°	0. XX ±0.2	CHKD:				
XX. ±1°	0. XXX ±0.1	DR:				
XXX. ±0.5°						
				SCALE	SHEET	REV
				1:1	1 OF 1	A