

## PGA302 Sensor Signal Conditioner With 0-5V Ratiometric Output

### 1 Features

- Analog Features
  - Dual Channel Analog Front-End
  - On-Chip Temperature Sensor
  - Programmable Gain up to 200 V/V
  - 16-Bit Sigma-Delta Analog-to-Digital Converter
- Digital Features
  - 3rd-Order Linearity Compensation Algorithm
  - EEPROM Memory for Device Configuration, Calibration Data, and User Data
  - I<sup>2</sup>C Interface
  - One-Wire Interface Through Power Line
- General Features
  - AFE Sensor Input, Power Supply, and Output Buffer Diagnostics
  - Memory Built-In Self-Test (MBIST)
  - Watchdog
  - Power Management Control

### 2 Applications

- Powertrain Pressure Sensors
- Powertrain Exhaust Sensors
- HVAC Sensors
- Seat Occupancy Sensors
- Brake Systems
- Battery Management Systems (BMS)

### 3 Description

The PGA302 is a low-drift, low-noise, programmable signal-conditioner device designed for a variety of resistive bridge-sensing applications like pressure-, temperature-, and level-sensing applications. The PGA302 can also support flow metering applications, weight scale and force-sensing applications that use strain gauge load cells, and other general resistive bridge signal-conditioning applications.

The PGA302 provides a bridge excitation voltage of 2.5 V and a current output source with programmable current output up to 1 mA. At the input, the device contains two identical analog front-end (AFE) channels followed by a 16-bit Sigma-Delta ADC. Each AFE channel has a dedicated programmable gain amplifier with gain up to 200 V/V.

In addition, one of the channels integrates a sensor offset compensation function while the other channel integrates an internal temperature sensor.

At the output of the device, a 1.25-V, 14-bit DAC is followed by a ratiometric-voltage supply output buffer with gain of 4 V/V allowing a 0-5V ratiometric voltage system output. The PGA302 device implements a third-order temperature coefficient (TC) and non-linearity (NL) digital compensation algorithm to calibrate the analog output signal. All required parameters for the linearization algorithm as well as other user data is stored in the integrated EEPROM memory.

#### Device Information<sup>(1)</sup>

PART NUMBER	PACKAGE	BODY SIZE (NOM)
PGA302	TSSOP (16)	5.00 mm x 4.40 mm

(1) For all available packages, see the orderable addendum at the end of the data sheet.

#### PGA302 Simplified Block Diagram

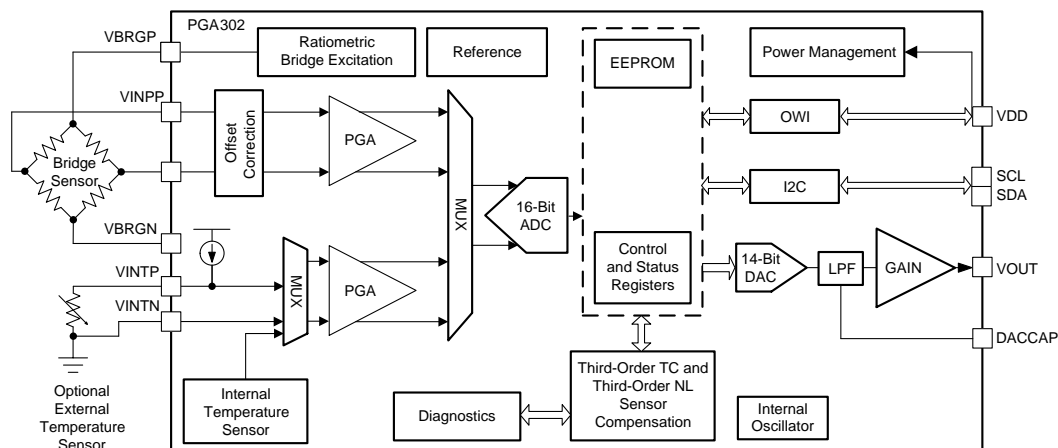

Copyright © 2017, Texas Instruments Incorporated



## Table of Contents

<b>1</b>	<b>Features</b> .....	<b>1</b>	7.18	DAC Gain for DAC Output .....	<b>11</b>
<b>2</b>	<b>Applications</b> .....	<b>1</b>	7.19	Non-Volatile Memory .....	<b>13</b>
<b>3</b>	<b>Description</b> .....	<b>1</b>	7.20	Diagnostics - PGA30x .....	<b>13</b>
<b>4</b>	<b>Revision History</b> .....	<b>2</b>	7.21	Typical Characteristics .....	<b>14</b>
<b>5</b>	<b>Description (continued)</b> .....	<b>3</b>	<b>8</b>	<b>Detailed Description</b> .....	<b>15</b>
<b>6</b>	<b>Pin Configuration and Functions</b> .....	<b>3</b>	8.1	Overview .....	<b>15</b>
<b>7</b>	<b>Specifications</b> .....	<b>4</b>	8.2	Functional Block Diagram .....	<b>16</b>
7.1	Absolute Maximum Ratings .....	<b>4</b>	8.3	Feature Description .....	<b>17</b>
7.2	ESD Ratings .....	<b>4</b>	8.4	Device Functional Modes .....	<b>38</b>
7.3	Recommended Operating Conditions .....	<b>4</b>	8.5	Register Maps .....	<b>39</b>
7.4	Thermal Information .....	<b>5</b>	<b>9</b>	<b>Application and Implementation</b> .....	<b>65</b>
7.5	Overvoltage and Reverse Voltage Protection .....	<b>5</b>	9.1	Application Information .....	<b>65</b>
7.6	Linear Regulators .....	<b>5</b>	9.2	Typical Application .....	<b>66</b>
7.7	Internal Reference .....	<b>5</b>	<b>10</b>	<b>Power Supply Recommendations</b> .....	<b>68</b>
7.8	Internal Oscillator .....	<b>5</b>	<b>11</b>	<b>Layout</b> .....	<b>69</b>
7.9	Bridge Sensor Supply .....	<b>6</b>	11.1	Layout Guidelines .....	<b>69</b>
7.10	Temperature Sensor Supply .....	<b>6</b>	11.2	Layout Example .....	<b>69</b>
7.11	Bridge Offset Cancel .....	<b>7</b>	<b>12</b>	<b>Device and Documentation Support</b> .....	<b>70</b>
7.12	P Gain and T Gain Input Amplifiers (Chopper Stabilized) .....	<b>7</b>	12.1	Receiving Notification of Documentation Updates .....	<b>70</b>
7.13	Analog-to-Digital Converter .....	<b>8</b>	12.2	Community Resources .....	<b>70</b>
7.14	Internal Temperature Sensor .....	<b>9</b>	12.3	Trademarks .....	<b>70</b>
7.15	Bridge Current Measurement .....	<b>10</b>	12.4	Electrostatic Discharge Caution .....	<b>70</b>
7.16	One Wire Interface .....	<b>10</b>	12.5	Glossary .....	<b>70</b>
7.17	DAC Output .....	<b>10</b>	<b>13</b>	<b>Mechanical, Packaging, and Orderable Information</b> .....	<b>70</b>

## 4 Revision History

DATE	REVISION	NOTES
December 2017	*	Initial release.

## 5 Description (continued)

For system connectivity the PGA302 device integrates an I<sup>2</sup>C Interface as well as a one-wire interface (OWI) that supports communication and configuration through the power-supply line during final system calibration process. Diagnostics are implemented at the excitation output sources, the input to the AFE and the power supplies in the device. System Diagnostics like sensor open / short are also supported.

PGA302 accommodates various sensing element types, such as piezoresistive, ceramic film, strain gauge, and steel membrane. The device can also be used in accelerometer, humidity sensor signal-conditioning applications, as well as in some current-sensing, shunt-based applications.

## 6 Pin Configuration and Functions

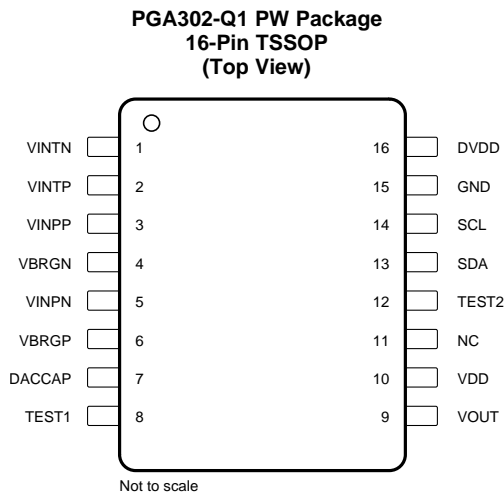

### Pin Functions

PIN		TYPE	DESCRIPTION
NO.	NAME		
1	VINTN	I	External temperature sensor - negative input
2	VINTP	I	External temperature sensor - positive input
3	VINPP	I	Resistive sensor - positive input
4	VBRGN	O	Bridge drive negative
5	VINPN	I	Resistive sensor - negative input
6	VBRGP	O	Bridge drive positive
7	DACCAP	I/O	DAC LPF capacitor
8	TEST1	O	Test pin 1
9	VOUT	O	Analog voltage output (from DAC gain amplifier)
10	VDD	P	Power supply voltage
11	NC	-	No connect
12	TEST2	O	Test pin 2
13	SDA	I/O	I <sup>2</sup> C interface serial data pin
14	SCL	I	I <sup>2</sup> C interface serial clock pin
15	GND	P	Ground
16	DVDD	P	Digital logic regulator capacitor

## 7 Specifications

### 7.1 Absolute Maximum Ratings<sup>(1)</sup>

		MIN	MAX	UNIT
V <sub>DD</sub>	VDD voltage	-20	20	V
V <sub>OUT</sub>	VOUT voltage	-20	20	V
	Voltage at VP_OTP	-0.3	8	V
	Voltage at sensor input and drive pins	-0.3	5	V
	Voltage at any IO pin	-0.3	2	V
I <sub>DD, Short on VOUT</sub>	Supply current		25	mA
T <sub>Jmax</sub>	Maximum junction temperature		155	°C
T <sub>lead</sub>	Lead temperature (soldering, 10 s)		260	°C
T <sub>stg</sub>	Storage temperature	-40	150	°C

- (1) Stresses beyond those listed under *Absolute Maximum Ratings* may cause permanent damage to the device. These are stress ratings only and functional operation of the device at these or any other conditions beyond those indicated under *Recommended Operating Conditions* are not implied. Exposure to Absolute-Maximum-Rated conditions for extended periods may affect device reliability.

### 7.2 ESD Ratings

			VALUE	UNIT	
V <sub>(ESD)</sub>	Electrostatic discharge	Human-body model (HBM), per ANSI/ESDA/JEDEC JS-001 <sup>(1)</sup>	All pins except 9 and 10	±2000	V
			Pins 9 and 10	±4000	
		Charged-device model (CDM), per JEDEC specification JESD22-C101 <sup>(2)</sup>	All pins except 1, 8, 9, and 16	±500	
			Pins 1, 8, 9, and 16	±750	

- (1) JEDEC document JEP155 states that 500-V HBM allows safe manufacturing with a standard ESD control process.  
 (2) JEDEC document JEP157 states that 250-V CDM allows safe manufacturing with a standard ESD control process.

### 7.3 Recommended Operating Conditions

over operating free-air temperature range (unless otherwise noted)

			MIN	NOM	MAX	UNIT
V <sub>DD</sub>	Power supply voltage		4.5	5	5.5 <sup>(1)</sup>	V
	Slew Rate	V <sub>DD</sub> = 0 to 5 V; decoupling capacitor on VDD = 10 nF			5	V/ns
I <sub>DD</sub>	Power supply current - Normal Operation	No load on VBRG, No load on DAC		6.5	10	mA
T <sub>A</sub>	Operating ambient temperature		-40		150	°C
	Programming temperature	EEPROM	-40		140	°C
	Start-up time (including analog and digital)	VDD ramp rate 1 V/μs			250	μs
	Capacitor on VDD Pin	Not including series resistance		100		nF

- (1) The analog circuits in the device will be shut off for VDD > OVP. However, digital logic inside the device will continue to operate. The device will withstand VDD < VDD\_ABSMAX without damage

## 7.4 Thermal Information

THERMAL METRIC <sup>(1)</sup>		PGA302		UNIT
		PW (TSSOP)		
		16 PINS		
R <sub>θJA</sub>	Junction-to-ambient thermal resistance	96.8		°C/W
R <sub>θJC(top)</sub>	Junction-to-case (top) thermal resistance	27.3		°C/W
R <sub>θJB</sub>	Junction-to-board thermal resistance	43.3		°C/W
ψ <sub>JT</sub>	Junction-to-top characterization parameter	1.2		°C/W
ψ <sub>JB</sub>	Junction-to-board characterization parameter	42.7		°C/W

(1) For more information about traditional and new thermal metrics, see the [IC Package Thermal Metrics](#) application report.

## 7.5 Overvoltage and Reverse Voltage Protection

over operating free-air temperature range (unless otherwise noted)

PARAMETER	TEST CONDITIONS	MIN	TYP	MAX	UNIT
Reverse voltage		-20			V
Overvoltage analog shutdown	-40°C to 150°C	5.65			V

## 7.6 Linear Regulators

PARAMETER	TEST CONDITIONS	MIN	TYP	MAX	UNIT
V <sub>DVDD</sub>	DVDD voltage - operating Capacitor on DVDD pin = 100 nF	1.76	1.8	1.86	V
V <sub>DVDD_POR</sub>	DVDD voltage - digital POR	1.4	1.6	1.75	V
	DVDD voltage - digital POR Hysteresis		0.1		V
V <sub>VDD_POR</sub>	VDD voltage - digital POR	4			V
	VDD voltage - digital POR Hysteresis		0.1		V

## 7.7 Internal Reference

over operating free-air temperature range (unless otherwise noted)

PARAMETER	TEST CONDITIONS	MIN	TYP	MAX	UNIT
Reference voltage (including reference buffer)			2.5		V
Reference initial error		-0.5%		0.5%	
Reference voltage TC		-250		250	ppm/°C
PSRR	VDD Ripple Conditions: <ul style="list-style-type: none"> <li>VDD DC Level = 5 V</li> <li>VDD Ripple Amplitude = 100 mV</li> <li>VDD Ripple Frequency Range: 30 Hz to 50 KHz</li> <li>Calculate PSRR using the formula: 20log<sub>10</sub>(Amplitude of Reference Voltage/Amplitude of VDD ripple)</li> </ul>		-35		dB

## 7.8 Internal Oscillator

PARAMETER	TEST CONDITIONS	MIN	TYP	MAX	UNIT
<b>INTERNAL OSCILLATOR</b>					
Internal oscillator frequency	T <sub>A</sub> = 25°C		8		MHz
Internal oscillator frequency variation	Across operating temperature	-3%		3%	

## 7.9 Bridge Sensor Supply

PARAMETER		TEST CONDITIONS	MIN	TYP	MAX	UNIT
<b>VBRG SUPPLY FOR RESISTIVE BRIDGE SENSORS</b>						
$V_{BRGF}-V_{BRGN}$	Bridge supply voltage	$I_{LOAD} = 0$ to 8.5mA	2.4	2.5	2.6	V
$P_{MISMATCH}$	Mismatch between bridge supply voltage, temperature variation, and ADC reference temperature variation	Procedure to calculate drift mismatch: 1. VDD = 5 V 2. Connect 5-K $\Omega$ , Zero TC bridge with 5mV output to device 3. Set P GAIN = 200V/V 4. Set Temperature = 25°C, Measure ADC Code by averaging 512 samples 5. Set Temperature = -40°C, Measure ADC Code by averaging 512 samples 6. Set Temperature = 125°C, Measure ADC Code by averaging 512 samples 7. Calculate Drift using the formula: (ADC Code at Temperature – ADC Code at 25°C)/((ADC Code at 25°C)×(Temperature – 25))	-250		+250	ppm/°C
$I_{BRG}$	Current Supply to the Bridge				8.5	mA
	Bridge short-circuit current limit	$T_A = 25^\circ\text{C};$ $V_{VDD} = 5\text{ V}$	9		25	mA
$C_{BRG}$	Capacitive Load	$R_{BRG} = 5\text{ k}\Omega$			2	nF

## 7.10 Temperature Sensor Supply

PARAMETER		TEST CONDITIONS	MIN	TYP	MAX	UNIT
<b>ITEMP SUPPLY FOR TEMPERATURE SENSOR<sup>(1)</sup></b>						
$I_{TEMP}$	Current supply to temperature sensor	Control bit = 0b000	45	50	55	$\mu\text{A}$
		Control bit = 0b001	90	100	110	
		Control bit = 0b010	180	200	220	
		Control bit = 0b011	850	1000	1150	
		Control bit = 0b1xx		OFF		
$T_{MISMATCH}$	Mismatch between ITEMp temperature variation and ADC reference temperature variation	Procedure to calculate drift mismatch: 1. VDD = 5 V 2. Connect 1-K $\Omega$ , Zero TC resistor to the temperature input pins of device 3. Set T GAIN = 1.33 V/V 4. Set ITEMp = 100 $\mu\text{A}$ 5. Set Temperature = 25°C, Measure ADC Code by averaging 512 samples 6. Set Temperature = -40°C, Measure ADC Code by averaging 512 samples 7. Set Temperature = 125°C, Measure ADC Code by averaging 512 samples 8. Calculate Drift using the formula: (ADC Code at Temperature – ADC Code at 25°C)/((ADC Code at 25°C)×(Temperature – 25))	-250		+250	ppm/°C
$Z_{OUT}$	Output Impedance	Ensured by design	15			M $\Omega$
$C_{TEMP}$	Capacitive load				100	nF

(1) Not applicable for 8-pin package options

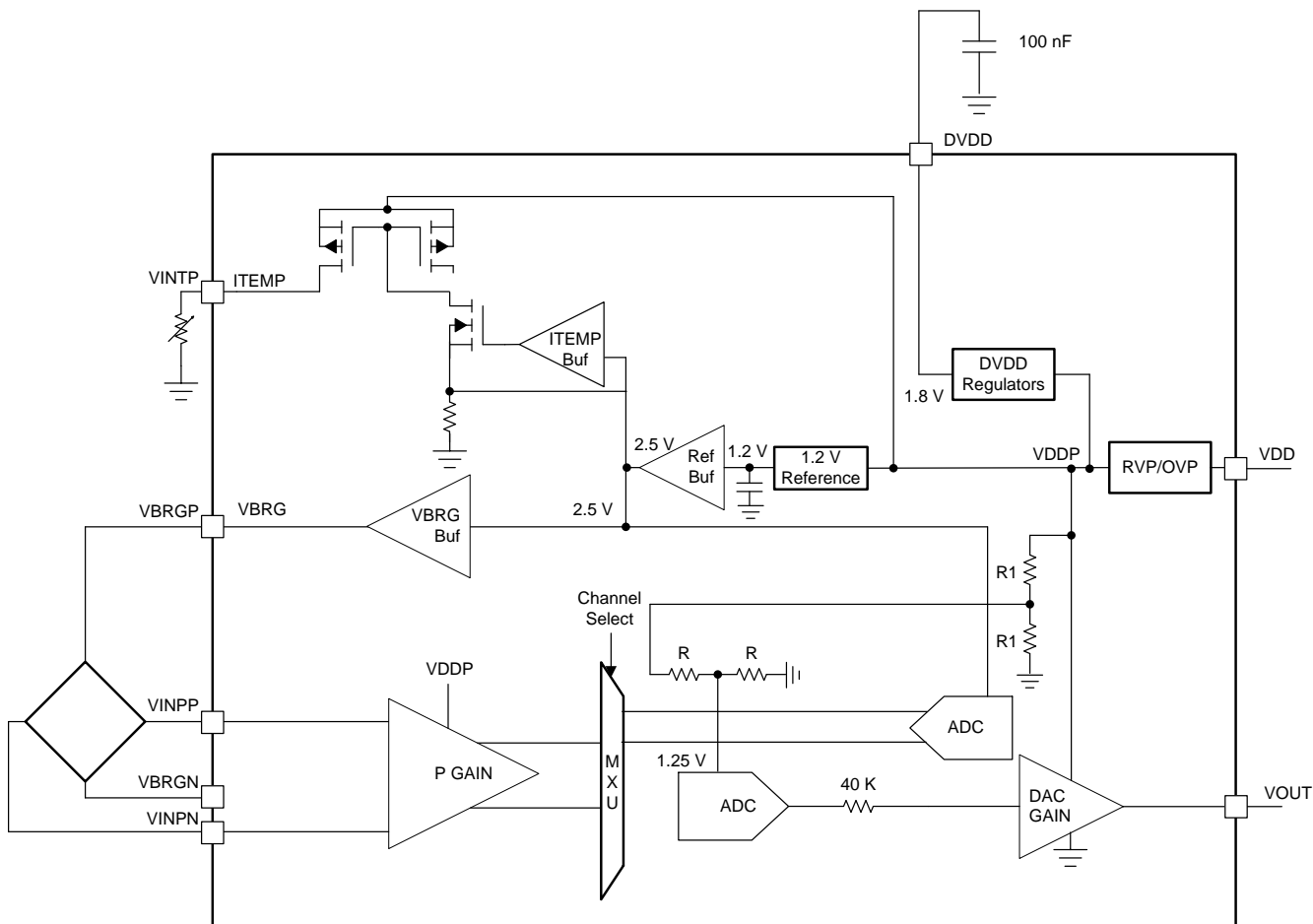

Copyright © 2017, Texas Instruments Incorporated

Figure 1. Bridge Supply and ADC Reference are Ratiometric

### 7.11 Bridge Offset Cancel

over operating free-air temperature range (unless otherwise noted)

PARAMETER	TEST CONDITIONS	MIN	TYP	MAX	UNIT
Offset cancel range		-54.75		+54.75	mV
Offset cancel tolerance		-10%		+10%	
Offset cancel resolution (4 bits)			10		mV

### 7.12 P Gain and T Gain Input Amplifiers (Chopper Stabilized)

PARAMETER	TEST CONDITIONS	MIN	TYP	MAX	UNIT
Gain steps (3 bits)	000, at DC	1.31	1.33	1.35	V/V
	001	1.97	2	2.03	
	010	3.92	4	4.08	
	011	9.6	10	10.4	
	100	19	20	21	
	101	38	40	42	
	110	96	100	104	
	111	185	200	215	

**P Gain and T Gain Input Amplifiers (Chopper Stabilized) (continued)**

PARAMETER	TEST CONDITIONS	MIN	TYP	MAX	UNIT
Bandwidth	PGAIN = 1.33		680		kHz
	PGAIN = 2		470		
	PGAIN = 4		250		
	PGAIN = 10		104		
	PGAIN = 20		80		
	PGAIN = 40		72		
	PGAIN = 100		30		
	PGAIN = 200		15		
Input offset voltage			14		μV
Gain temperature drift	Gain = 200 V/V	-250		+250	ppm/°C
Input bias current			5		nA
Common-mode voltage range			Depends on Selected Gain, Bridge Supply and Sensor Span <sup>(1)</sup>		V
Common-mode rejection ratio	F <sub>CM</sub> = 50 Hz; ensured by design	110			dB
Input impedance	Ensured by design	10			MΩ

**(1) Common Mode at P Gain Input and Output:**

(a) The single-ended voltage of positive/negative pin at the Gain input should be between +0.02 V and +4.38 V

**7.13 Analog-to-Digital Converter**

PARAMETER	TEST CONDITIONS	MIN	TYP	MAX	UNIT
Sigma delta modulator frequency			4		MHz
ADC voltage input range		-2.5		2.5	V
Number of bits			16		bits
ADC 2's complement code for -2.5-V differential input	2's Complement		8000 <sub>hex</sub>		LSB
ADC 2's complement code for 0-V differential input			0000 <sub>hex</sub>		LSB
ADC 2's complement code for 2.5-V differential input			7FFF <sub>hex</sub>		LSB
Output sample period (no latency)	Sample period control bit = 0b00		96		μs
ADC multiplexer switching time				1	μs



**Analog-to-Digital Converter (continued)**

PARAMETER	TEST CONDITIONS	MIN	TYP	MAX	UNIT
Effective number of bits (ENOB)	Procedure to calculate ENOB: 1. VDD = 5 V 2. Temperature = -40°C, 25°C, 125°C, 150°C 3. Connect 5-KΩ, Zero TC bridge to the pressure input pins device with near zero differential voltage 4. Set P GAIN = 200 V/V 5. Set ADC sample period to 96 μS 6. Set input MUX to pressure channel 7. Measure ADC 8. Calculate ENOB using the formula: $20\log_{10}((32768/2/\sqrt{2})/(\text{ADC code rms}))/6.02$	11.4			bits
ENOB in the presence of crosstalk between P and T channels	Procedure to calculate ENOB in the presence of crosstalk: 1. VDD = 5 V 2. Temperature = -40°C, 25°C, 125°C, 150°C 3. Connect 5-KΩ, Zero TC bridge to the pressure input pins device 4. Set P GAIN = 200 V/V 5. Set ADC sample period to 96 μS 6. Connect 1-KHz, 1.25-V common mode, 1-Vpp sine wave through 100-Ω source impedance to temperature input pins device 7. Set T GAIN = 1.33 V/V 8. Set input MUX to pressure channel 9. Measure ADC 10. Calculate ENOB using the formula: $20\log_{10}((32768/2/\sqrt{2})/(\text{ADC code rms}))/6.02$	11.4			bits
Linearity	Procedure to calculate Linearity: 1. VDD = 5 V 2. Temperature = 25°C 3. Connect 5-KΩ, Zero TC bridge to the pressure input pins of the device with 30%FS to 70%FS input voltages 4. Set GAIN = 200 V/V 5. Set ADC sample period to 96 μS 6. Set input MUX to pressure channel 7. Measure P ADC 8. Calculate linearity as maximum deviation obtaining using end-point fit		±0.8		%FS

**7.14 Internal Temperature Sensor**

PARAMETER	TEST CONDITIONS	MIN	TYP	MAX	UNIT
Internal temperature sensor range		-40		150	°C
Gain <sup>(1)</sup>	16-bit ADC		20		LSB/°C
Offset			5700		LSB

(1) ADC = Gain × Temperature + offset

## Internal Temperature Sensor (continued)

PARAMETER	TEST CONDITIONS	MIN	TYP	MAX	UNIT
Total error after calibration using typical gain and offset values <sup>(2)</sup>			±6		°C

(2) TI does not calibrate the sensor. User has to calibrate the internal temperature sensor on their production line.

## 7.15 Bridge Current Measurement

PARAMETER	TEST CONDITIONS	MIN	TYP	MAX	UNIT
Bridge current range		0		8500	µA
Gain if T GAIN is configured for 1.33 Gain			2250		LSB/mA
Offset T GAIN is configured for 1.33 Gain			2075		LSB
Total temperature drift	Procedure to calculate Total Temperature Drift: 1. VDD = 5 V 2. Temperature = -40°C, 25°C, 125°C, 150°C 3. Connect 5-KΩ, Zero TC bridge to the pressure input pins device with near zero differential voltage 4. Set T GAIN = 1.33 V/V 5. Set input MUX to bridge current 6. Measure T ADC 7. Filter ADC code using 10-Hz 1st order filter 8. Calculate Total Temperature Drift using the formula: (ADC code at Temperature – ADC code at 25°C)/(Temperature – 25°C)/(ADC code at 25°C) × 1e6		600		ppm/°C

## 7.16 One Wire Interface

PARAMETER	TEST CONDITIONS	MIN	TYP	MAX	UNIT
Communication baud rate		2400		9600	bits per second
OWI_ENH OWI activation high		OWI_ENL			V
OWI_ENL OWI activation low				6.8	V
OWI_LOW Activation signal pulse low time	OWI_DGL_CNT_SEL = 0	1			ms
	OWI_DGL_CNT_SEL = 1	10			
OWI_HIGH Activation signal pulse high time	OWI_DGL_CNT_SEL = 0	1			ms
	OWI_DGL_CNT_SEL = 1	10			
OWI_VIH OWI transceiver Rx threshold for high		5.3			V
OWI_VIL OWI transceiver Rx threshold for low				4.7	V
OWI_IOH OWI transceiver Tx threshold for high		900		1300	µA
OWI_IOL OWI transceiver Tx threshold for low		2		5	µA

## 7.17 DAC Output

PARAMETER	TEST CONDITIONS	MIN	TYP	MAX	UNIT
DAC Reference Voltage	Ratiometric Reference		0.25 × V <sub>ddp</sub>		V
DAC Resolution			14		Bits

## 7.18 DAC Gain for DAC Output

PARAMETER	TEST CONDITIONS	MIN	TYP	MAX	UNIT
Buffer gain (see <a href="#">Figure 2</a> )		3.9	4	4.3	V/V
Gain bandwidth product	No Load, No DACCAP, Nominal Gain		1		MHz
Offset error (includes DAC errors)	Calculate Gain Nonlinearity at VDD = 5 V and 25°C as follows: <ol style="list-style-type: none"> <li>1. Apply DAC Code = 819d at 25°C and 0-mA load and measure voltage at VOUT</li> <li>2. Apply DAC Code = 8192d at 25°C and 0-mA load and measure voltage at VOUT</li> <li>3. Apply DAC Code = 15564d at 25°C and 0-mA load and measure voltage at VOUT</li> <li>4. Linear Curve-fit the three measurements using end-point method and determine offset</li> </ol>		±20		mV
Gain nonlinearity (includes DAC errors)	Calculate Gain Nonlinearity at VDD = 5 V and 25°C as follows: <ol style="list-style-type: none"> <li>1. Apply DAC Code = 819d at 25°C and 0-mA load and measure voltage at VOUT</li> <li>2. Apply DAC Code = 8192d at 25°C and 0-mA load and measure voltage at VOUT</li> <li>3. Apply DAC Code = 15564d at 25°C and 0-mA load and measure voltage at VOUT</li> <li>4. Linear Curve-fit the three measurements using end-point method and determine nonlinearity</li> </ol>		±600		µV
Total unadjusted error	Calculate Gain Nonlinearity at VDD = 5 V and 25°C as follows: <ol style="list-style-type: none"> <li>1. Apply DAC Code = 819d at 25°C and 0-mA load and measure voltage at VOUT</li> <li>2. Apply DAC Code = 8192d at 25°C and 0-mA load and measure voltage at VOUT</li> <li>3. Apply DAC Code = 15564d at 25°C and 0-mA load and measure voltage at VOUT</li> <li>4. Linear Curve-fit the three measurements using end-point method and determine total unadjusted error by comparing values against ideal line. Error is w.r.t. 4V FS.</li> </ol>	-2		2	%FSO
Ratiometric error due to change in temperature and load current for DAC code = 819d to 15564d.	Calculate ratiometric error at VDD = 5 V and at DAC codes as follows: <ol style="list-style-type: none"> <li>1. Apply DAC Code at 25°C and 0-mA load, and measure voltage at VOUT</li> <li>2. Change temperature between -40°C to 150°C, and measure voltage at VOUT</li> <li>3. Change load current between 0 mA to 2.5 mA, and measure voltage at VOUT</li> <li>4. Ratiometric Error = ((VOUT at TEMPERATURE at LOAD) – (VOUT at 25°C at 0 mA))</li> </ol>	-10		10	mV

### DAC Gain for DAC Output (continued)

PARAMETER	TEST CONDITIONS	MIN	TYP	MAX	UNIT
Ratiometric error due to change in VDD for DAC code = 819d to 15564d.	Calculate ratiometric error at DAC codes as follows: 1. Apply DAC Code at 25°C and 0-mA load, and measure voltage at VOUT 2. Change VDD between 4.5 V and 5.5 V, and measure voltage at VOUT 3. Change temperature between -40°C to 150°C, and measure voltage at VOUT 4. Ratiometric Error = ((VOUT at VDD, T) – (VOUT at 5 V, 25°C) × VDD/5 V)	-12		12	mV
Settling time (first order response)	DAC Code 819d to 15564d step and C <sub>LOAD</sub> = 100 nF. Output is 99% of Final Value			100	µs
Zero code voltage	DAC code = 0000h, I <sub>DAC</sub> = 1 mA			100 <sup>(1)</sup>	mV
	DAC code = 0000h, I <sub>DAC</sub> = 2.5 mA			250	mV
Full code voltage	Output when DAC code is 3FFFh, I <sub>DAC</sub> = -1 mA	V <sub>ddp</sub> – 0.15 <sup>(1)</sup>			V
	Output when DAC code is 3FFFh, I <sub>DAC</sub> = -2.5 mA	V <sub>ddp</sub> – 0.28			V
Output current	DAC Code = 3FFFh , DAC Code = 0000h			±2.5	mA
Short circuit source current	DAC code = 3FFFh	10		40	mA
Short circuit sink current	DAC code = 0000h	10		40	mA
Output voltage noise (GAIN = 4X)	f = 10 Hz to 1 KHz, VDD = 4.5 V, DAC code = 1FFFh, no capacitor on DACCAP pin, temperature = 25°C		80		µVpp
Pullup resistance		2		47	KΩ
Pulldown resistance		2		47	KΩ
Capacitance		0.1		1000	nF

(1) See Figure for voltage output bands.

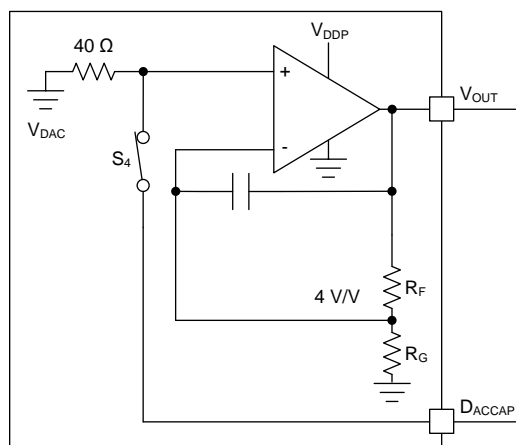

Copyright © 2017, Texas Instruments Incorporated

**Figure 2. PGA302 Output Buffer**

## 7.19 Non-Volatile Memory

PARAMETER		TEST CONDITIONS	MIN	TYP	MAX	UNIT
EEPROM	Size			128		Bytes
	Erase/write cycles				1000	Cycles
	Programming time	1 2-byte page			8	ms
	Data retention			10		Years

## 7.20 Diagnostics - PGA30x

PARAMETER		TEST CONDITIONS	MIN	TYP	MAX	UNIT
VBRG_OV	Resistive bridge sensor supply overvoltage threshold		7.5%			VBRG
VBRG_UV	Resistive bridge sensor supply undervoltage threshold				-4%	VBRG
VDD_OV	VDD OV threshold		5.51			V
DVDD_OV	DVDD OV threshold		1.85			V
REF_OV	Reference overvoltage threshold		2.69			V
REF_UV	Reference undervoltage threshold				2.42	V
P_DIAG_PD	Gain input diagnostics pulldown resistor value	VINPP and VINPN each has pulldown resistor		1		MΩ
				2		
				3		
				4		
T_DIAG_PD	T gain input diagnostics pulldown resistor value	VINTP and VINTN each has pulldown resistor		1		MΩ
VINP_OV	P gain input overvoltage threshold value	VINPP and VINPN each has threshold comparator		90%		VBRDG
				84%		
				78%		
				70%		
VINP_UV	P gain input undervoltage threshold value	VINPP and VINPN each has threshold comparator		10%		VBRDG
				16%		
				24%		
				30%		
VINT_OV	T gain input overvoltage	VINTP and VINTN		90%		VBRG
VINT_UV	T gain input undervoltage			10%		VBRG
PGAIN_OV	P gain output overvoltage			2.5		V
PGAIN_UV	P gain output undervoltage			0.95		V
TGAIN_OV	T gain output overvoltage			2.5		V
TGAIN_UV	T gain output undervoltage			0.67		V
HARNESS_FAULT1	Open wire VOUT voltage - open VDD with pullup on VOUT	Pullup resistor is 2 KΩ to 47 KΩ ±5%, across temperature			5%	VDD
HARNESS_FAULT2	Open wire VOUT voltage - open GND with pulldown on VOUT	Pulldown resistor is 2 KΩ to 47 KΩ ±5%, across temperature	95%			VDD

## 7.21 Typical Characteristics

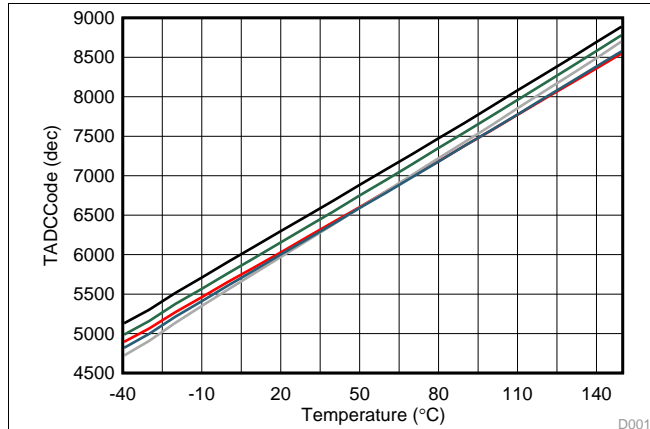

Figure 3. Internal Temperature Sensor

D001

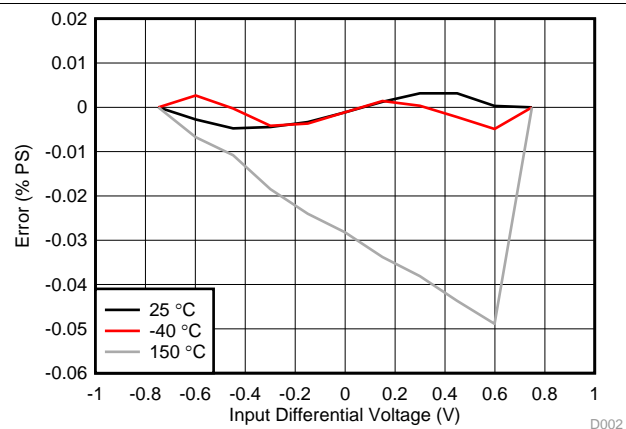

Figure 4. ADE and ADC Linearity Error

D002

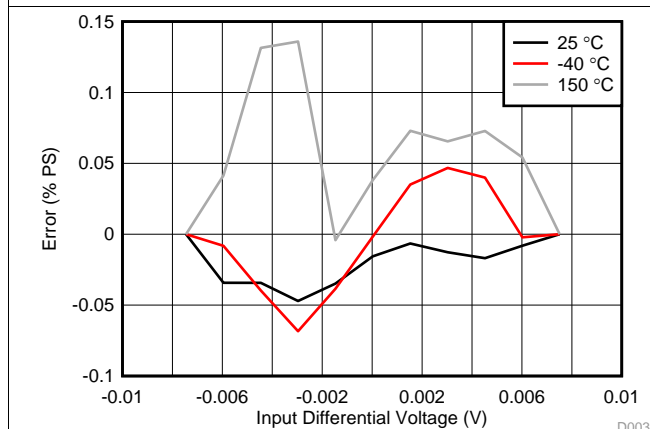

Figure 5. AFE and ADC Linearity Error

D003

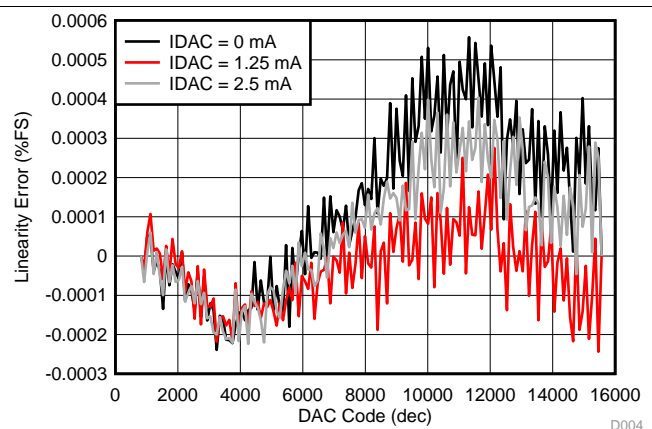

Figure 6. DAC Linearity Error

D004

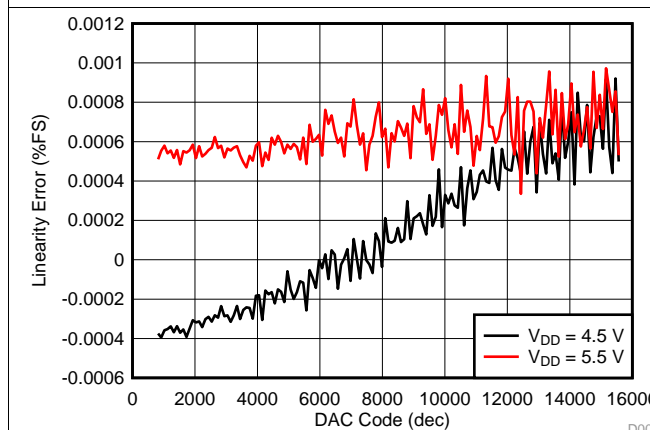

Figure 7. Ratiometric Error vs VDD Supply

D005

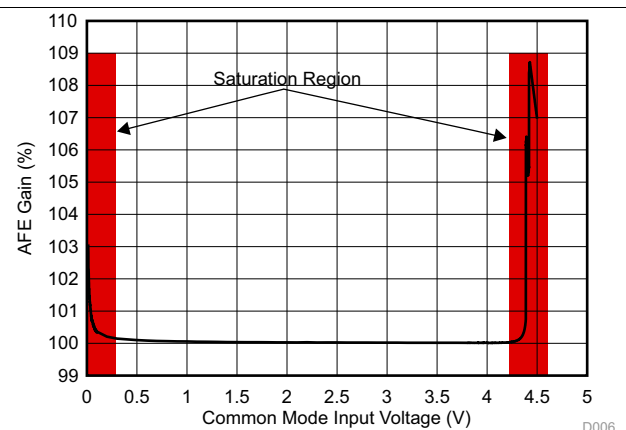

Figure 8. AFE Gain vs Common-Mode Input

D006

## 8 Detailed Description

### 8.1 Overview

The PGA302 is a high accuracy, low drift, low noise, low power, and versatile signal conditioner automotive grade qualified device for resistive bridge pressure and temperature-sensing applications. The PGA302 accommodates various sensing element types, such as piezoresistive, ceramic film, and steel membrane. The typical applications supported are pressure sensor transmitter, transducer, liquid level meter, flow meter, strain gauge, weight scale, thermocouple, thermistor, 2-wire resistance thermometer (RTD), and resistive field transmitters. It can also be used in accelerometer and humidity sensor signal conditioning applications. The PGA302 provides bridge excitation voltages of 2.5 V. The PGA302 conditions sensing and temperature signals by amplification and digitization through the analog front end chain, and performs linearization and temperature compensation. The conditioned signals can be output in analog form. The signal data can also be accessed by an I2C digital interface and a GPIO port. The I2C interface can also be used to configure other function blocks inside the device. The PGA302 has the unique One-Wire Interface (OWI) that supports the communication and configuration through the power supply line. This feature allows to minimize the number of wires needed.

The PGA302 contains two separated analog-front end (AFE) chains for resistive bridge inputs and temperature-sensing inputs. Each AFE chain has its own gain amplifier. The resistive bridge input AFE chain consists of a programmable gain with 8 steps from 1.33 V/V to 200 V/V. For the temperature-sensing input AFE chain, the PGA302 provides a current source that can source up to 1000  $\mu$ A for the optional external temperature sensing. This current source can also be used as a constant current bridge excitation. In addition, the PGA302 integrates an internal temperature sensor which can be configured as the input of the temperature-sensing AFE chain.

The digitalized signals after the ADC decimation filters are sent to the linearization and compensation calculation digital signal logic. A 128-byte EEPROM is integrated in the PGA302 to store sensor calibration coefficients and configuration settings as needed.

The PGA302 has a 14-bit DAC followed by a 4-V/V buffer gain stage. It supports industry standard ratiometric voltage output.

The diagnostic function monitors the operating conditions including power supplies overvoltage, undervoltage, or open AFE faults, DAC faults, and a DAC loopback option to check the integrity of the signal chains. The PGA302 also integrates an oscillator and power management. The PGA302 has a wide ambient temperature operating range from  $-40^{\circ}\text{C}$  to  $+150^{\circ}\text{C}$ . With a small package size, PGA302 has integrated all the functions needed for resistive bridge-sensing applications to minimize PCB area and simplify the overall application design.

## 8.2 Functional Block Diagram

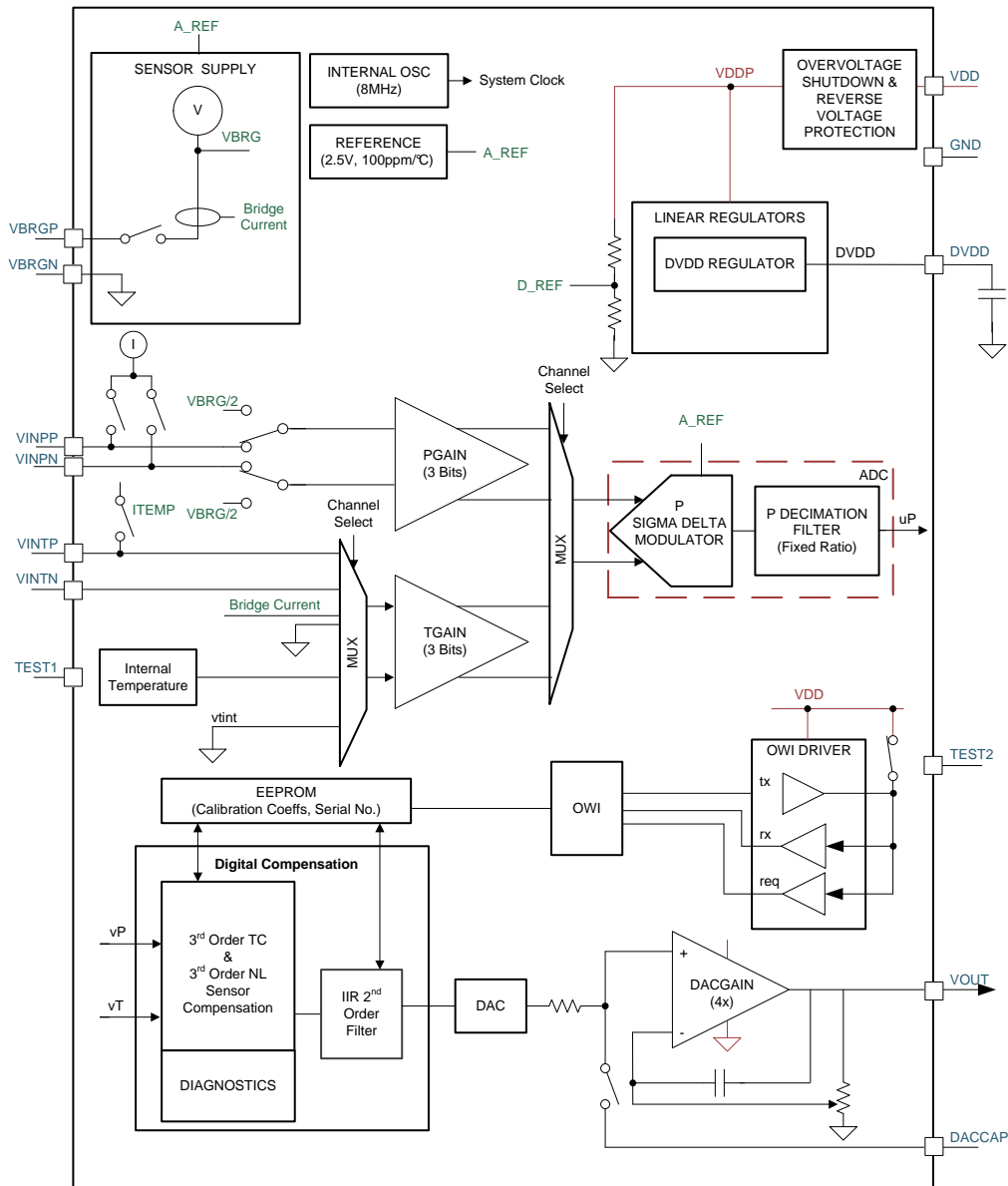



### 8.3 Feature Description

In this section, individual functional blocks are described.

#### 8.3.1 Overvoltage and Reverse Voltage Protection

The PGA302 includes overvoltage protection. This block protects the device from overvoltage conditions on the external power supply and shuts off device operation.

The PGA302 includes reverse voltage protection block. This block protects the device from reverse-battery conditions on the external power supply.

#### 8.3.2 Linear Regulators

The PGA302 has DVDD regulator that provides the 1.8-V regulated voltage for the digital circuitry.

The Power-On Reset signal to the digital core is deasserted when DVDD are in regulation. Figure 9 shows the block diagram representation of the digital power-on-reset (POR) signal generation and Figure 10 shows the digital POR signal assertion and deassertion timing during VDD ramp up and ramp down. This timing shows that during power up, the digital core and the processor remains in reset state until DVDD is at stable levels.

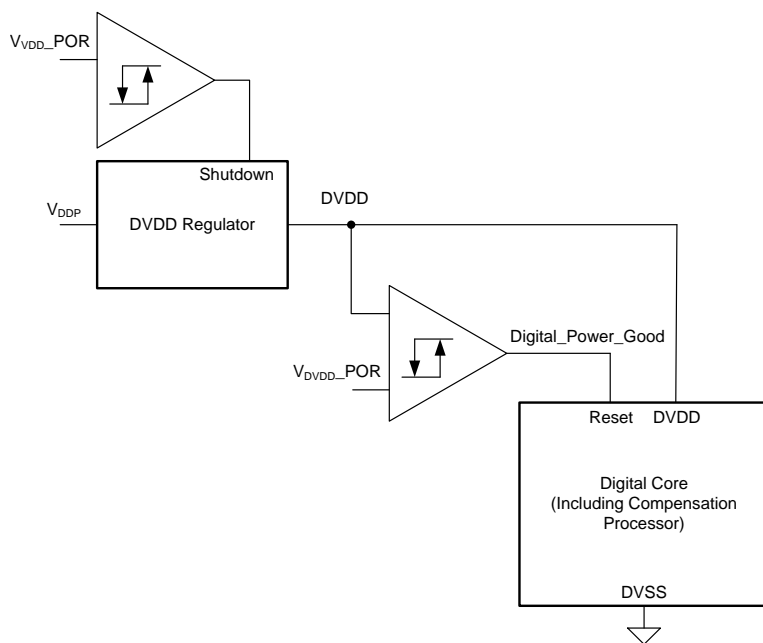

Figure 9. Digital Power-On-Reset Signal Generation

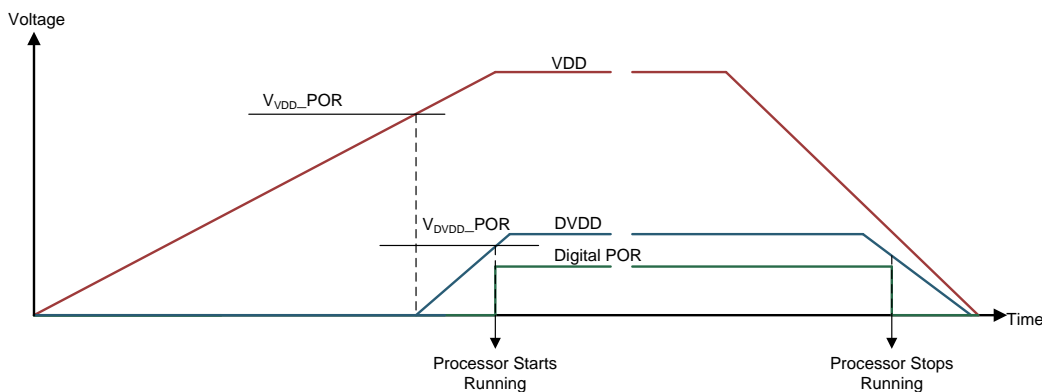

Figure 10. Digital Power-On-Reset Signal Generation

## Feature Description (continued)

### 8.3.3 Internal Reference

PGA302 has internal bandgap reference.

The Reference is used to generate ADC reference voltage and Bridge drive voltage.

#### NOTE

The accurate reference is valid 50  $\mu$ s after digital core starts running at power up.

### 8.3.4 Internal Oscillator

The device includes an internal 8-MHz oscillator. This oscillator provides the internal clock required for the various circuits in PGA302.

### 8.3.5 VBRGP and VBRGN Supply for Resistive Bridge

The Sensor Voltage Supply block of the PGA302 supplies power to the resistive bridge sensor. The sensor supply in the PGA302 is 2.5-V nominal output supply. This nominal supply is ratiometric to the precise internal Accurate Reference.

### 8.3.6 ITEMP Supply for Temperature Sensor

The ITEMP block in PGA302 supplies programmable current to an external temperature sensor such as PTC. The temperature sensor current source is ratiometric to the Reference.

The value of the current can be programmed using the ITEMP\_CTRL bits in TEMP\_CTRL register.

### 8.3.7 P Gain

The P Gain is designed with precision, low drift, low flicker noise, chopper-stabilized amplifiers. The P Gain is implemented as an Instrument Amplifier as shown in [Figure 11](#).

The gain of this stage is adjustable using 3 bits in P\_GAIN\_SELECT register to accommodate sense elements with wide-range of signal spans.

The P Gain amplifier can be configured to measure half-bridge output. In this case, the half bridge can be connected to either VINPP or VINPN pins, while the other pin is internally connected to VBRG/2.

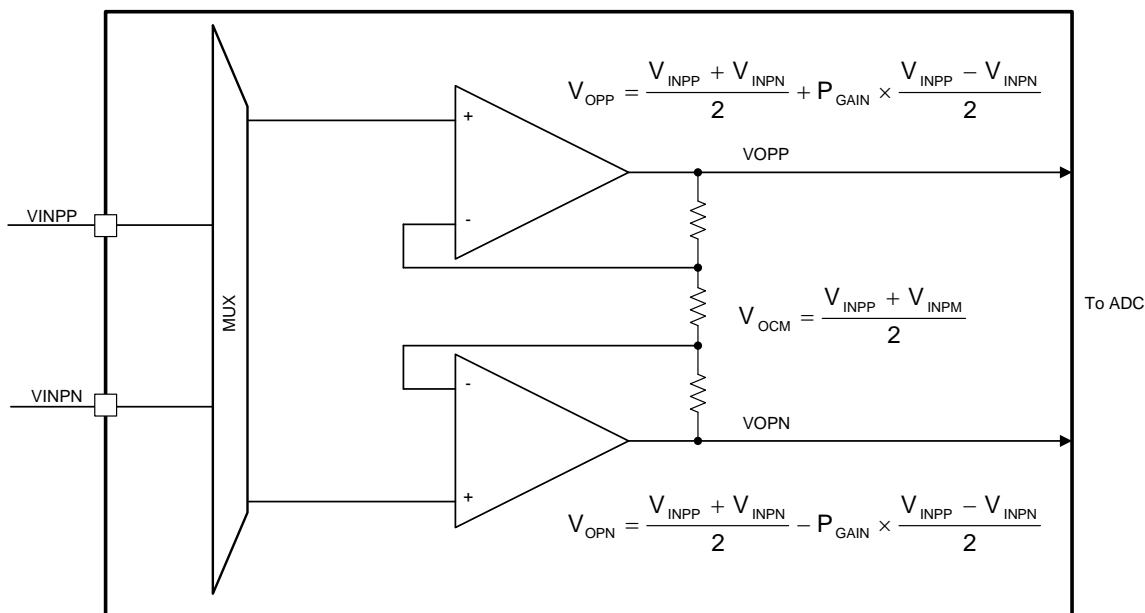

Copyright © 2017, Texas Instruments Incorporated

**Figure 11. P Gain**

## Feature Description (continued)

### 8.3.8 T Gain

The T Gain is designed with precision, low drift, low flicker noise, chopper-stabilized amplifiers. The T Gain is identical in architecture to P Gain.

The gain of this stage is adjustable using 3 bits in T\_GAIN\_SELECT register to accommodate sense elements with wide-range of signal spans.

The T Gain amplifier can be configured to measure the following samples:

- VINTP-VINTN in Differential mode
- VINTP-GND in Single-ended mode
- Internal Temperature sensor voltage in Single-ended mode
- Bridge current in Single-ended mode

### 8.3.9 Bridge Offset Cancel

The PGA302 device implements a bridge offset cancel circuit at the input of the P GAIN in order to cancel large sensor bridge offsets. PGA302 achieves this by introducing a small current into one of the nodes of the bridge prior to the AFE gain. The selection of the offset is determined by the OFFSET\_CANCEL register and the offset values are listed in [Table 1](#).

**Table 1. PGA302 Offset Cancel Implementation**

OFFSET_CANCEL Value	Applied Offset Voltage [mV]
0x00	0 [OFF]
0x01	3.65
0x02	7.3
0x03	10.95
0x04	14.6
0x05	18.28
0x06	21.9
0x07	25.55
0x08	29.2
0x09	32.85
0x0A	36.5
0x0B	40.15
0x0C	43.8
0x0D	47.45
0x0E	51.1
0x0F	54.75

Further the polarity of the applied offset can be changed by setting the OFFSET\_CANCEL\_SEL bit for positive offset or clearing the same bit for negative offset.

### 8.3.10 Analog-to-Digital Converter

The Analog-to-Digital Converter is for digitizing the P and T GAIN amplifier output. The digitized values are available in the respective channel ADC registers.

#### 8.3.10.1 Sigma Delta Modulator for ADC

The sigma-delta modulator for ADC is a 4-MHz, second order, 3-bit quantizer sigma-delta modulator. The sigma-delta modulator can be halted using the ADC\_CFG\_1 register.

#### 8.3.10.2 Decimation Filter for ADC

The decimation filter output rate can be configured for 96  $\mu$ s, 128  $\mu$ s, 192  $\mu$ s or 256  $\mu$ s.

The output of the decimation filter is 16-bit signed 2's complement value. Some example decimation output codes for given differential voltages at the input of the sigma delta modulator as shown in [Table 2](#).

**Table 2. Input Voltage to Output Counts for ADC**

SIGMA DELTA MODULATOR DIFFERENTIAL INPUT VOLTAGE	16-BIT NOISE-FREE DECIMATOR OUTPUT
-2.5 V	-32768 (0x8000)
-1.25 V	-16384 (0xC000)
0 V	0 (0x0000)
1.25 V	16383 (0x3FFF)
2.5 V	32767 (0x7FFF)

**8.3.10.3 Internal Temperature Sensor ADC Conversion**

The nominal relationship between the device junction temperature and 16-bit T GAIN ADC Code for T GAIN = 4 V/V is shown in [Equation 1](#)

$$T \text{ ADC Code} = 20 \times \text{TEMP} + 5700$$

where

- TEMP is temperature in °C.

(1)

[Table 3](#) shows ADC output for some example junction temperature values.

**Table 3. Internal Temperature Sensor to ADC Value**

INTERNAL TEMPERATURE	16-BIT ADC NOMINAL VALUE
-40°C	4900 (0x1324)
0°C	5700 (0x1644)
150°C	8700 (0x21FC)

**8.3.10.4 ADC Scan Mode**

The ADC is configured in auto scan mode, in which the ADC converts the pressure and temperature signals periodically.

**8.3.10.4.1 P-T Multiplexer Timing in Auto Scan Mode**

PGA302 has a multiplexer that multiplexes P and T channels into a single ADC. [Figure 12](#) shows the multiplexing scheme.

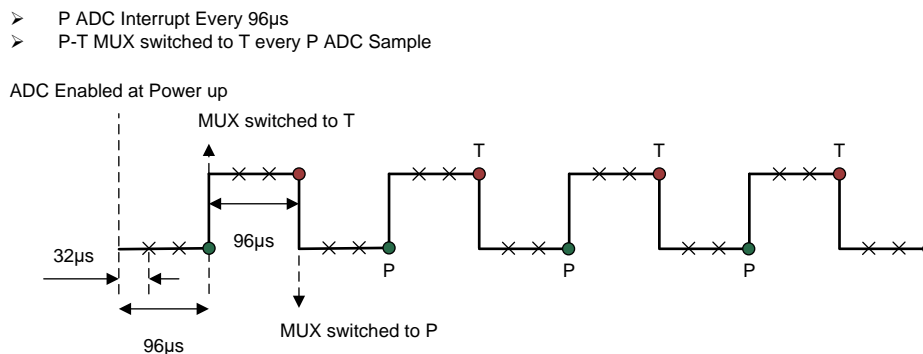
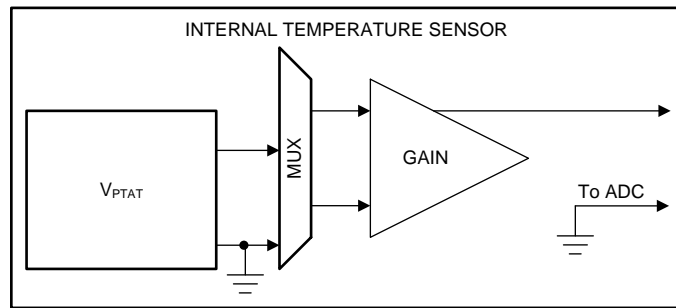

**Figure 12. P-T multiplexing**

**8.3.11 Internal Temperature Sensor**

PGA302 includes an internal temperature sensor whose voltage output is digitized by the ADC and made available to the processor. This digitized value is used to implement temperature compensation algorithms. Note that the voltage generated by the internal temperature sensor is proportional to the junction temperature.

Figure 13 shows the internal temperature sensor AFE.



Copyright © 2017, Texas Instruments Incorporated

Figure 13. Temperature Sensor AFE

### 8.3.12 Bridge Current Measurement

PGA302 includes a bridge current measurement scheme. This digitized value can be used to implement temperature compensation algorithms. Note that the voltage generated is proportional to the bridge current.

Figure 14 shows the bridge current AFE.

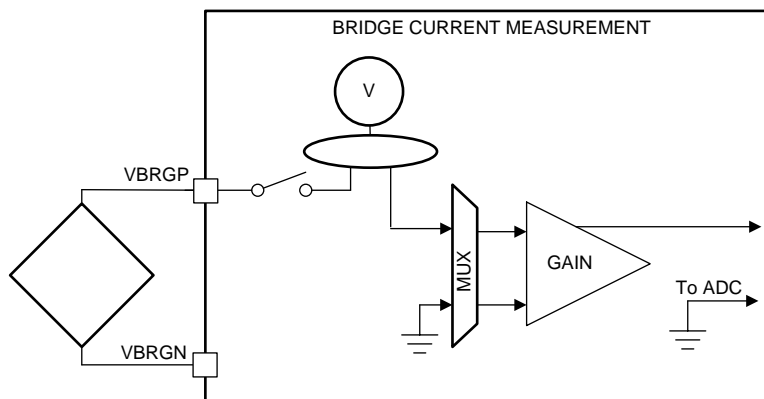

Copyright © 2017, Texas Instruments Incorporated

Figure 14. Bridge Current Measurement

### 8.3.13 Digital Interface

The digital interfaces are used to access (read and write) the internal memory spaces. The device has following modes of communication:

1. One-wire interface (OWI)

The communication modes supported by PGA302 are referred to as digital interface in this document. For communication modes, PGA302 device operates as a slave device.

### 8.3.14 OWI

The device includes a OWI digital communication interface. The function of OWI is to enable writes to and reads from all memory locations inside PGA302 available for OWI access.

#### 8.3.14.1 Overview of OWI Interface

The OWI digital communication is a master-slave communication link in which the PGA302 operates as a slave device only. The master device controls when data transmission begins and ends. The slave device does not transmit data back to the master until it is commanded to do so by the master.

The VDD pin of PGA302 is used as OWI interface, so that when PGA302 is embedded inside of a system module, only two pins are needed (VDD and GND) for communication. The OWI master communicates with PGA302 by modulating the voltage on VDD pin while PGA302 communicates with the master by modulating current on VDD pin. The PGA302 processor has the ability to control the activation and deactivation of the OWI interface based upon the OWI Activation pulse driven on VDD pin.

Figure 15 shows a functional equivalent circuit for the structure of the OWI circuitry.

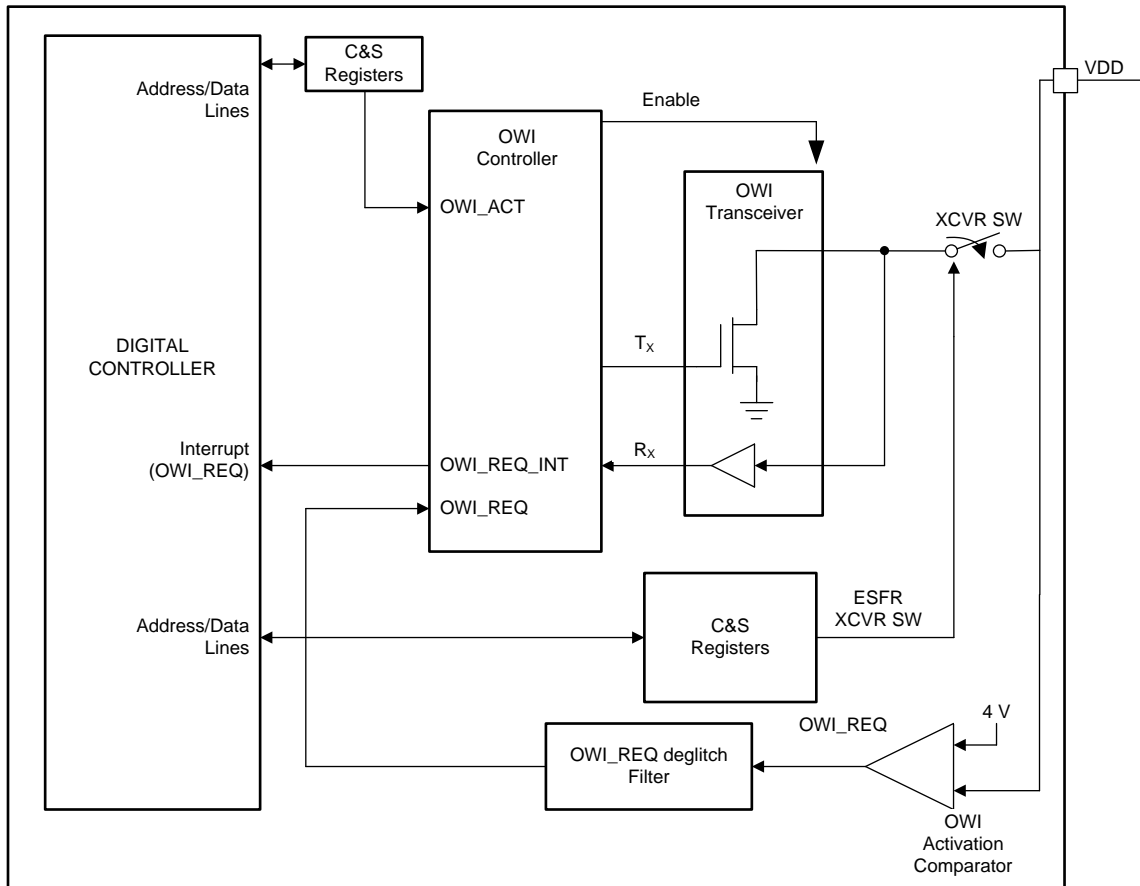

Copyright © 2017, Texas Instruments Incorporated

Figure 15. OWI System Components

### 8.3.14.2 Activating and Deactivating the OWI Interface

#### 8.3.14.2.1 Activating OWI Communication

The OWI master initiates OWI communication by generating **OWI Activation Pulse** on VDD pin. When PGA302 receives a valid OWI Activation pulse, it prepares itself for OWI communication.

To activate OWI communication, the OWI master must Generate an OWI Activation pulse on VDD pin. Figure 16 illustrates the OWI Activation Pulse that is generated by the Master.

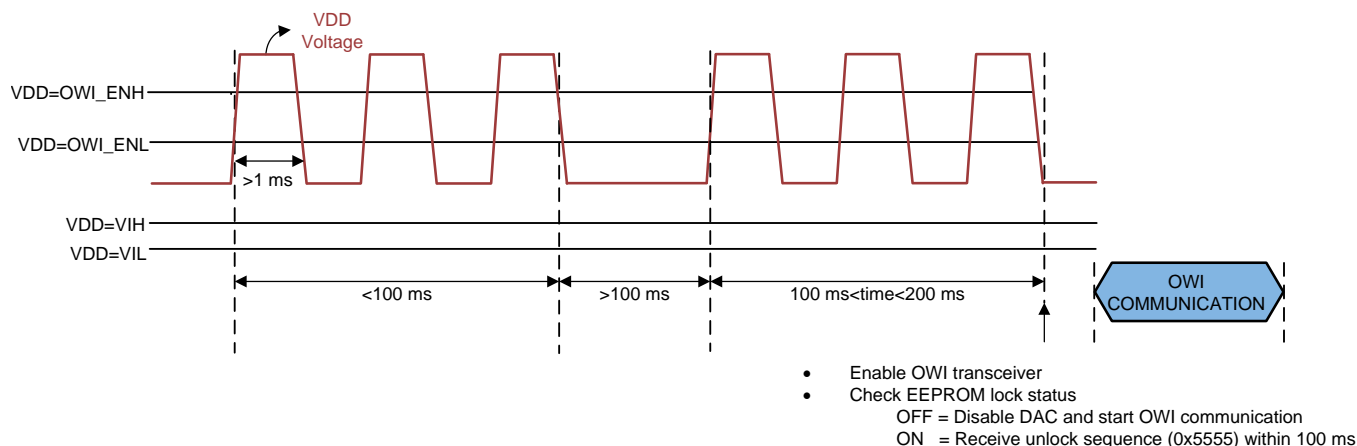

Figure 16. OWI Activation Using Overvoltage Drive

8.3.14.2.2 Deactivating OWI Communication

To deactivate OWI communication and restart the processor inside PGA302 (if it was in reset), the following step must be performed by the OWI Master

- The processor reset should be deasserted by writing 0 to MICRO\_RESET bit in MICRO\_INTERFCE\_CONTROL register and access to Digital Interface should be disabled by writing 0 to IF\_SEL bit in the MICRO\_INTERFACE\_CONTROL register.

8.3.14.3 OWI Protocol

8.3.14.3.1 OWI Frame Structure

8.3.14.3.1.1 Standard field structure:

Data is transmitted on the one-wire interface in byte sized packets. The first bit of the OWI field is the start bit. The next 8 bits of the field are data bits to be processed by the OWI control logic. The final bit in the OWI field is the stop bit. A group of fields make up a transmission frame. A transmission frame is composed of the fields necessary to complete one transmission operation on the one-wire interface. The standard field structure for a one-wire field is shown in Figure 17

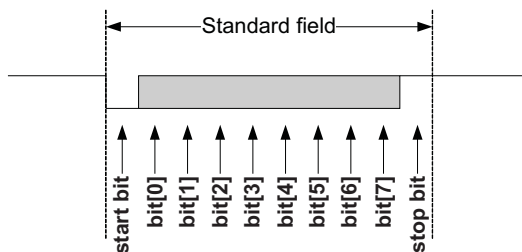
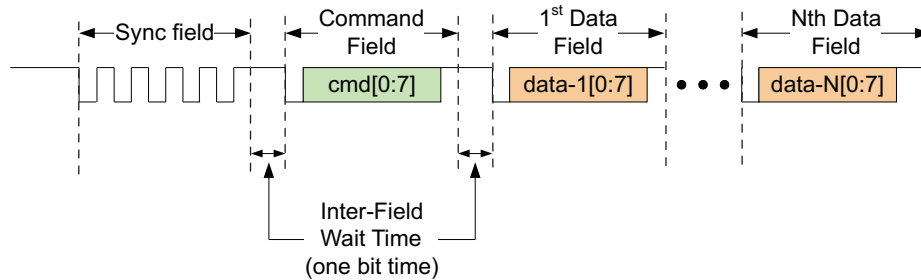

Figure 17. Standard OWI Field

### 8.3.14.3.1.2 Frame Structure

A complete one-wire data transmission operation is done in a frame with the structure is shown in [Figure 18](#).



**Figure 18. OWI Transmission Frame, N = 1 to 8**

Each transmission frame must have a Synchronization field and command field followed by zero to a maximum of 8 data fields. The sync field and command fields are always transmitted by the master device. The data field(s) may be transmitted either by the master or the slave depending on the command given in the command field. It is the command field which determines direction of travel of the data fields (master-to-slave or slave-to-master). The number of data fields transmitted is also determined by the command in the command field. The inter-field wait time is optional and may be necessary for the slave or the master to process data that has been received.

If OWI remains idle in either logic 0 or logic 1 state, for more than 15 ms, then the PGA302 communication will reset and will expect to receive a sync field as the next data transmission from the master.

### 8.3.14.3.1.3 Sync Field

The Sync field is the first field in every frame that is transmitted by the master. The Sync field is used by the slave device to compute the bit width transmitted by the master. This bit width will be used to accurately receive all subsequent fields transmitted by the master. The format of the Sync field is shown in [Figure 19](#).

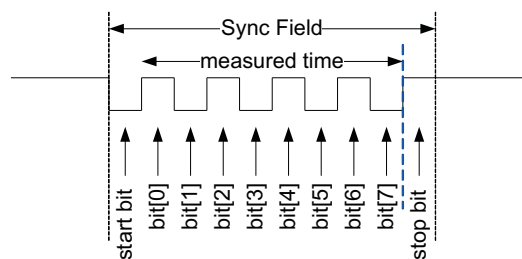

**Figure 19. The OWI Sync Field.**

#### NOTE

Consecutive SYNC field bits are measured and compared to determine if a valid SYNC field is being transmitted to the PGA302 is valid. If the difference in bit widths of any two consecutive SYNC field bits is greater than +/- 25%, then PGA302 will ignore the rest of the OWI frame (that is, the PGA302 will not respond to the OWI message).

### 8.3.14.3.1.4 Command Field

The command field is the second field in every frame sent by the master. The command field contains instructions about what to do with and where to send the data that is transmitted to the slave. The command field can also instruct the slave to send data back to the master during a Read operation. The number of data fields to be transmitted is also determined by the command in the command field. The format of the command field is shown in [Figure 20](#).



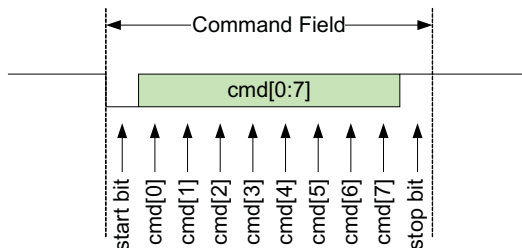

Figure 20. The OWI Command Field.

8.3.14.3.1.5 Data Field(s)

After the Master has transmitted the command field in the transmission frame, Zero or more Data Fields are transmitted to the slave (Write operation) or to the master (Read operation). The Data fields can be raw EEPROM data or address locations in which to store data. The format of the data is determined by the command in the command field. The typical format of a data field is shown in Figure 21.

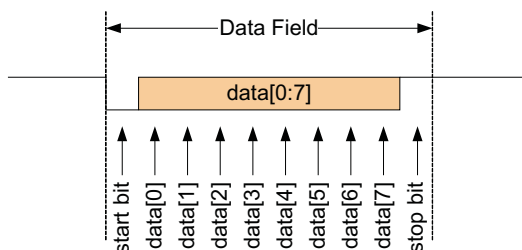

Figure 21. The OWI Data Field.

8.3.14.3.2 OWI Commands

The following is the list of five OWI commands supported by PGA302:

1. OWI Write
2. OWI Read Initialization
3. OWI Read Response
4. OWI Burst Write of EEPROM Cache
5. OWI Burst Read from EEPROM Cache

8.3.14.3.2.1 OWI Write Command

Field Location	Description	Bit 7	Bit 6	Bit 5	Bit 4	Bit 3	Bit 2	Bit 1	Bit 0
Command Field	Basic Write Command	0	P2	P1	P0	0	0	0	1
Data Field 1	Destination Address	A7	A6	A5	A4	A3	A2	A1	A0
Data Field 2	Data byte to be written	D7	D6	D5	D4	D3	D2	D1	D0

The P2, P1, P0 bits in the command field determine the memory page that is being accessed by the OWI. The memory page decode is shown in Table 4.

Table 4. OWI Memory Page Decode

P2	P1	P0	Memory Page
0	0	0	Control and Status Registers, DI_PAGE_ADDRESS = 0x00
0	1	0	Control and Status Registers, DI_PAGE_ADDRESS = 0x02
1	0	1	EEPROM Cache/Cells
1	1	0	Reserved

**Table 4. OWI Memory Page Decode (continued)**

P2	P1	P0	Memory Page
1	1	1	Control and Status Registers, DI_PAGE_ADDRESS = 0x07

**8.3.14.3.2.2 OWI Read Initialization Command**

Field Location	Description	Bit 7	Bit 6	Bit 5	Bit 4	Bit 3	Bit 2	Bit 1	Bit 0
Command Field	Read Init Command	0	P2	P1	P0	0	0	1	0
Data Field 1	Fetch Address	A7	A6	A5	A4	A3	A2	A1	A0

The P2, P1, P0 bits in the command field determine the memory page that is being accessed by the OWI. The memory page decode is shown in [Table 4](#).

**8.3.14.3.2.3 OWI Read Response Command**

Field Location	Description	Bit 7	Bit 6	Bit 5	Bit 4	Bit 3	Bit 2	Bit 1	Bit 0
Command Field	Read Response Command	0	1	1	1	0	0	1	1
Data Field 1	Data Retrieved (OWI drives data out)	D7	D6	D5	D4	D3	D2	D1	D0

The P2, P1, P0 bits in the command field determine the memory page that is being accessed by the OWI. The memory page decode is shown in [Table 4](#).

**8.3.14.3.2.4 OWI Burst Write Command (EEPROM Cache Access)**

Field Location	Description	Bit 7	Bit 6	Bit 5	Bit 4	Bit 3	Bit 2	Bit 1	Bit 0
Command Field	EE_CACHE Write Command Cache Bytes (0–7)	1	1	0	1	0	0	0	0
Data Field 1	1st Data Byte to be written	D7	D6	D5	D4	D3	D2	D1	D0
Data Field 2	2nd Data Byte to be written	D7	D6	D5	D4	D3	D2	D1	D0

**8.3.14.3.2.5 OWI Burst Read Command (EEPROM Cache Access)**

Field Location	Description	Bit 7	Bit 6	Bit 5	Bit 4	Bit 3	Bit 2	Bit 1	Bit 0
Command Field	Burst read Response (8- bytes)	1	1	0	1	0	0	1	1
Data Field 1	1st Data Byte Retrieved EE Cache Byte 0	D7	D6	D5	D4	D3	D2	D1	D0
Data Field 2	2nd Data Byte Retrieved EE Cache Byte 1	D7	D6	D5	D4	D3	D2	D1	D0

**8.3.14.3.3 OWI Operations**
**8.3.14.3.3.1 Write Operation**

The write operation on the one-wire interface is fairly straightforward. The command field specifies the write operation, where the subsequent data bytes are to be stored in the slave, and how many data fields are going to be sent. Additional command instructions can be sent in the first few data fields if necessary. The write operation is illustrated in [Figure 22](#).

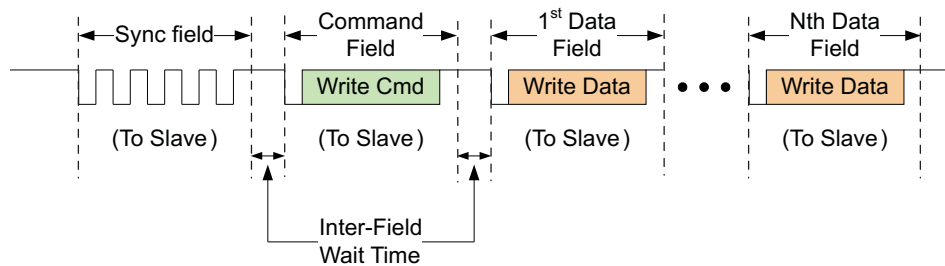

Figure 22. Write Operation, N = 1 to 8.

8.3.14.3.3.2 Read Operation

The read operation requires two consecutive transmission frames to move data from the slave to the master. The first frame is the Read Initialization Frame. It tells the slave to retrieve data from a particular location within the slave device and prepare to send it over the OWI. The data location may be specified in the command field or may require additional data fields for complete data location specification. The data will not be sent until the master commands it to be sent in the subsequent frame called the Read Response Frame. During the read response frame the data direction changes from master → slave to slave → master right after the read response command field is sent. Enough time exist between the command field and data field in order to allow the signal drivers time to change direction. This wait time is 20 μs and the timer for this wait time is located on the slave device. After this wait time is complete the slave will transmit the requested data. The master device is expected to have switched its signal drivers and is ready to receive data. The Read frames are shown in Figure 23.

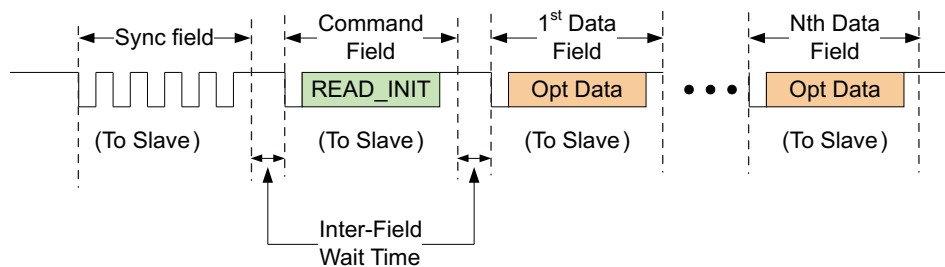

Figure 23. Read Initialization Frame, N = 1 to 8.

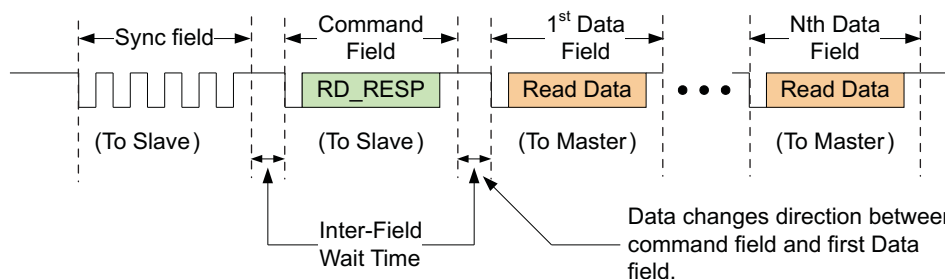

Figure 24. Read Response Frame, N = 1 to 8

8.3.14.3.3.3 EEPROM Burst Write

The EEPROM burst write is used to write 2 bytes of data to the EEPROM Cache using one OWI frame. This allows fast programming of EEPROM in the manufacturing line. Note that the EEPROM page has to be selected before transferring the contents of the EEPROM memory cells to the EEPROM cache.

8.3.14.3.3.4 EEPROM Burst Read

The EEPROM burst read is used to read 2 bytes of data from the EEPROM Cache using one OWI frame. The Burst Read command is used for fast read the EEPROM cache contents in the manufacturing line. The read process is used to verify the writes to the EEPROM cache.

### 8.3.14.4 OWI Communication Error Status

PGA302 detects errors in OWI communication. OWI\_ERROR\_STATUS\_LO and OWI\_ERROR\_STATUS\_HI registers contain OWI communication error bits. The communication errors detected include:

- Out of range communication baud rate
- Invalid SYNC field
- Invalid STOP bits in command and data
- Invalid OWI command

### 8.3.15 I<sup>2</sup>C Interface

The device includes an Inter-Integrated Circuit (I<sup>2</sup>C) digital communication interface. The main function of the I<sup>2</sup>C is to enable writes to, and reads from, all addresses available for I<sup>2</sup>C access.

#### 8.3.15.1 Overview of I<sup>2</sup>C Interface

I<sup>2</sup>C is a synchronous serial communication standard that requires the following two pins for communication:

- SDA: I<sup>2</sup>C Serial Data Line (SDA)
- SCL: I<sup>2</sup>C Serial Clock Line (SCL)

I<sup>2</sup>C communicates in a master/slave style communication bus where one device, the master, can initiate data transmission. The device always acts as the slave device in I<sup>2</sup>C communication, where the external device that is communicating to it acts as the master node. The master device is responsible for initiating communication over the SDA line and supplying the clock signal on the SCL line. When the I<sup>2</sup>C SDA line is pulled low it is considered a logical zero, and when the I<sup>2</sup>C SDA line is floating high it is considered a logical one. For the I<sup>2</sup>C interface to have access to memory locations other than test register space, the IF\_SEL bit in the Micro/Interface Control Test register (MICRO\_IF\_SEL\_T) has to be set to logic one.

#### 8.3.15.2 I<sup>2</sup>C Interface Protocol

The basic Protocol of the I<sup>2</sup>C frame for a Write operation is shown in [Figure 25](#):

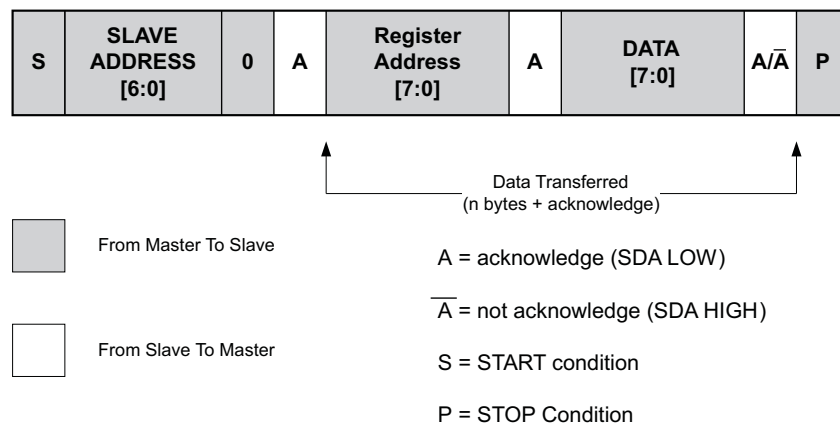

**Figure 25. I<sup>2</sup>C Write Operation: A Master-Transmitter Addressing a PGA302 Slave With a 7-Bit Slave Address**

The diagram represents the data fed into or out from the I<sup>2</sup>C SDA port.

The basic data transfer is to send 2 bytes of data to the specified Slave Address. The first data field is the register address and the second data field is the data sent or received.

The I<sup>2</sup>C Slave Address is used to determine which memory page is being referenced. [Table 5](#) shows the mapping of the slave address to the memory page.

**Table 5. Slave Addresses**

Slave Address	PGA302 Memory Page
0x40	Test Registers
0x42	Control and Status Registers, DI_PAGE_ADDRESS = 0x02
0x45	EEPROM Cache/Cells
0x46	Reserved
0x47	Control and Status Registers, DI_PAGE_ADDRESS = 0x07

The basic PGA302 I<sup>2</sup>C Protocol for a read operation is shown in Figure 26.

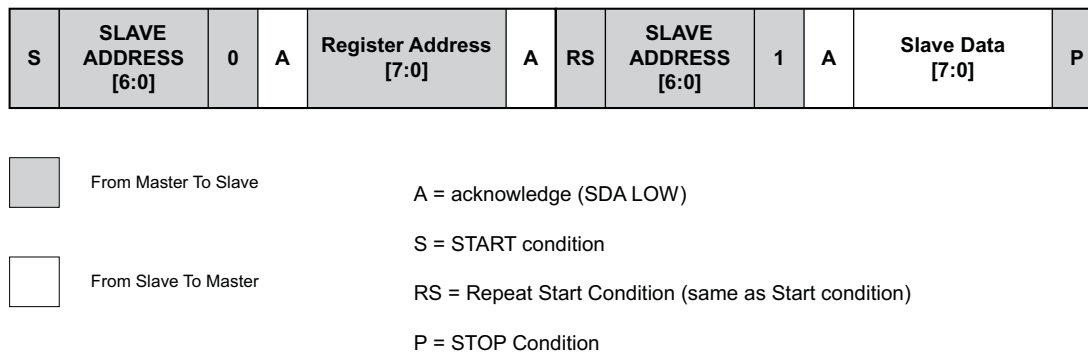

**Figure 26. I<sup>2</sup>C Read Operation: A Master-Transmitter Addressing a PGA302 Slave With a 7-Bit Slave Address**

The Slave Address determines the memory page. The R/W bit is set to 0.

The Register Address specifies the 8-bit address of the requested data.

The Repeat Start Condition replaces the write data from the above write operation description. This informs the PGA302 devices that Read operation will take place instead of a write operation.

The second Slave Address contains the memory page from which the data will be retrieved. The R/W bit is set to 1.

Slave data is transmitted after the acknowledge is received by the master.

Table 6 lists a few examples of I2C Transfers.

**Table 6. I2C Transfers Examples**

Command	Master to Slave Data on I2C SDA
Read COM_MCU_TO_DIF_B0	Slave Address: 100 0000 Register Address: 0000 0100
Write 0x80 to Control and Status Registers 0x30 (DAC_REG0_1)	Slave Address: 100 0010 Register Address: 0011 0000 Data: 1000 0000
Read from EEPROM Byte 7	Slave Address: 100 0101 Register Address: 0000 0111

**8.3.15.3 Clocking Details of I<sup>2</sup>C Interface**

The device samples the data on the SDA line when the rising edge of the SCL line is high, and is changed when the SCL line is low. The only exceptions to this indication are start, stop, or repeated start conditions as shown in Figure 27.

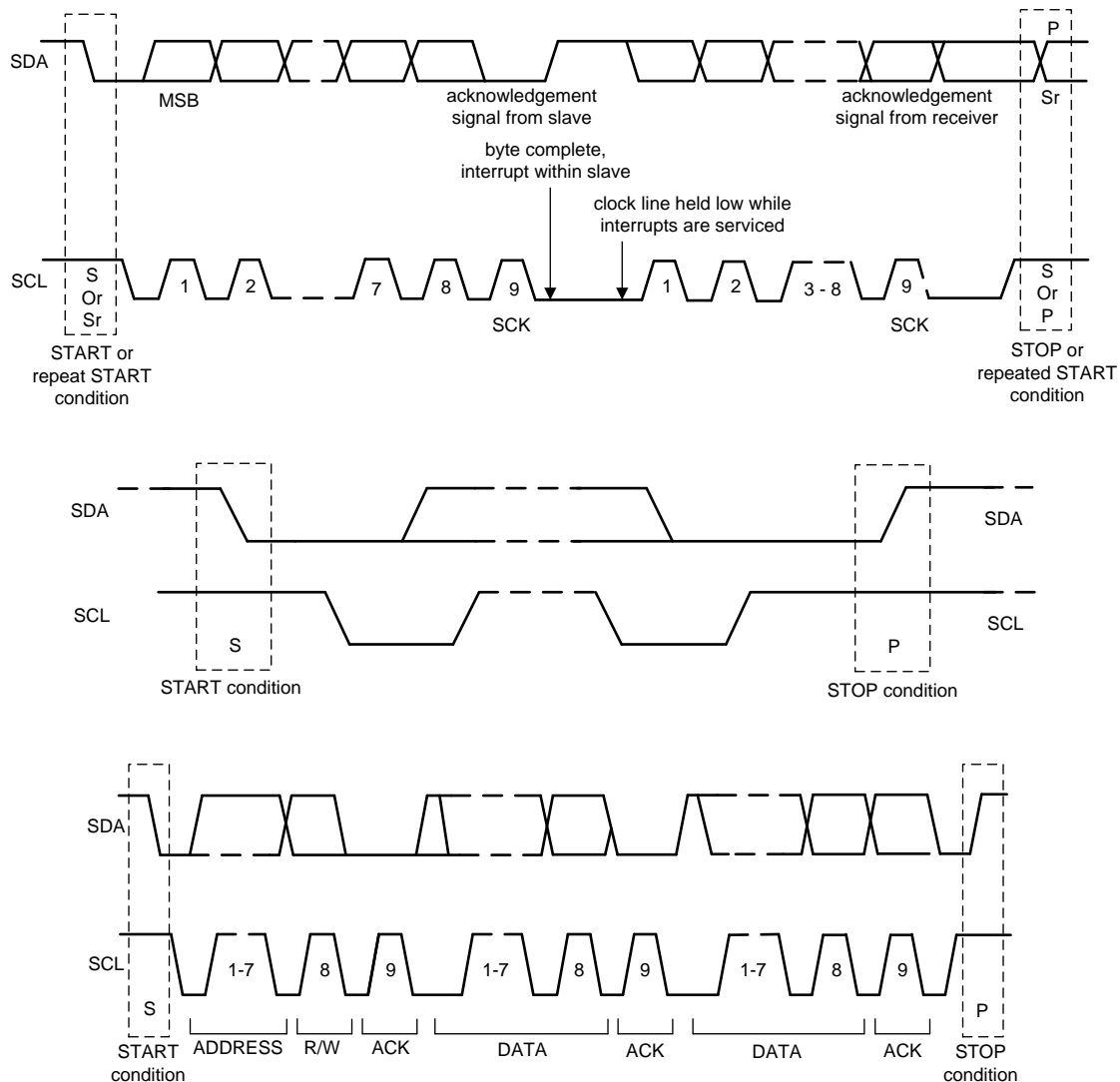

Figure 27. I2C Clocking Details

### 8.3.16 DAC Output

The device includes a 14-bit digital to analog converter that produces ratiometric output voltage with respect to the VDD supply. The DAC can be disabled by writing 0 to DAC\_ENABLE bit in DAC\_CTRL\_STATUS register.

When the processor undergoes a reset, the DAC registers are driven to 0x000 code.

### 8.3.17 DAC Gain for DAC Output

The DAC Gain buffer is a buffer stage for the DAC Output. The final stage of DAC Gain is connected to VDDp and Ground. This gives the ability to drive VOUT voltage close to VDD voltage.

#### 8.3.17.1 Connecting DAC Output to DAC GAIN Input

The DAC output can either be connected to TEST1 test pin or can be connected to DAC GAIN input as shown in Figure 28. Note that DAC output can be connected to DAC GAIN input by setting TEMP\_MUX\_DAC\_EN bit in AMUX\_CTRL register to 1.

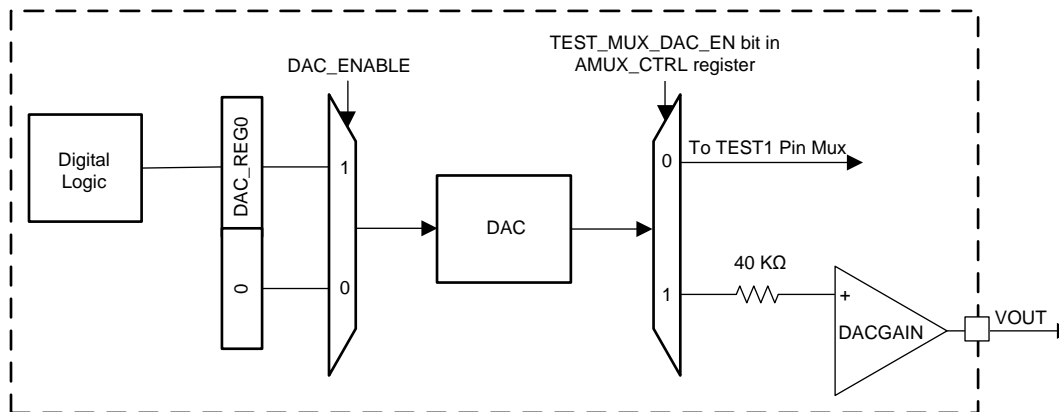

Copyright © 2017, Texas Instruments Incorporated

Figure 28. Connecting DAC to DAC GAIN

### 8.3.18 Memory

#### 8.3.18.1 EEPROM Memory

Figure 29 shows the EEPROM structure. The contents of each EEPROM must be transferred to the EEPROM Cache before writes (that is, the EEPROM can be programmed 2 bytes at a time). The EEPROM reads occur without the EEPROM cache.

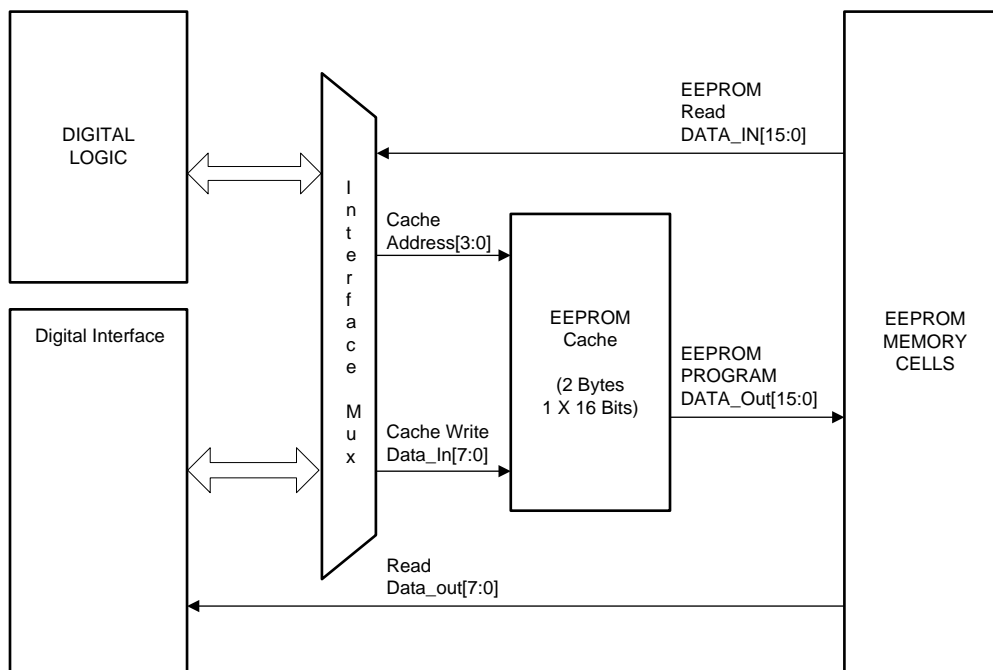

Copyright © 2017, Texas Instruments Incorporated

Figure 29. Structure of EEPROM Interface

##### 8.3.18.1.1 EEPROM Cache

The EEPROM Cache serves as temporary storage of data being transferred to selected EEPROM locations during the programming process.

### 8.3.18.1.2 EEPROM Programming Procedure

For programming the EEPROM, the EEPROM is organized in 64 pages of 2 bytes each. The EEPROM memory cells are programmed by writing to the 2-byte EEPROM Cache. The contents of the cache are transferred to EEPROM memory cells by selecting the EEPROM memory page.

1. Select the EEPROM page by writing the upper 6 bits of the 7-bit EEPROM address to EEPROM\_PAGE\_ADDRESS register
2. Load the 2-byte EEPROM Cache by writing to the EEPROM\_CACHE registers.
3. User can erase by writing 1 to the ERASE bit in EEPROM\_CTRL register and 1 to the PROGAM bit in the EEPROM\_CTRL register simultaneously.

### 8.3.18.1.3 EEPROM Programming Current

The EEPROM programming process will result in an additional 1.5-mA current on the VDD pin for the duration of programming.

### 8.3.18.1.4 CRC

The last byte of the EEPROM memory is reserved for the CRC. This CRC value covers all data in the EEPROM memory. Every time the last byte is programmed, the CRC value is automatically calculated and validated. The validation process checks the calculated CRC value with the last byte programmed in the EEPROM memory cell. If the calculated CRC matches the value programmed in the last byte, the CRC\_GOOD bit is set in EEPROM\_CRC\_STATUS register.

The CRC check can also be initiated at any time by setting the CALCULATE\_CRC bit in the EEPROM\_CRC register. The status of the CRC calculation is available in CRC\_CHECK\_IN\_PROG bit in EEPROM\_CRC\_STATUS register, while the result of the CRC validation is available in CRC\_GOOD bit in EEPROM\_CRC\_STATUS register.

The CRC calculation pseudo code is as follows:

```

currentCRC8 = 0xFF; // Current value of CRC8

for NextData
  D = NextData;
  C = currentCRC8;

  begin
    nextCRC8_BIT0 = D_BIT7 ^ D_BIT6 ^ D_BIT0 ^ C_BIT0 ^ C_BIT6 ^ C_BIT7;
    nextCRC8_BIT1 = D_BIT6 ^ D_BIT1 ^ D_BIT0 ^ C_BIT0 ^ C_BIT1 ^ C_BIT6;
    nextCRC8_BIT2 = D_BIT6 ^ D_BIT2 ^ D_BIT1 ^ D_BIT0 ^ C_BIT0 ^ C_BIT1 ^ C_BIT2 ^ C_BIT6;
    nextCRC8_BIT3 = D_BIT7 ^ D_BIT3 ^ D_BIT2 ^ D_BIT1 ^ C_BIT1 ^ C_BIT2 ^ C_BIT3 ^ C_BIT7;
    nextCRC8_BIT4 = D_BIT4 ^ D_BIT3 ^ D_BIT2 ^ C_BIT2 ^ C_BIT3 ^ C_BIT4;
    nextCRC8_BIT5 = D_BIT5 ^ D_BIT4 ^ D_BIT3 ^ C_BIT3 ^ C_BIT4 ^ C_BIT5;
    nextCRC8_BIT6 = D_BIT6 ^ D_BIT5 ^ D_BIT4 ^ C_BIT4 ^ C_BIT5 ^ C_BIT6;
    nextCRC8_BIT7 = D_BIT7 ^ D_BIT6 ^ D_BIT5 ^ C_BIT5 ^ C_BIT6 ^ C_BIT7;

  end

  currentCRC8 = nextCRC8_D8;
endfor
  
```

---

#### NOTE

The EEPROM CRC calculation is complete 340  $\mu$ s after digital core starts running at power up.

---



### 8.3.19 Diagnostics

This section describes the diagnostics.

#### 8.3.19.1 Power Supply Diagnostics

The device includes modules to monitor the power supply for faults. The internal power rails that are monitored are:

1. VDD Voltage, thresholds are generated using High Voltage Reference
2. DVDD Voltage, thresholds are generated using High Voltage Reference
3. Bridge Supply Voltage, thresholds are generated using High Voltage Reference
4. Internal Oscillator Supply Voltage, thresholds are generated using High Voltage Reference
5. Reference Output Voltage, thresholds are generated using High Voltage Reference

The electrical specifications lists the voltage thresholds for each of power rails.

#### 8.3.19.2 Sensor Connectivity/Gain Input Faults

The device includes circuits to monitor bridge connectivity and temperature sensor connectivity fault. Note that temperature sensor connectivity fault is monitored only in 16-pin package option. Specifically, the device monitors the bridge pins for opens (including loss of connection from the sensor), short-to-ground, and short-to-sensor supply.

**Table 7. Sensor Connectivity/Gain Input Faults (Diagnostic Resistors Active)**

Fault No.	Fault Mode	Chip Behavior
1	VBRGP Open	VINP_UV and PGAIN_UV flags set
2	VBRGN Open	N/A
3	VINPP Open	VINP_UV and PGAIN_UV flags set
4	VINPN Open	VINP_UV and PGAIN_UV flags set
5	VBRGP Shorted to VBRGN	VBRG_UV, VINP_UV and PGAIN_UV flags set
6	VBRGP Shorted to VINPP	VINP_OV and PGAIN_OV flags set
7	VBRGP Shorted to VINPN	VINP_OV and PGAIN_OV flags set
8	VINPP shorted to VINPN	N/A
9	VINNPP shorted to VBRGN	VINP_UV and PGAIN_UV flags set
10	Temperature path is differential, VINTP Open	TGAIN_UV flag set
11	Temperature path is differential, VINTN Open	VINT_OV and TGAIN_OV flags set
12	Temperature path is differential, VINTP shorted to VINTN	N/A
13	Temperature path is single-ended, VINTP Open	TGAIN_UV flag set
14	Temperature path is single-ended, VINTN Shorted to ground	TGAIN_UV flag set

The thresholds for connectivity fault are derived off of VBRDG voltage.

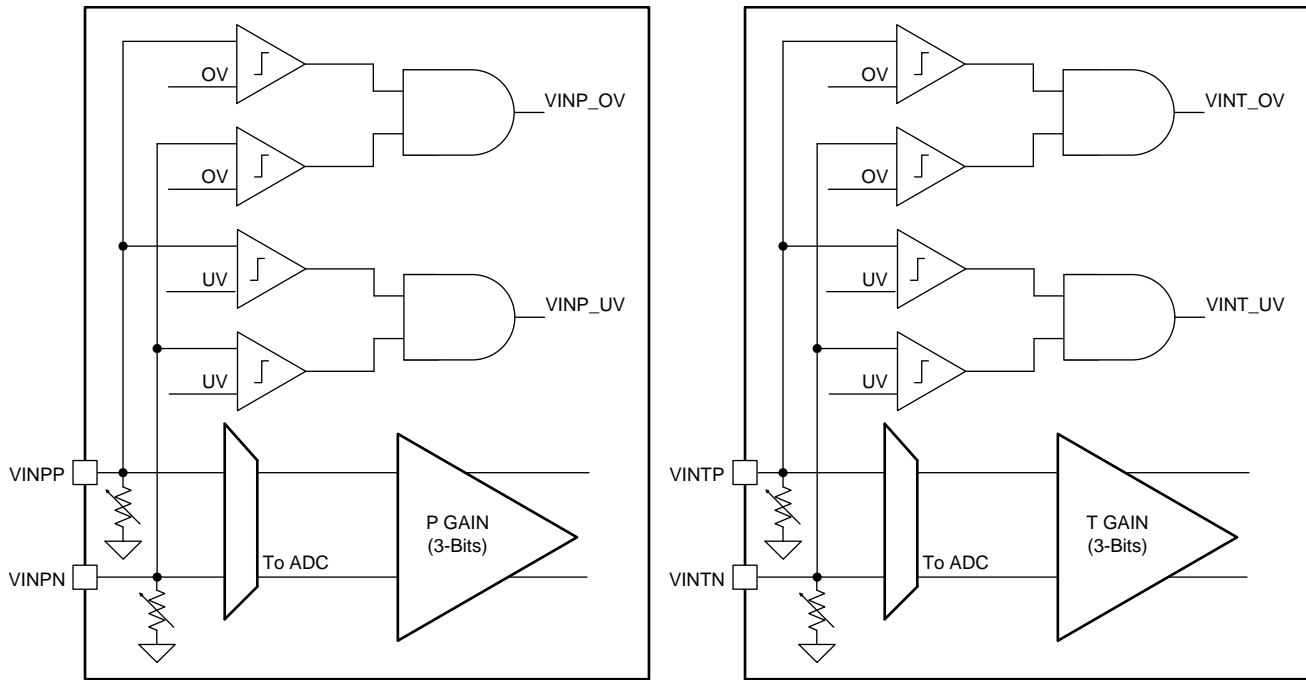

Copyright © 2017, Texas Instruments Incorporated

Figure 30. Block Diagram of Bridge Connectivity Diagnostics

### 8.3.19.3 Gain Output Diagnostics

The device includes modules that verify that the output signal of each gain is within a certain range. This ensures that gain stages in the signal chain are working correctly. AVDD voltage is used to generate the threshold voltages for comparison.

When a fault is detected, the corresponding bit in AFEDIAG register is set. Even after the faulty condition is removed, the fault bits will remain latched. To remove the fault, M0 software should read the fault bit and write a logic zero back to the bit. A system reset will clear the fault.

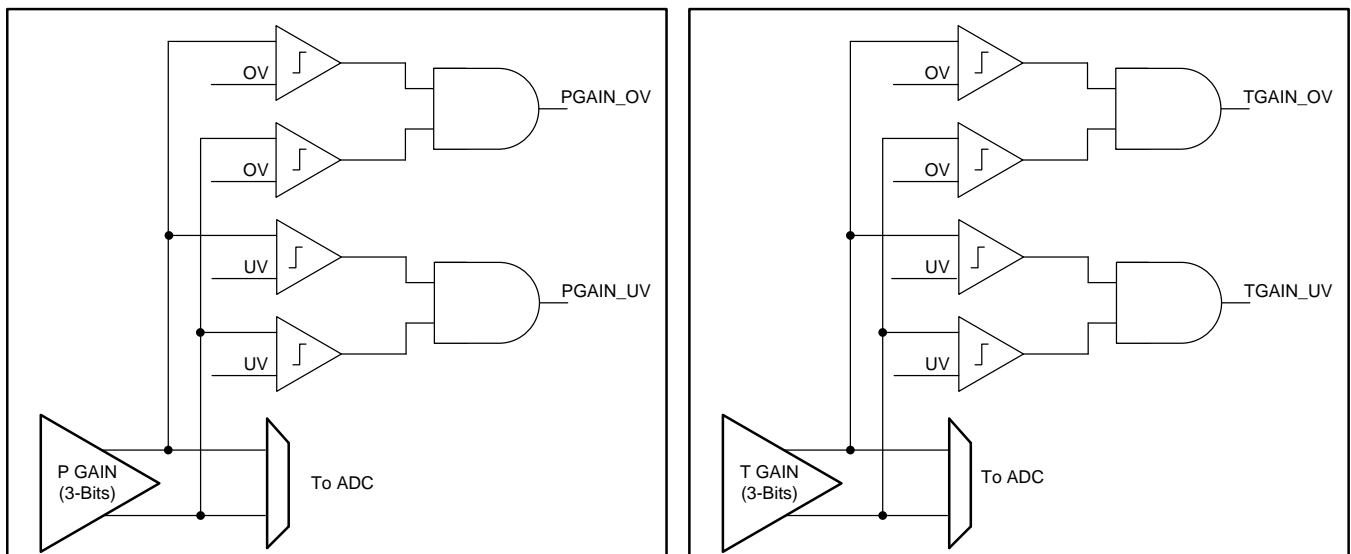

Copyright © 2017, Texas Instruments Incorporated

Figure 31. Block Diagram of Gain Output Diagnostics

### 8.3.19.4 PGA302 Harness Open Wire Diagnostics

PGA302 allows for Open Wire Diagnostics to be performed in the ECU. Specifically, the ECU can detect open VDD or Open GND wire by installing a pullup or pulldown on VOUT line.

**Table 8. PGA302 Harness Faults**

Fault No.	Device VDD	Device GND	Device VOUT	Remark	Device status after removal of failure
1	5 V	0 V	Pullup to VDD	Normal Connection with VOUT to Pulled to VDD	Resumes normal operation
2	5 V	0 V	Pulldown to GND	Normal Connection with VOUT to Pulled to GND	Device Reset
3	20 V	0 V	GND to VDD	Overvoltage	Device Reset
4	Open	0 V	Pullup to VDD = 5 V	Open VDD with VOUT Pulled to VDD	Device Reset
5	Open	0 V	Pulldown to GND	Open VDD with VOUT Pulled to GND	Device Reset
6	5 V	Open	Pullup to VDD = 5 V	Open GND with VOUT Pulled to VDD	Device Reset
7	5 V	Open	Pulldown to GND	Open GND with VOUT Pulled to GND	Device Reset
8	0 V	20 V	Pullup to VDD	Reverse Voltage with VOUT Pulled to VDD	Device Reset
9	0 V	20 V	Pulldown to GND	Reverse Voltage with VOUT Puledl to GND	Physical Damage possible.
10	0 V	0 V	Pullup to VDD	VDD Shorted to GND with VOUT Pulled to VDD	Device Reset
11	0 V	0 V	Pulldown to GND	VDD Shorted to GND with VOUT Pulled to GND	Device Reset
12	20 V	20 V	Pullup to VDD	GND Shorted to VDD with VOUT Pulled to VDD	Device Reset. Physical Damage possible.
13	20 V	20 V	Pulldown to GND	GND Shorted to VDD with VOUT Pulled to GND	Device Reset
14	20 V	0 V	20 V	VOUT Shorted to VDD	Device Reset. Physical Damage possible.
15	20 V	0 V	0 V	VOUT Shorted to GND	Resumes normal operation

Figure 32 shows the possible harness open wire faults on VDD and GND pins.

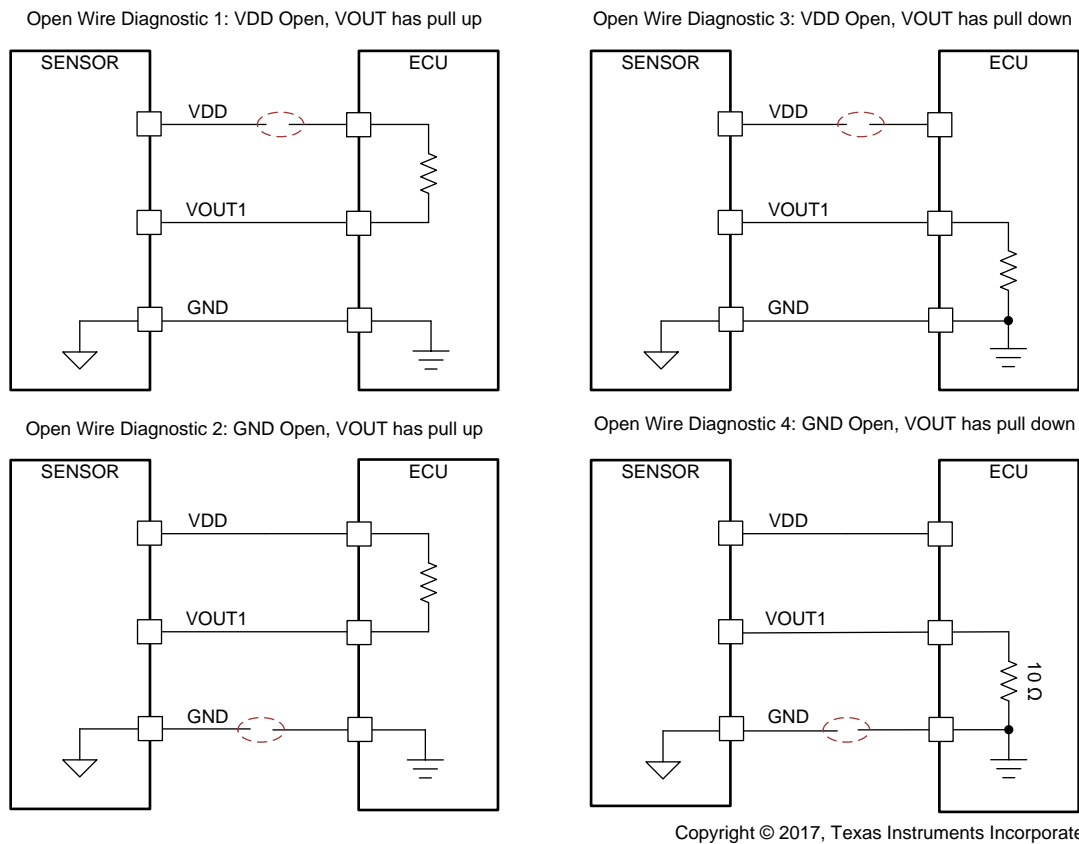

Figure 32. Harness Open Wire Diagnostics

Table 9 summarizes the open wire diagnostics and the corresponding resistor pull values that allows the ECU to detect open harness faults.

Table 9. Typical Internal Pulldown Settings

Open Harness	ECU Pull Direction	Max Pull Value (KΩ)	State of PGA302 during fault condition	ECU Voltage Level (VOUT/OWI pin)
VDD	Pullup	50	PGA302 is off. Leakage currents present (especially at high temp)	$VDD - (I_{leak1} \times R_{pullup})$
GND	Pullup	N/A	PGA302 is off, all power rails pulled up to VDD	VDD
VDD	Pulldown	N/A	PGA302 is off, all power rails pulled down to ground	GND
GND	Pulldown	50	PGA302 is off, leakage current pushed into VOUT pin (thru the chip's ground).	$GND + (I_{leak2} \times R_{pulldown})$

### 8.3.19.5 EEPROM CRC and TRIM Error

The last Byte in the EEPROM stores the CRC for all the data in EEPROM.

The user can verify the EEPROM CRC at any time. When the last byte is programmed into the EEPROM, the device automatically calculates the CRC and updates the CRC\_GOOD bit in EEPROM CRC Status Register. The validity of the CRC can also be verified by initiating the CRC check by setting the control bit CACULATE\_CRC bit in EEPROM\_CRC register.

The device also has analog trim values. The validity of the analog trim values is checked on power up. The validity of the trim values can be inferred using the CRC\_GOOD bit in the TRIM\_CRC\_STATUS register.

### 8.3.20 Digital Compensation and Filter

PGA300 implements a second order TC and NL correction of the pressure input. The corrected output is then filtered using a second order IIR filter and then written to the output register.

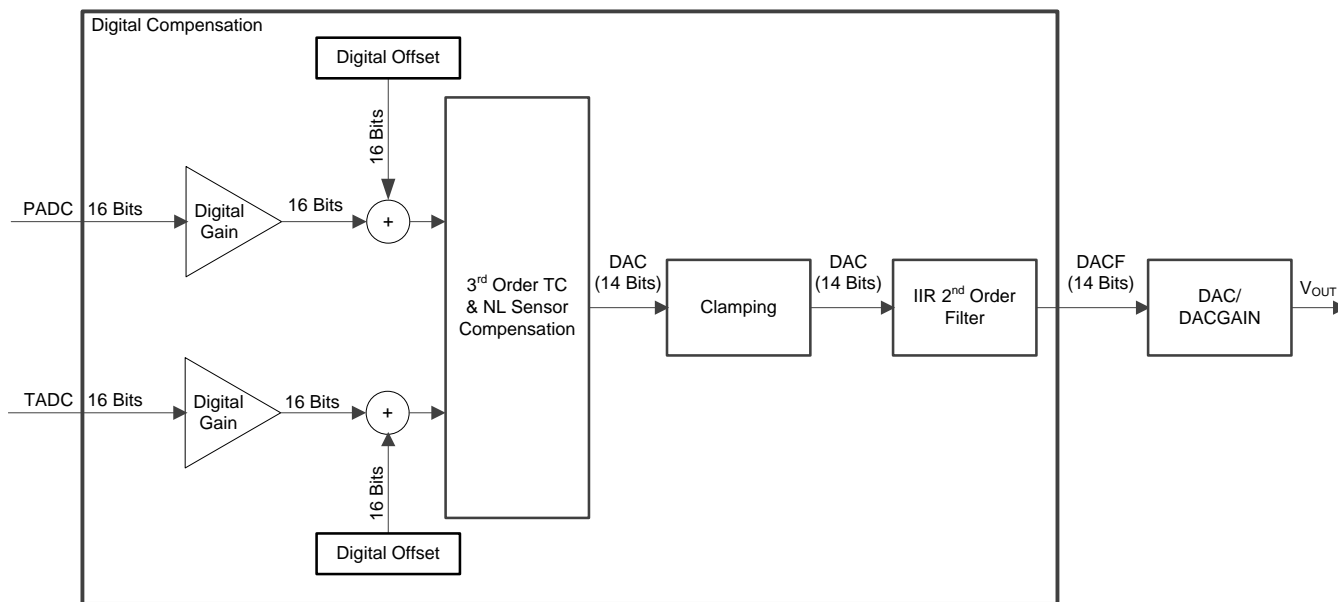

Copyright © 2017, Texas Instruments Incorporated

Figure 33. Digital Compensation Equation

#### 8.3.20.1 Digital Gain and Offset

The digital compensation implements digital gain and offset shown in Equation 2 and Equation 3:

$$P = a_0(PADC + b_0)$$

where

- $a_0$  is the digital gain
- and  $b_0$  is the digital offset for PADC

$$T = a_1(TADC + b_1)$$

where

- $a_1$  is the digital gain
- and  $b_1$  is the digital offset for TADC.

#### 8.3.20.2 TC and NL Correction

The compensation is shown in Equation 4:

$$\text{OUTPUT} = (h_0 + h_1 \times T + h_2 \times T^2 + h_3 \times T^3) + (g_0 + g_1 \times T + g_2 \times T^2 + g_3 \times T^3) \times P + (n_0 + n_1 \times T + n_2 \times T^2 + n_3 \times T^3) \times P^2 + (m_0 + m_1 \times T + m_2 \times T^2 + m_3 \times T^3) \times P^3 \quad (4)$$

### 8.3.20.3 Clamping

The output of the compensation is clamped. The low and high clamp values are programmable.

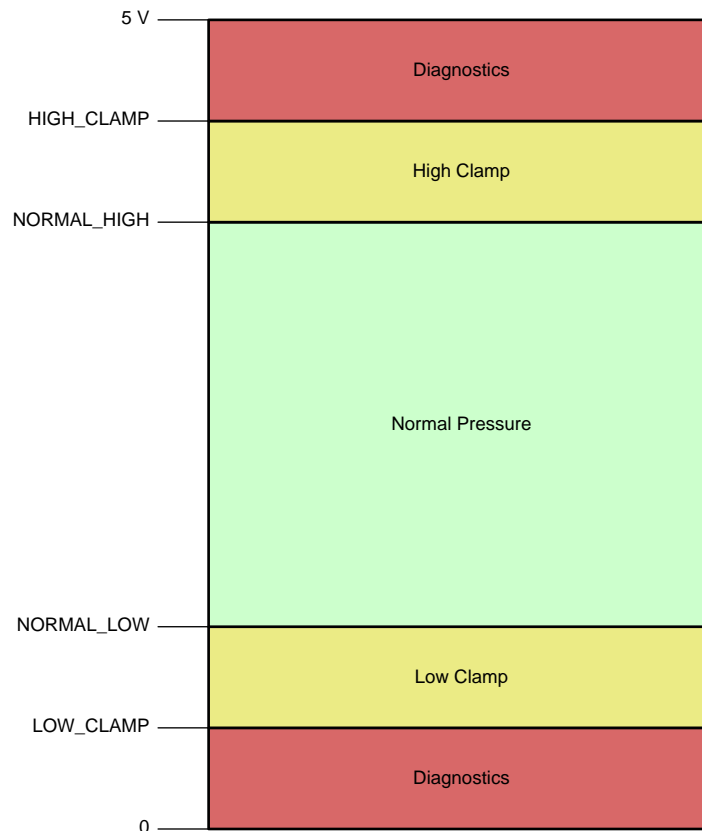

**Figure 34. PGA302 Clamping of Output**

### 8.3.20.4 Filter

The IIR filter is shown in [Equation 5](#) and [Equation 6](#):

$$w(n) = (a_0 \times \text{OUTPUT}(n) + a_1 \times w(n - 1) + a_2 w(n - 2)) \quad (5)$$

$$\text{OUTPUT\_FF}(n) = (b_0 \times w(n) + b_1 \times w(n - 1) + b_2 w(n - 2)) \quad (6)$$

### 8.3.21 Revision ID

PGA302 includes Revision ID registers. These registers are read-only and represent the device revision and is not unique for every device in a certain revision.

## 8.4 Device Functional Modes

There are two functional modes in the PGA302: A *Running* mode of operation where the digital processing logic is enabled and the *Reset* mode where the digital processing logic is in reset.

In the Running mode, the I2C and OWI digital interfaces are not allowed to access the PGA302 device memory space. The only communication with the device can be established by accessing the COMBUF communication buffer registers.

The Reset mode is generally used for PGA302 device configuration. In this mode, the I<sup>2</sup>C or OWI interfaces are allowed to read and write to the device memory. In this mode, the digital processing logic is in reset which means that no device internal signal processing is performed therefore no output data is being generated from the device itself.

## 8.5 Register Maps

### 8.5.1 Programmer's Model

#### 8.5.1.1 Memory Map

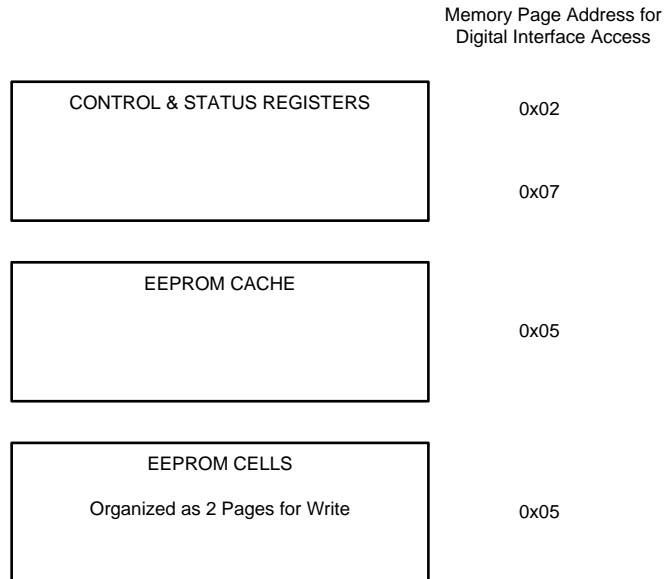

**Figure 35. Memory Map**

**8.5.1.2 Control and Status Registers**
**Table 10. PGA302 Control and Status Registers**

Register Name	DI Page Address	DI Offset Address	EEPROM Address	R/W	D7	D6	D5	D4	D3	D2	D1	D0
H0_LSB	N/A	N/A	0x40000000	RW	H0 [7:0]							
H0_MSB	N/A	N/A	0x40000001	RW	H0 [15:8]							
H1_LSB	N/A	N/A	0x40000002	RW	H1 [7:0]							
H1_MSB	N/A	N/A	0x40000003	RW	H1 [15:8]							
H2_LSB	N/A	N/A	0x40000004	RW	H2 [7:0]							
H2_MSB	N/A	N/A	0x40000005	RW	H2 [15:8]							
H3_LSB	N/A	N/A	0x40000006	RW	H3 [7:0]							
H3_MSB	N/A	N/A	0x40000007	RW	H3 [15:8]							
G0_LSB	N/A	N/A	0x40000008	RW	G0 [7:0]							
G0_MSB	N/A	N/A	0x40000009	RW	G0 [15:8]							
G1_LSB	N/A	N/A	0x4000000A	RW	G1 [7:0]							
G1_MSB	N/A	N/A	0x4000000B	RW	G1 [15:8]							
G2_LSB	N/A	N/A	0x4000000C	RW	G2 [7:0]							
G2_MSB	N/A	N/A	0x4000000D	RW	G2 [15:8]							
G3_LSB	N/A	N/A	0x4000003E	RW	G3 [7:0]							
G3_MSB	N/A	N/A	0x4000003F	RW	G3 [15:8]							
N0_LSB	N/A	N/A	0x40000010	RW	N0 [7:0]							
N0_MSB	N/A	N/A	0x40000011	RW	N0 [15:8]							
N1_LSB	N/A	N/A	0x40000012	RW	N1 [7:0]							
N1_MSB	N/A	N/A	0x40000013	RW	N1 [15:8]							
N2_LSB	N/A	N/A	0x40000014	RW	N2 [7:0]							
N2_MSB	N/A	N/A	0x40000015	RW	N2 [15:8]							
N3_LSB	N/A	N/A	0x40000016	RW	N3 [7:0]							
N3_MSB	N/A	N/A	0x40000017	RW	N3 [15:8]							
M0_LSB	N/A	N/A	0x40000018	RW	M0 [7:0]							
M0_MSB	N/A	N/A	0x40000019	RW	M0 [15:8]							
M1_MSB	N/A	N/A	0x4000001A	RW	M1 [7:0]							
M1_LSB	N/A	N/A	0x4000001B	RW	M1 [15:8]							
M2_LSB	N/A	N/A	0x4000001C	RW	M2 [7:0]							
M2_MSB	N/A	N/A	0x4000001D	RW	M2 [15:8]							
M3_LSB	N/A	N/A	0x4000001E	RW	M3 [7:0]							



**Table 10. PGA302 Control and Status Registers (continued)**

Register Name	DI Page Address	DI Offset Address	EEPROM Address	R/W	D7	D6	D5	D4	D3	D2	D1	D0
M3_MSB	N/A	N/A	0x4000001F	RW	M3 [15:8]							
PADC_GAIN	N/A	N/A	0x40000020	RW	PADC_GAIN [7:0]							
TADC_GAIN	N/A	N/A	0x40000021	RW	TADC_GAIN [7:0]							
PADC_OFFSET_BYTE0	N/A	N/A	0x40000022	RW	PADC_OFFSET [7:0]							
PADC_OFFSET_BYTE1	N/A	N/A	0x40000023	RW	PADC_OFFSET [15:8]							
TADC_OFFSET_BYTE0	N/A	N/A	0x40000024	RW	TADC_OFFSET [7:0]							
TADC_OFFSET_BYTE1	N/A	N/A	0x40000025	RW	TADC_OFFSET [15:8]							
P_GAIN_SELECT	0x2	0x47	0x40000026	RW	P_INV		P_MUX_CTRL[1]	P_MUX_CTRL[0]	PSEM	P_GAIN[2]	P_GAIN[1]	P_GAIN[0]
T_GAIN_SELECT	0x2	0x48	0x40000027	RW	T_INV	Write 0	T_MUX_CTRL[1]	T_MUX_CTRL[0]	TSEM	T_GAIN[2]	T_GAIN[1]	T_GAIN[0]
TEMP_CTRL	0x2	0x4C	N/A	RW	Write 0	ITEMP_CTRL[2]	ITEMP_CTRL[1]	ITEMP_CTRL[0]				
TEMP_SW_CTRL	N/A	N/A	0x40000028	RW	Write 0	ITEMP_CTRL[2]	ITEMP_CTRL[1]	ITEMP_CTRL[0]	OFFSET_EN	DIAG_ENABLE	DACCAP_EN	EEPROM_LOCK
OFFSET_CANCEL	0x2	0x4E	0x40000029	RW			Write 0	OFFSET_CANCEL_V AL[4]	OFFSET_CANCEL_V AL[3]	OFFSET_CANCEL_V AL[2]	OFFSET_CANCEL_V AL[1]	OFFSET_CANCEL_V AL[0]
DAC_FAULT_MSB	N/A	N/A	0x4000002A	RW	DAC_FAULT[15:8]							
LPF_A0_MSB	N/A	N/A	0x4000002B	RW	A0 [15:8]							
LPF_A1_LSB	N/A	N/A	0x4000002C	RW	A1 [7:0]							
LPF_A1_MSB	N/A	N/A	0x4000002D	RW	A1 [15:8]							
LPF_A2_LSB	N/A	N/A	0x4000002E	RW	A2 [7:0]							
LPF_A2_MSB	N/A	N/A	0x4000002F	RW	A2 [15:8]							
LPF_B1_LSB	N/A	N/A	0x40000030	RW	B1 [7:0]							
LPF_B1_MSB	N/A	N/A	0x40000031	RW	B1 [15:8]							
PADC_DATA1	0x2	0x20	N/A	R	PADC_DATA [7:0]							
PADC_DATA2	0x2	0x21	N/A	R	PADC_DATA [15:8]							
TADC_DATA1	0x2	0x24	N/A	R	TADC_DATA [7:0]							
TADC_DATA2	0x2	0x25	N/A	R	TADC_DATA [15:8]							
DAC_REG0_1	0x2	0x30	N/A	RW	DAC_VALUE [7:0]							

**Table 10. PGA302 Control and Status Registers (continued)**

Register Name	DI Page Address	DI Offset Address	EEPROM Address	R/W	D7	D6	D5	D4	D3	D2	D1	D0	
DAC_REG0_2	0x2	0x31	N/A	RW					DAC_VALUE [11:8]				
OP_STAGE_CTRL	0x2	0x3B	N/A	RW				DACCAP_EN					
NORMAL_LOW_LSB	N/A	N/A	0x40000032	RW	NORMAL_DAC_LOW [7:0]								
NORMAL_LOW_MSB	N/A	N/A	0x40000033	RW					NORMAL_DAC_LOW [11:8]				
NORMAL_HIGH_LSB	N/A	N/A	0x40000034	RW	NORMAL_DAC_HIGH [7:0]								
NORMAL_HIGH_MSB	N/A	N/A	0x40000035	RW					NORMAL_DAC_HIGH [11:8]				
LOW_CLAMP_LSB	N/A	N/A	0x40000036	RW	CLAMP_DAC_LOW [7:0]								
LOW_CLAMP_MSB	N/A	N/A	0x40000037	RW					CLAMP_DAC_LOW [11:8]				
HIGH_CLAMP_LSB	N/A	N/A	0x40000038	RW	CLAMP_DAC_HIGH [7:0]								
HIGH_CLAMP_MSB	N/A	N/A	0x40000039	RW					CLAMP_DAC_HIGH [11:8]				
DIAG_BIT_EN	N/A	N/A	0x4000003A	RW	TGAIN_UV_EN	TGAIN_OV_EN	PGAIN_UV_EN	PGAIN_OV_EN		VINT_OV_EN	VINP_UV_EN	VINP_OV_EN	
PSMON1	0x2	0x58	N/A	RW				DVDD_OV	REF_UV	REF_OV	VBRG_UV	VBRG_OV	
AFEDIAG	0x2	0x5A	N/A	RW	TGAIN_UV	TGAIN_OV	PGAIN_UV	PGAIN_OV		VINT_OV	VINP_UV	VINP_OV	
SERIAL_NUMBER_BYTE0	N/A	N/A	0x4000003B	RW	SERIAL_NUMBER [7:0]								
SERIAL_NUMBER_BYTE1	N/A	N/A	0x4000003C	RW	SERIAL_NUMBER [15:8]								
SERIAL_NUMBER_BYTE2	N/A	N/A	0x4000003D	RW	SERIAL_NUMBER [23:16]								
SERIAL_NUMBER_BYTE3	N/A	N/A	0x4000003E	RW	SERIAL_NUMBER [31:24]								
USER_FREE_SPACE	N/A	N/A	0x4000003F-0x4000007E	RW									
EEPROM_CRC	N/A	N/A	0x4000007F	RW	EEPROM_CRC [7:0]								
MICRO_INTERFACE_CONTROL	0x0	0x0C	N/A	RW							MICRO_RESET	IF_SEL	
EEPROM_ARRAY	0x5	0x00-0x7F	N/A	R									

**Table 10. PGA302 Control and Status Registers (continued)**

Register Name	DI Page Address	DI Offset Address	EEPROM Address	R/W	D7	D6	D5	D4	D3	D2	D1	D0	
EEPROM_CACHE	0x5	0x80-0x81	N/A	RW									
EEPROM_PAGE_ADDRESS	0x5	0x82	N/A	RW			ADDR[5]	ADDR[4]	ADDR[3]	ADDR[2]	ADDR[1]	ADDR[0]	
EEPROM_CTRL	0x5	0x83	N/A	RW						Write 0	ERASE	PROGRAM	
EEPROM_CRC	0x5	0x84	N/A	RW								CALCULATE_CRC	
EEPROM_STATUS	0x5	0x85	N/A	R						PROGRAM_IN_PROGRESS	ERASE_IN_PROGRESS	READ_IN_PROGRESS	
EEPROM_CRC_STATUS	0x5	0x86	N/A	R							CRC_GOOD	CRC_CHECK_IN_PROG	
EEPROM_CRC_VALUE	0x5	0x87	N/A	R	EEPROM_CRC_VALUE [7:0]								

**8.5.1.2.1 MICRO\_INTERFACE\_CONTROL (DI Page Address = 0x0) (DI Page Offset = 0x0C)**
**Figure 36. MICRO\_INTERFACE\_CONTROL Register**

7	6	5	4	3	2	1	0
Reserved	Reserved	Reserved	Reserved	Reserved	Reserved	MICRO_RESE T	IF_SEL
N/A	N/A	N/A	N/A	N/A	N/A	R/W-0	R/W-0

**Table 11. MICRO\_INTERFACE\_CONTROL Register Field Descriptions**

Bit	Field	Type	Reset	Description
0	IF_SEL	R/W	0x00	1: Digital Interface accesses the memory 0: Ccontroller accesses the memory
1	MICRO_RESET	R/W	0x00	1: Controller Reset 0: Controller Running
2:7	Reserved	N/A	0x00	Reserved

**8.5.1.2.2 PSMON1 (M0 Address= 0x40000558) (DI Page Address = 0x2) (DI Page Offset = 0x58)**
**Figure 37. PSMON1 Register**

7	6	5	4	3	2	1	0
Reserved	Reserved	Reserved	DVDD_OV	REF_UV	REF_OV	VBRG_UV	VBRG_OV
N/A	R/W-0	N/A	R/W-0	R/W-0	R/W-0	R/W-0	R/W-0

**Table 12. PSMON1 Register Field Descriptions**

Bit	Field	Type	Reset	Description
0	VBRG_OV	R/W	0x00	<b>Read:</b> 1: VBRG is overvoltage 0: VBRG is not overvoltage <b>Write:</b> 1: Clears VBRG_OV bit 0: No Action
1	VBRG_UV	R/W	0x00	<b>Read:</b> 1: VBRG is undervoltage 0: VBRG is not undervoltage <b>Write:</b> 1: Clears VBRG_UV bit 0: No Action
2	REF_OV	R/W	0x00	<b>Read:</b> 1: Reference is overvoltage 0: Reference is not overvoltage <b>Write:</b> 1: Clears REF_OV bit 0: No Action
3	REF_UV	R/W	0x00	<b>Read:</b> 1: Reference is undervoltage 0: Reference is not undervoltage <b>Write:</b> 1: Clears REF_UV bit 0: No Action
4	DVDD_OV	R/W	0x00	<b>Read:</b> 1: DVDD is overvoltage 0: DVDD is not overvoltage <b>Write:</b> 1: Clears DVDD_OV bit 0: No Action
5	Reserved	N/A	0x00	Reserved
6	Reserved	N/A	0x00	Reserved
7	Reserved	N/A	0x00	Reserved

**8.5.1.2.3 AFEDIAG (M0 Address= 0x400055A) (DI Page Address = 0x2) (DI Page Offset = 0x5A)**
**Figure 38. AFEDIAG Register**

7	6	5	4	3	2	1	0
TGAIN_UV	TGAIN_OV	PGAIN_UV	PGAIN_OV	Reserved	VINT_OV	VINP_UV	VINP_OV
R/W-0	R/W-0	R/W-0	R/W-0	R/W-0	R/W-0	R/W-0	R/W-0

**Table 13. AFEDIAG Register Field Descriptions**

Bit	Field	Type	Reset	Description
0	VINP_OV	R/W	0x00	<b>Read:</b> 1: Indicates overvoltage at input pins of P Gain 0: Indicates no overvoltage at input pins of P Gain <b>Write:</b> 1: Clears VINP_OV bit 0: No Action
1	VINP_UV	R/W	0x00	<b>Read:</b> 1: Indicates undervoltage at input pins of P Gain 0: Indicates no undervoltage at input pins of P Gain <b>Write:</b> 1: Clears VINP_UV bit 0: No Action
2	VINT_OV	R/W	0x00	<b>Read:</b> 1: Indicates overvoltage at input pins of T Gain 0: Indicates no overvoltage at input pins of T Gain <b>Write:</b> 1: Clears VINT_OV bit 0: No Action
3	Reserved	R/W	0x00	
4	PGAIN_OV	R/W	0x00	<b>Read:</b> 1: Indicates overvoltage at output of P Gain 0: Indicates no overvoltage at output of P Gain <b>Write:</b> 1: Clears PGAIN_OV bit 0: No Action
5	PGAIN_UV	R/W	0x00	<b>Read:</b> 1: Indicates undervoltage at output of P Gain 0: Indicates no undervoltage at output of P Gain <b>Write:</b> 1: Clears PGAIN_UV bit 0: No Action
6	TGAIN_OV	R/W	0x00	<b>Read:</b> 1: Indicates overvoltage at output of T Gain 0: Indicates no overvoltage at output of T Gain <b>Write:</b> 1: Clears TGAIN_OV bit 0: No Action
7	TGAIN_UV	R/W	0x00	<b>Read:</b> 1: Indicates undervoltage at output of T Gain 0: Indicates no undervoltage at output of T Gain <b>Write:</b> 1: Clears TGAIN_UV bit 0: No Action

**8.5.1.2.4 P\_GAIN\_SELECT (DI Page Address = 0x2) (DI Page Offset = 0x47)**
**Figure 39. P\_GAIN\_SELECT Register**

7	6	5	4	3	2	1	0
P_INV	Reserved	P_MUX_CTRL[1]	P_MUX_CTRL[0]	PSEM	P_GAIN[2]	P_GAIN[1]	P_GAIN[0]
R/W-0	R/W-0	R/W-0	R/W-0	R/W-0	R/W-0	R/W-0	R/W-0

**Table 14. P\_GAIN\_SELECT Register Field Descriptions**

Bit	Field	Type	Reset	Description
0	P_GAIN[0]	R/W	0x00	See Electrical Parameters for Gain Selections
1	P_GAIN[1]	R/W	0x00	
2	P_GAIN[2]	R/W	0x00	
3	PSEM	R/W	0x00	1: Differential mode 0: Single-ended mode
4	P_MUX_CTRL[0]	R/W	0x00	P Channel Input MUX: 00: VINPP - VINPN 01: VINPP - 1.25V 10: 1.25V - VINPN When P_INV =1 the order is reversed
5	P_MUX_CTRL[1]	R/W	0x00	
6	Reserved	R/W	0x00	Reserved
7	P_INV	R/W	0x00	1: Inverts the output of the GAIN Output for pressure channel 0: No Inversion

**8.5.1.2.5 T\_GAIN\_SELECT (DI Page Address = 0x2) (DI Page Offset = 0x48)**
**Figure 40. T\_GAIN\_SELECT Register**

7	6	5	4	3	2	1	0
T_INV	T_MUX_CTRL[2]	T_MUX_CTRL[1]	T_MUX_CTRL[0]	TSEM	T_GAIN[2]	T_GAIN[1]	T_GAIN[0]
R/W-0	R/W-0	R/W-0	R/W-0	R/W-0	R/W-0	R/W-0	R/W-0

**Table 15. T\_GAIN\_SELECT Register Field Descriptions**

Bit	Field	Type	Reset	Description
0	T_GAIN[0]	R/W	0x00	See Electrical Parameters for Gain Selections
1	T_GAIN[1]	R/W	0x00	
2	T_GAIN[2]	R/W	0x00	
3	TSEM	R/W	0x00	1: Differential mode 0: Single-ended mode
4	T_MUX_CTRL[0]	R/W	0x00	0b000: External Temperature Sensor 0b001: TEST1 0b010: Internal Temperature Sensor 0b011: Bridge Current 0b100: ITEMP Pin Voltage
5	T_MUX_CTRL[1]	R/W	0x00	
6	T_MUX_CTRL[2]	R/W	0x00	
7	T_INV	R/W	0x00	1: Inverts the output of the GAIN Output for pressure channel 0: No Inversion

8.5.1.2.6 TEMP\_CTRL (DI Page Address = 0x2) (DI Page Offset = 0x4C)

Figure 41. TEMP\_CTRL Register

7	6	5	4	3	2	1	0
ITEMP_DST_SEL	ITEMP_CTRL[2]	ITEMP_CTRL[1]	ITEMP_CTRL[0]	Reserved	Reserved	Reserved	Reserved
R/W-0	R/W-1	R/W-0	R/W-0	N/A	N/A	N/A	N/A

Table 16. TEMP\_CTRL Register Field Descriptions

Bit	Field	Type	Reset	Description
0:3	Reserved	N/A	0x00	Reserved
4:6	ITEMP_CTRL[3:0]	R/W	0x00	0x00: 50 $\mu$ A 0x01: 100 $\mu$ A 0x02: 200 $\mu$ A 0x03: 1000 $\mu$ A 0x04 - 0x07: OFF
7	ITEMP_DST_SEL	R/W	0x00	0: ITEMP is driven to VINTP pin 1: ITEMP is driven to ITEMP pin

8.5.1.2.7 OFFSET\_CANCEL (DI Page Address = 0x2) (DI Page Offset = 0x4E)

Figure 42. OFFSET\_CANCEL Register

7	6	5	4	3	2	1	0
Reserved	Reserved	Reserved	OFFSET_CANCEL_SEL	OFFSET_CANCEL_VAL[3]	OFFSET_CANCEL_VAL[2]	OFFSET_CANCEL_VAL[1]	OFFSET_CANCEL_VAL[0]
N/A	N/A	N/A	R/W-0	R/W-0	R/W-0	R/W-0	R/W-0

Table 17. OFFSET\_CANCEL Register Field Descriptions

Bit	Field	Type	Reset	Description
0	OFFSET_CANCEL_VAL[0]	R/W	0x00	0x00: 0 mV
1	OFFSET_CANCEL_VAL[1]	R/W	0x00	0x01: 3.65 mV
2	OFFSET_CANCEL_VAL[2]	R/W	0x00	0x02: 7.3 mV
3	OFFSET_CANCEL_VAL[3]	R/W	0x00	0x03: 10.95 mV 0x04: 14.6 mV 0x05: 18.28 mV 0x06: 21.9 mV 0x07: 25.55 mV 0x08: 29.2mV 0x09: 32.85 mV 0x0A: 36.5 mV 0x0B: 40.15mV 0x0C: 43.8 mV 0x0D: 47.45mV 0x0E: 51.1 mV 0x0F: 54.75 mV
4	OFFSET_CANCEL_SEL	R/W	0x00	1: Offset current is connected to VINPP pin (Positive Offset) 0: Offset current is connected to VINPN pin (Negative Offset)
5:7	Reserved	N/A	0x00	Reserved



**8.5.1.2.8 PADC\_DATA1 (DI Page Address = 0x0) (DI Page Offset = 0x10)**

- To read PADC\_DATA from Digital Interface, the least significant byte/word should be read first. This returns the least significant byte/word. The most significant bytes are latched into a shadow register. Reads to the Digital Interface addresses 0x11 return data from this shadow register.
- In 16-bit mode, PADC\_DATA1 will be the least significant byte and PADC\_DATA2 is the most significant byte.

**Figure 43. PADC\_DATA1 Register**

7	6	5	4	3	2	1	0
PADC_DATA [7:0]							
R-0	R-0	R-0	R-0	R-0	R-0	R-0	R-0

**Table 18. PADC\_DATA1 Register Field Descriptions**

Bit	Field	Type	Reset	Description
0:7	PADC_DATA [7:0]	R	0x00	Pressure ADC Output LS Byte

**8.5.1.2.9 PADC\_DATA2 (DI Page Address = 0x0) (DI Page Offset = 0x11)**

- To read PADC\_DATA from Digital Interface, the least significant byte/word should be read first. This returns the least significant byte/word. The most significant bytes are latched into a shadow register. Reads to the Digital Interface addresses 0x11 return data from this shadow register.
- In 16-bit mode, PADC\_DATA1 will be the least significant byte and PADC\_DATA2 is the most significant byte.

**Figure 44. PADC\_DATA2 Register**

7	6	5	4	3	2	1	0
PADC_DATA [15:8]							
R-0	R-0	R-0	R-0	R-0	R-0	R-0	R-0

**Table 19. PADC\_DATA2 Register Field Descriptions**

Bit	Field	Type	Reset	Description
0:7	PADC_DATA	R	0x00	Pressure ADC Output MS Byte

**8.5.1.2.10 TADC\_DATA1 (DI Page Address = 0x0) (DI Page Offset = 0x14)**

- To read TADC\_DATA from Digital Interface, the least significant byte/word should be read first. This returns the least significant byte/word. The most significant bytes are latched into a shadow register. Reads to the Digital Interface addresses 0x15 return data from this shadow register.
- In 16-bit mode, TADC\_DATA1 will be the least significant byte and TADC\_DATA2 is the most significant byte.

**Figure 45. TADC\_DATA1 Register**

7	6	5	4	3	2	1	0
TADC_DATA [7:0]							
R-0	R-0	R-0	R-0	R-0	R-0	R-0	R-0

**Table 20. TADC\_DATA1 Register Field Descriptions**

Bit	Field	Type	Reset	Description
0:7	TADC_DATA	R	0x00	Temperature ADC Output LS Byte

**8.5.1.2.11 TADC\_DATA2 (DI Page Address = 0x0) (DI Page Offset = 0x15)**

- To read TADC\_DATA from Digital Interface, the least significant byte/word should be read first. This returns the least significant byte/word. The most significant bytes are latched into a shadow register. Reads to the Digital Interface addresses 0x15 return data from this shadow register.
- In 16-bit mode, TADC\_DATA1 will be the least significant byte and TADC\_DATA2 is the most significant byte.

**Figure 46. TADC\_DATA2 Register**

7	6	5	4	3	2	1	0
TADC_DATA [15:8]							
R-0	R-0	R-0	R-0	R-0	R-0	R-0	R-0

**Table 21. TADC\_DATA2 Register Field Descriptions**

Bit	Field	Type	Reset	Description
0:7	TADC_DATA	R	0x00	Temperature ADC Output MS Byte

**8.5.1.2.12 DAC\_REG0\_1 (DI Page Address = 0x2) (DI Page Offset = 0x30)**

DAC Register Usage:

**Figure 47. DAC\_REG0\_1 Register**

7	6	5	4	3	2	1	0
DAC_VAL [7:0]							
R/W-0	R/W-0	R/W-0	R/W-0	R/W-0	R/W-0	R/W-0	R/W-0

**Table 22. DAC\_REG0\_1 Register Field Descriptions**

Bit	Field	Type	Reset	Description
0:7	DAC_VAL	R/W	0x00	DAC Output value LS Byte

**8.5.1.2.13 DAC\_REG0\_2 (DI Page Address = 0x2) (DI Page Offset = 0x31)**

DAC Register Usage:

**Figure 48. DAC\_REG0\_2 Register**

7	6	5	4	3	2	1	0
Reserved	Reserved	Reserved	Reserved	DAC_VAL [11:8]			
R/W-0	R/W-0	R/W-0	R/W-0	R/W-0	R/W-0	R/W-0	R/W-0

**Table 23. DAC\_REG0\_2 Register Field Descriptions**

Bit	Field	Type	Reset	Description
0:3	DAC_VAL	R/W	0x00	DAC Output value MS Nibble
4:7	Reserved	N/A	0x00	Reserved

**8.5.1.2.14 OP\_STAGE\_CTRL (DI Page Address = 0x2) (DI Page Offset = 0x3B)**
**Figure 49. OP\_STAGE\_CTRL Register**

7	6	5	4	3	2	1	0
Reserved	Reserved	Reserved	DACCAP_EN	Reserved	Reserved	Reserved	Reserved
N/A	N/A	N/A	R/W-0	N/A	N/A	N/A	N/A

**Table 24. OP\_STAGE\_CTRL Register Field Descriptions**

Bit	Field	Type	Reset	Description
0:3	Reserved	N/A	0x00	Reserved
4	DACCAP_EN	R/W	0x00	1: Enable DACCAP capacitor (Close switch S4 in DAC Gain) 0: Disable DACCAP capacitor (Open switch S4 in DAC Gain)
5:7	Reserved	N/A	0x00	Reserved

**8.5.1.2.15 EEPROM\_ARRAY (DI Page Address = 0x5) (DI Page Offset = 0x00 - 0x7F)**
**Figure 50. EEPROM\_ARRAY Register Range**

7	6	5	4	3	2	1	0
DATA[7]	DATA[6]	DATA[5]	DATA[4]	DATA[3]	DATA[2]	DATA[1]	DATA[0]
RW-0	RW-0	RW-0	RW-0	RW-0	RW-0	RW-0	RW-0

**Table 25. EEPROM\_ARRAY Register Range Descriptions**

Bit	Field	Type	Reset	Description
0:7	DATA[0] : DATA[7]	R/W	0x00	EEPROM Read Memory. The EEPROM data can be directly read from these register locations. For EEPROM programming use EEPROM_CACHE_BYTE0, EEPROM_CACHE_BYTE1, EEPROM_PAGE_ADDRESS and EEPROM_CTRL Registers.

**8.5.1.2.16 EEPROM\_CACHE\_BYTE0 (DI Page Address = 0x5) (DI Page Offset = 0x80)**
**Figure 51. EEPROM\_CACHE\_BYTE0 Register**

7	6	5	4	3	2	1	0
DATA[7]	DATA[6]	DATA[5]	DATA[4]	DATA[3]	DATA[2]	DATA[1]	DATA[0]
RW-0	RW-0	RW-0	RW-0	RW-0	RW-0	RW-0	RW-0

**Table 26. EEPROM\_CACHE\_BYTE0 Register Field Descriptions**

Bit	Field	Type	Reset	Description
0:7	DATA[0] : DATA[7]	R/W	0x00	EEPROM Programming Cache Byte0

**8.5.1.2.17 EEPROM\_CACHE\_BYTE1 (DI Page Address = 0x5) (DI Page Offset = 0x81)**
**Figure 52. EEPROM\_CACHE\_BYTE1 Register**

7	6	5	4	3	2	1	0
DATA[7]	DATA[6]	DATA[5]	DATA[4]	DATA[3]	DATA[2]	DATA[1]	DATA[0]
RW-0	RW-0	RW-0	RW-0	RW-0	RW-0	RW-0	RW-0

**Table 27. EEPROM\_CACHE\_BYTE1 Register Field Descriptions**

Bit	Field	Type	Reset	Description
0:7	DATA[0] : DATA[7]	R/W	0x00	EEPROM Programming Cache Byte1

**8.5.1.2.18 EEPROM\_PAGE\_ADDRESS (DI Page Address = 0x5) (DI Page Offset = 0x82)**
**Figure 53. EEPROM\_PAGE\_ADDRESS Register**

7	6	5	4	3	2	1	0
Reserved	Reserved	ADDR[5]	ADDR[4]	ADDR[3]	ADDR[2]	ADDR[1]	ADDR[0]
N/A	N/A	RW-0	RW-0	RW-0	RW-0	RW-0	RW-0

**Table 28. EEPROM\_PAGE\_ADDRESS Register Field Descriptions**

Bit	Field	Type	Reset	Description
0	ADDR[0]	R/W	0x00	
1	ADDR[1]	R/W	0x00	
2	ADDR[2]	R/W	0x00	
3	ADDR[3]	R/W	0x00	
4	ADDR[4]	R/W	0x00	
5	ADDR[5]	R/W	0x00	
6:7	Reserved	N/A	0x00	Reserved

**8.5.1.2.19 EEPROM\_CTRL (DI Page Address = 0x5) (DI Page Offset = 0x83)**
**Figure 54. EEPROM\_CTRL Register**

7	6	5	4	3	2	1	0
Reserved	Reserved	Reserved	Reserved	Reserved	Write 0	ERASE	PROGRAM
N/A	N/A	N/A	N/A	N/A	RW-0	RW-0	RW-0

**Table 29. EEPROM\_CTRL Register Field Descriptions**

Bit	Field	Type	Reset	Description
0	PROGRAM	R/W	0x00	1: Program contents of EEPROM cache into EEPROM memory pointed to by EEPROM_PAGE_ADDRESS 0: No action
1	ERASE	R/W	0x00	1: Erase contents of EEPROM memory pointed to by EEPROM_PAGE_ADDRESS 0: No action
2	Reserved	R/W	0x00	Reserved
3:7	Reserved	N/A	0x00	Reserved

**8.5.1.2.20 EEPROM\_CRC (DI Page Address = 0x5) (DI Page Offset = 0x84)**
**Figure 55. EEPROM\_CRC Register**

7	6	5	4	3	2	1	0
Reserved	Reserved	Reserved	Reserved	Reserved	Reserved	Reserved	CALCULATE_CRC
N/A	N/A	N/A	N/A	N/A	N/A	N/A	RW-0

**Table 30. EEPROM\_CRC Register Field Descriptions**

Bit	Field	Type	Reset	Description
0	CALCULATE_CRC	R/W	0x00	1: Calculate EEPROM CRC 0: No action
1:7	Reserved	N/A	0x00	Reserved

**8.5.1.2.21 EEPROM\_STATUS (DI Page Address = 0x5) (DI Page Offset = 0x85)**

**Figure 56. EEPROM\_STATUS Register**

7	6	5	4	3	2	1	0
Reserved	Reserved	Reserved	Reserved	Reserved	PROGRAM_IN_PROGRESS	ERASE_IN_PROGRESS	READ_IN_PROGRESS
N/A	N/A	N/A	N/A	N/A	R-0	R-0	R-0

**Table 31. EEPROM\_STATUS Register Field Descriptions**

Bit	Field	Type	Reset	Description
0	READ_IN_PROGRESS	R	0x00	1: EEPROM Read in progress 0: EEPROM Read not in progress
1	ERASE_IN_PROGRESS	R	0x00	1: EEPROM Erase in progress 0: EEPROM Erase not in progress
2	PROGRAM_IN_PROGRESS	R	0x00	1: EEPROM Program in progress 0: EEPROM Program not in progress
3:7	Reserved	N/A	0x00	Reserved

**8.5.1.2.22 EEPROM\_CRC\_STATUS (DI Page Address = 0x5) (DI Page Offset = 0x86)**

**Figure 57. EEPROM\_CRC\_STATUS Register**

7	6	5	4	3	2	1	0
Reserved	Reserved	Reserved	Reserved	Reserved	Reserved	CRC_GOOD	CRC_CHECK_IN_PROG
N/A	N/A	N/A	N/A	N/A	N/A	R-0	R-0

**Table 32. EEPROM\_CRC\_STATUS Register Field Descriptions**

Bit	Field	Type	Reset	Description
0	CRC_CHECK_IN_PROGRESS	R	0x00	1: EEPROM CRC check in progress 0: EEPROM CRC check not in progress
1	CRC_GOOD	R	0x00	1: EEPROM Programmed CRC matches calculated CRC 0: EEPROM Programmed CRC does not match calculated CRC
2:7				

**8.5.1.2.23 EEPROM\_CRC\_VALUE (DI Page Address = 0x5) (DI Page Offset = 0x87)**

EEPROM CRC value should be located in the last byte of the EEPROM.

**Figure 58. EEPROM\_CRC\_VALUE Register**

7	6	5	4	3	2	1	0
EEPROM_CRC_VALUE [7:0]							
R-1	R-1	R-1	R-1	R-1	R-1	R-1	R-1

**Table 33. EEPROM\_CRC\_VALUE Register Field Descriptions**

Bit	Field	Type	Reset	Description
0:7	EEPROM_CRC_VALUE	R	0x01	Device Calculated EEPROM CRC value

**8.5.1.2.24 H0 (EEPROM Address= 0x40000000)**
**Figure 59. H0\_LSB Register**

7	6	5	4	3	2	1	0
H0 [7:0]							
RW-0	RW-0	RW-0	RW-0	RW-0	RW-0	RW-0	RW-0

**Figure 60. H0\_MSB Register**

7	6	5	4	3	2	1	0
H0 [15:8]							
RW-0	RW-0	RW-0	RW-0	RW-0	RW-0	RW-0	RW-0

**Table 34. H0 Register Field Descriptions**

Bit	Field	Type	Reset	Description
0:15	H0	R/W	0x00	H0 Linearization Coefficient (2's complement value)

**8.5.1.2.25 H1 (EEPROM Address= 0x40000002)**
**Figure 61. H1\_LSB Register**

7	6	5	4	3	2	1	0
H1 [7:0]							
RW-0	RW-0	RW-0	RW-0	RW-0	RW-0	RW-0	RW-0

**Figure 62. H1\_MSB Register**

7	6	5	4	3	2	1	0
H1 [15:8]							
RW-0	RW-0	RW-0	RW-0	RW-0	RW-0	RW-0	RW-0

**Table 35. H1 Register Field Descriptions**

Bit	Field	Type	Reset	Description
0:15	H1	R/W	0x00	H1 Linearization Coefficient (2's complement value)

**8.5.1.2.26 H2 (EEPROM Address= 0x40000004)**
**Figure 63. H2\_LSB Register**

7	6	5	4	3	2	1	0
H2 [7:0]							
RW-0	RW-0	RW-0	RW-0	RW-0	RW-0	RW-0	RW-0

**Figure 64. H2\_MSB Register**

7	6	5	4	3	2	1	0
H2 [15:8]							
RW-0	RW-0	RW-0	RW-0	RW-0	RW-0	RW-0	RW-0

**Table 36. H2 Register Field Descriptions**

Bit	Field	Type	Reset	Description
0:15	H2	R/W	0x00	H2 Linearization Coefficient (2's complement value)

**8.5.1.2.27 H3 (EEPROM Address= 0x40000006)**
**Figure 65. H3\_LSB Register**

7	6	5	4	3	2	1	0
H3 [7:0]							
RW-0	RW-0	RW-0	RW-0	RW-0	RW-0	RW-0	RW-0

**Figure 66. H3\_MSB Register**

7	6	5	4	3	2	1	0
H3 [15:8]							
RW-0	RW-0	RW-0	RW-0	RW-0	RW-0	RW-0	RW-0

**Table 37. H3 Register Field Descriptions**

Bit	Field	Type	Reset	Description
0:15	H3	R/W	0x00	H3 Linearization Coefficient (2's complement value)

**8.5.1.2.28 G0 (EEPROM Address= 0x40000008)**
**Figure 67. G0\_LSB Register**

7	6	5	4	3	2	1	0
G0 [7:0]							
RW-0	RW-0	RW-0	RW-0	RW-0	RW-0	RW-0	RW-0

**Figure 68. G0\_MSB Register**

7	6	5	4	3	2	1	0
G0 [15:8]							
RW-0	RW-0	RW-0	RW-0	RW-0	RW-0	RW-0	RW-0

**Table 38. G0 Register Field Descriptions**

Bit	Field	Type	Reset	Description
0:15	G0	R/W	0x00	G0 Linearization Coefficient (2's complement value)

**8.5.1.2.29 G1 (EEPROM Address= 0x4000000A)**
**Figure 69. G1\_LSB Register**

7	6	5	4	3	2	1	0
G1 [7:0]							
RW-0	RW-0	RW-0	RW-0	RW-0	RW-0	RW-0	RW-0

**Figure 70. G1\_MSB Register**

7	6	5	4	3	2	1	0
G1 [15:8]							
RW-0	RW-0	RW-0	RW-0	RW-0	RW-0	RW-0	RW-0

**Table 39. G1 Register Field Descriptions**

Bit	Field	Type	Reset	Description
0:15	G1	R/W	0x00	G1 Linearization Coefficient (2's complement value)



**8.5.1.2.30 G2 (EEPROM Address= 0x4000000C)**
**Figure 71. G2\_LSB Register**

7	6	5	4	3	2	1	0
G2 [7:0]							
RW-0	RW-0	RW-0	RW-0	RW-0	RW-0	RW-0	RW-0

**Figure 72. G2\_MSB Register**

7	6	5	4	3	2	1	0
G2 [15:8]							
RW-0	RW-0	RW-0	RW-0	RW-0	RW-0	RW-0	RW-0

**Table 40. G2 Register Field Descriptions**

Bit	Field	Type	Reset	Description
0:15	G2	R/W	0x00	G2 Linearization Coefficient (2's complement value)

**8.5.1.2.31 G3 (EEPROM Address= 0x4000000E)**
**Figure 73. G3\_LSB Register**

7	6	5	4	3	2	1	0
G3 [7:0]							
RW-0	RW-0	RW-0	RW-0	RW-0	RW-0	RW-0	RW-0

**Figure 74. G3\_MSB Register**

7	6	5	4	3	2	1	0
G3 [15:8]							
RW-0	RW-0	RW-0	RW-0	RW-0	RW-0	RW-0	RW-0

**Table 41. G3 Register Field Descriptions**

Bit	Field	Type	Reset	Description
0:15	G3	R/W	0x00	G3 Linearization Coefficient (2's complement value)

**8.5.1.2.32 N0 (EEPROM Address= 0x40000010)**
**Figure 75. N0\_LSB Register**

7	6	5	4	3	2	1	0
N0 [7:0]							
RW-0	RW-0	RW-0	RW-0	RW-0	RW-0	RW-0	RW-0

**Figure 76. N0\_MSB Register**

7	6	5	4	3	2	1	0
N0 [15:8]							
RW-0	RW-0	RW-0	RW-0	RW-0	RW-0	RW-0	RW-0

**Table 42. N0 Register Field Descriptions**

Bit	Field	Type	Reset	Description
0:15	N0	R/W	0x00	N0 Linearization Coefficient (2's complement value)

**8.5.1.2.33 N1 (EEPROM Address= 0x40000012)**
**Figure 77. N1\_LSB Register**

7	6	5	4	3	2	1	0
N1 [7:0]							
RW-0	RW-0	RW-0	RW-0	RW-0	RW-0	RW-0	RW-0

**Figure 78. N1\_MSB Register**

7	6	5	4	3	2	1	0
N1 [15:8]							
RW-0	RW-0	RW-0	RW-0	RW-0	RW-0	RW-0	RW-0

**Table 43. N1 Register Field Descriptions**

Bit	Field	Type	Reset	Description
0:15	N1	R/W	0x00	N1 Linearization Coefficient (2's complement value)

**8.5.1.2.34 N2 (EEPROM Address= 0x40000014)**
**Figure 79. N2\_LSB Register**

7	6	5	4	3	2	1	0
N2 [7:0]							
RW-0	RW-0	RW-0	RW-0	RW-0	RW-0	RW-0	RW-0

**Figure 80. N2\_MSB Register**

7	6	5	4	3	2	1	0
N2 [15:8]							
RW-0	RW-0	RW-0	RW-0	RW-0	RW-0	RW-0	RW-0

**Table 44. N2 Register Field Descriptions**

Bit	Field	Type	Reset	Description
0:15	N2	R/W	0x00	N2 Linearization Coefficient (2's complement value)

**8.5.1.2.35 N3 (EEPROM Address= 0x40000016)**
**Figure 81. N3\_LSB Register**

7	6	5	4	3	2	1	0
N3 [7:0]							
RW-0	RW-0	RW-0	RW-0	RW-0	RW-0	RW-0	RW-0

**Figure 82. N3\_MSB Register**

7	6	5	4	3	2	1	0
N3 [15:8]							
RW-0	RW-0	RW-0	RW-0	RW-0	RW-0	RW-0	RW-0

**Table 45. N3 Register Field Descriptions**

Bit	Field	Type	Reset	Description
0:15	N3	R/W	0x00	N3 Linearization Coefficient (2's complement value)

**8.5.1.2.36 M0 (EEPROM Address= 0x40000018)**
**Figure 83. M0\_LSB Register**

7	6	5	4	3	2	1	0
M0 [7:0]							
RW-0	RW-0	RW-0	RW-0	RW-0	RW-0	RW-0	RW-0

**Figure 84. M0\_MSB Register**

7	6	5	4	3	2	1	0
M0 [15:8]							
RW-0	RW-0	RW-0	RW-0	RW-0	RW-0	RW-0	RW-0

**Table 46. M0 Register Field Descriptions**

Bit	Field	Type	Reset	Description
0:15	M0	R/W	0x00	M0 Linearization Coefficient (2's complement value)

**8.5.1.2.37 M1 (EEPROM Address= 0x4000001A)**
**Figure 85. M1\_LSB Register**

7	6	5	4	3	2	1	0
M1 [7:0]							
RW-0	RW-0	RW-0	RW-0	RW-0	RW-0	RW-0	RW-0

**Figure 86. M1\_MSB Register**

7	6	5	4	3	2	1	0
M1 [15:8]							
RW-0	RW-0	RW-0	RW-0	RW-0	RW-0	RW-0	RW-0

**Table 47. M1 Register Field Descriptions**

Bit	Field	Type	Reset	Description
0:15	M1	R/W	0x00	M1 Linearization Coefficient (2's complement value)

**8.5.1.2.38 M2 (EEPROM Address= 0x4000001C)**
**Figure 87. M2\_LSB Register**

7	6	5	4	3	2	1	0
M2 [7:0]							
RW-0	RW-0	RW-0	RW-0	RW-0	RW-0	RW-0	RW-0

**Figure 88. M2\_MSB Register**

7	6	5	4	3	2	1	0
M2 [15:8]							
RW-0	RW-0	RW-0	RW-0	RW-0	RW-0	RW-0	RW-0

**Table 48. M2 Register Field Descriptions**

Bit	Field	Type	Reset	Description
0:15	M2	R/W	0x00	M2 Linearization Coefficient (2's complement value)

**8.5.1.2.39 M3 (EEPROM Address= 0x4000001E)**
**Figure 89. M3\_LSB Register**

7	6	5	4	3	2	1	0
M3 [7:0]							
RW-0	RW-0	RW-0	RW-0	RW-0	RW-0	RW-0	RW-0

**Figure 90. M3\_MSB Register**

7	6	5	4	3	2	1	0
M3 [15:8]							
RW-0	RW-0	RW-0	RW-0	RW-0	RW-0	RW-0	RW-0

**Table 49. M3 Register Field Descriptions**

Bit	Field	Type	Reset	Description
0:15	M3	R/W	0x00	M3 Linearization Coefficient (2's complement value)

**8.5.1.2.40 PADC\_GAIN (EEPROM Address= 0x40000020)**
**Figure 91. PADC\_GAIN Register**

7	6	5	4	3	2	1	0
PADC_GAIN [7:0]							
RW-0	RW-0	RW-0	RW-0	RW-0	RW-0	RW-0	RW-0

**Table 50. PADC\_GAIN Register Field Descriptions**

Bit	Field	Type	Reset	Description
0:7	PADC_GAIN	R/W	0x00	PADC digital Gain (Positive Value only)

**8.5.1.2.41 TADC\_GAIN (EEPROM Address= 0x40000021)**
**Figure 92. TADC\_GAIN Register**

7	6	5	4	3	2	1	0
TADC_GAIN [7:0]							
RW-0	RW-0	RW-0	RW-0	RW-0	RW-0	RW-0	RW-0

**Table 51. TADC\_GAIN Register Field Descriptions**

Bit	Field	Type	Reset	Description
0:7	TADC_GAIN	R/W	0x00	TADC digital Gain (Positive Value only)

**8.5.1.2.42 PADC\_OFFSET (EEPROM Address= 0x40000022)**
**Figure 93. PADC\_OFFSET\_BYTE0 Register**

7	6	5	4	3	2	1	0
PADC_OFFSET [7:0]							
RW-0	RW-0	RW-0	RW-0	RW-0	RW-0	RW-0	RW-0

**Figure 94. PADC\_OFFSET\_BYTE1 Register**

7	6	5	4	3	2	1	0
PADC_OFFSET [15:8]							
RW-0	RW-0	RW-0	RW-0	RW-0	RW-0	RW-0	RW-0

**Table 52. PADC\_OFFSET Register Field Descriptions**

Bit	Field	Type	Reset	Description
0:15	PADC_OFFSET	R/W	0x00	PADC digital offset (2's complement value)

**8.5.1.2.43 TADC\_OFFSET (EEPROM Address= 0x40000024)**
**Figure 95. TADC\_OFFSET\_BYTE0 Register**

7	6	5	4	3	2	1	0
TADC_OFFSET [7:0]							
RW-0	RW-0	RW-0	RW-0	RW-0	RW-0	RW-0	RW-0

**Figure 96. TADC\_OFFSET\_BYTE1 Register**

7	6	5	4	3	2	1	0
TADC_OFFSET [15:8]							
RW-0	RW-0	RW-0	RW-0	RW-0	RW-0	RW-0	RW-0

**Table 53. TADC\_OFFSET Register Field Descriptions**

Bit	Field	Type	Reset	Description
0:15	TADC_OFFSET	R/W	0x00	TADC digital offset (2's complement value)

**8.5.1.2.44 TEMP\_SW\_CTRL (EEPROM Address= 0x40000028)**
**Figure 97. TEMP\_SW\_CTRL Register**

7	6	5	4	3	2	1	0
Reserved	ITEMP_CTRL [2:0]			OFFSET_EN	DIAG_ENABLE	DACCAP_EN	EEPROM_LOCK
RW-0	RW-0	RW-0	RW-0	RW-0	RW-0	RW-0	RW-0

**Table 54. TEMP\_SW\_CTRL Register Field Descriptions**

Bit	Field	Type	Reset	Description
0	EEPROM_LOCK	R/W	0x00	0: Writing to EEPROM memory is enabled. 1: Writing to EEPROM memory is disabled.
1	DACCAP_EN	R/W	0x00	0: DACCAP pin is disconnected. 1: DACCAP pin is connected.
2	DIAG_ENABLE	R/W	0x00	AFE Global Diagnostics Enable. 0: Analog Diagnostics Disabled 1: Analog Diagnostics Enabled
3	OFFSET_EN	R/W	0x00	0: Normal mode Linearization algorithm is used. 1: High Sensor Offset Linearization Algorithm is used.
4:6	ITEMP_CTRL	R/W	0x00	See ITEMP_CTRL Register Description
7	Reserved	N/A		Reserved

**8.5.1.2.45 DAC\_FAULT\_MSB (EEPROM Address= 0x4000002A)**
**Figure 98. DAC\_FAULT\_MSB Register**

7	6	5	4	3	2	1	0
DAC_FAULT [15:8]							
RW-0	RW-0	RW-0	RW-0	RW-0	RW-0	RW-0	RW-0

**Table 55. DAC\_FAULT\_MSB Register Field Descriptions**

Bit	Field	Type	Reset	Description
8:15	DAC_FAULT	R/W	0x00	DAC Fault Value. When a fault is detected while diagnostics are enabled, the DAC will output the DAC_FAULT programmed value. DAC_FAULT [7:0] bits are fixed to 0x00 value.

**8.5.1.2.46 LPF\_A0\_MSB (EEPROM Address= 0x4000002B)**

**Figure 99. LPF\_A0\_MSB Register**

7	6	5	4	3	2	1	0
A0 [15:8]							
RW-0	RW-0	RW-0	RW-0	RW-0	RW-0	RW-0	RW-0

**Table 56. LPF\_A0\_MSB Register Field Descriptions**

Bit	Field	Type	Reset	Description
8:15	A0	R/W	0x00	Low Pass filter A0 coefficient. A0 [7:0] bits are fixed to 0x00 value.

**8.5.1.2.47 LPF\_A1 (EEPROM Address= 0x4000002C)**

**Figure 100. LPF\_A1\_LSB Register**

7	6	5	4	3	2	1	0
A1 [7:0]							
RW-0	RW-0	RW-0	RW-0	RW-0	RW-0	RW-0	RW-0

**Figure 101. LPF\_A1\_MSB Register**

7	6	5	4	3	2	1	0
A1 [15:8]							
RW-0	RW-0	RW-0	RW-0	RW-0	RW-0	RW-0	RW-0

**Table 57. A1 Register Field Descriptions**

Bit	Field	Type	Reset	Description
0:15	A1	R/W	0x00	Low Pass filter A1 coefficient.

**8.5.1.2.48 LPF\_A2 (EEPROM Address= 0x4000002E)**

**Figure 102. LPF\_A2\_LSB Register**

7	6	5	4	3	2	1	0
A2 [7:0]							
RW-0	RW-0	RW-0	RW-0	RW-0	RW-0	RW-0	RW-0

**Figure 103. LPF\_A2\_MSB Register**

7	6	5	4	3	2	1	0
A2 [15:8]							
RW-0	RW-0	RW-0	RW-0	RW-0	RW-0	RW-0	RW-0

**Table 58. A2 Register Field Descriptions**

Bit	Field	Type	Reset	Description
0:15	A2	R/W	0x00	Low Pass filter A2 coefficient.

**8.5.1.2.49 .LPF\_B1 (EEPROM Address= 0x40000030)**
**Figure 104. LPF\_B1\_LSB Register**

7	6	5	4	3	2	1	0
B1 [7:0]							
RW-0	RW-0	RW-0	RW-0	RW-0	RW-0	RW-0	RW-0

**Figure 105. LPF\_B1\_MSB Register**

7	6	5	4	3	2	1	0
B1 [15:8]							
RW-0	RW-0	RW-0	RW-0	RW-0	RW-0	RW-0	RW-0

**Table 59. B1 Register Field Descriptions**

Bit	Field	Type	Reset	Description
0:15	B1	R/W	0x00	Low Pass filter B1 coefficient.

**8.5.1.2.50 NORMAL\_LOW (EEPROM Address= 0x40000032)**
**Figure 106. NORMAL\_LOW\_LSB Register**

7	6	5	4	3	2	1	0
NORMAL_DAC_LOW [7:0]							
RW-0	RW-0	RW-0	RW-0	RW-0	RW-0	RW-0	RW-0

**Figure 107. NORMAL\_LOW\_MSB Register**

7	6	5	4	3	2	1	0
NORMAL_DAC_LOW [11:8]							
RW-0	RW-0	RW-0	RW-0	RW-0	RW-0	RW-0	RW-0

**Table 60. NORMAL\_LOW Register Field Descriptions**

Bit	Field	Type	Reset	Description
0:11	NORMAL_DAC_LOW	R/W	0x00	Normal DAC Output Low Threshold Range. If the DAC value goes below NORMAL_DAC_LOW value, then the DAC value will be clamped to CLAMP_DAC_LOW

**8.5.1.2.51 NORMAL\_HIGH (EEPROM Address= 0x40000034)**
**Figure 108. NORMAL\_HIGH\_LSB Register**

7	6	5	4	3	2	1	0
NORMAL_DAC_HIGH [7:0]							
RW-0	RW-0	RW-0	RW-0	RW-0	RW-0	RW-0	RW-0

**Figure 109. NORMAL\_HIGH\_MSB Register**

7	6	5	4	3	2	1	0
NORMAL_DAC_HIGH [11:8]							
RW-0	RW-0	RW-0	RW-0	RW-0	RW-0	RW-0	RW-0

**Table 61. NORMAL\_HIGH Register Field Descriptions**

Bit	Field	Type	Reset	Description
0:11	NORMAL_DAC_HIGH	R/W	0x00	Normal DAC Output High Threshold Range. If the DAC value goes above NORMAL_DAC_HIGH value, then the DAC value will be clamped to CLAMP_DAC_HIGH

**8.5.1.2.52 LOW\_CLAMP (EEPROM Address= 0x40000036)**
**Figure 110. LOW\_CLAMP\_LSB Register**

7	6	5	4	3	2	1	0
CLAMP_DAC_LOW [7:0]							
RW-0	RW-0	RW-0	RW-0	RW-0	RW-0	RW-0	RW-0

**Figure 111. LOW\_CLAMP\_MSB Register**

7	6	5	4	3	2	1	0
CLAMP_DAC_LOW [11:8]							
RW-0	RW-0	RW-0	RW-0	RW-0	RW-0	RW-0	RW-0

**Table 62. LOW\_CLAMP Register Field Descriptions**

Bit	Field	Type	Reset	Description
0:11	CLAMP_DAC_LOW	R/W	0x00	DAC Out of Range lower clamp value

**8.5.1.2.53 HIGH\_CLAMP (EEPROM Address= 0x40000038)**
**Figure 112. HIGH\_CLAMP\_LSB Register**

7	6	5	4	3	2	1	0
CLAMP_DAC_HIGH [7:0]							
RW-0	RW-0	RW-0	RW-0	RW-0	RW-0	RW-0	RW-0

**Figure 113. HIGH\_CLAMP\_MSB Register**

7	6	5	4	3	2	1	0
CLAMP_DAC_HIGH [11:8]							
RW-0	RW-0	RW-0	RW-0	RW-0	RW-0	RW-0	RW-0

**Table 63. HIGH\_CLAMP Register Field Descriptions**

Bit	Field	Type	Reset	Description
0:11	CLAMP_DAC_HIGH	R/W	0x00	DAC Out of Range higher clamp value

**8.5.1.2.54 DIAG\_BIT\_EN (EEPROM Address= 0x4000003A)**
**Figure 114. DIAG\_BIT\_EN Register**

7	6	5	4	3	2	1	0
TGAIN_UV_EN	TGAIN_OV_EN	PGAIN_UV_EN	PGAIN_OV_EN	Reserved	VINT_OV_EN	VINP_UV_EN	VINP_OV_EN
R/W-0	R/W-0	R/W-0	R/W-0	R/W-0	R/W-0	R/W-0	R/W-0

**Table 64. DIAG\_BIT\_EN Register Field Descriptions**

Bit	Field	Type	Reset	Description
0	VINP_OV_EN	R/W	0x00	1: VINP Overvoltage Diagnostic Enable
1	VINP_UV_EN	R/W	0x00	1: VINP Undervoltage Diagnostic Enable
2	VINT_OV_EN	R/W	0x00	1: VINT Overvoltage Diagnostic Enable
3		R/W	0x00	
4	PGAIN_OV_EN	R/W	0x00	1: Pressure Gain-path Overvoltage Diagnostic Enable
5	PGAIN_UV_EN	R/W	0x00	1: Pressure Gain-path Undervoltage Diagnostic Enable
6	TGAIN_OV_EN	R/W	0x00	1: Temperature Gain-path Overvoltage Diagnostic Enable
7	TGAIN_UV_EN	R/W	0x00	1: Temperature Gain-path Undervoltage Diagnostic Enable



## 9 Application and Implementation

### NOTE

Information in the following applications sections is not part of the TI component specification, and TI does not warrant its accuracy or completeness. TI's customers are responsible for determining suitability of components for their purposes. Customers should validate and test their design implementation to confirm system functionality.

### 9.1 Application Information

The PGA302 device must be paired with an external sensor, and can be used in a variety of applications depending on the chosen sensor. When choosing a sensor, the most important consideration is to ensure that the voltages applied to the analog input pins on the PGA302 stay within the recommended operating range of 0.2 V minimum and 4.2 V maximum. A programmable gain stage allows a wide selection of sensors to be used while still maximizing the input range of the 16-Bit ADC. The PGA302's internally regulated bridge voltage supply and independent current source for temperature sensors eliminates the need for externally excited sensors. The interface options include I<sup>2</sup>C and OWI.

#### 9.1.1 0-5V Voltage Output

The 0-5V Analog Output application presents the default PGA302 device in a typical application scenario used as a part of a Sensor Transmitter system.

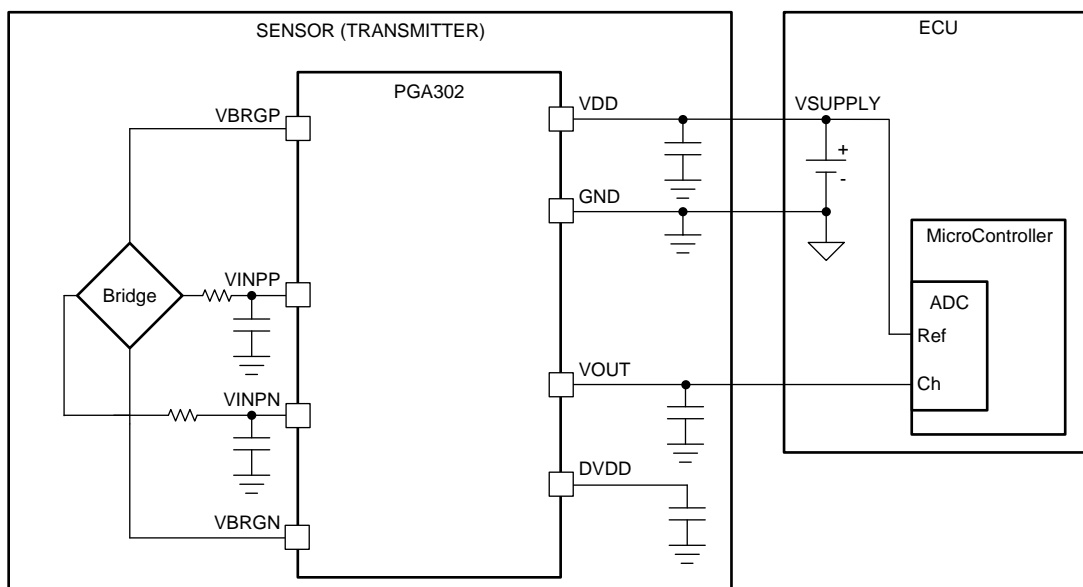

Copyright © 2017, Texas Instruments Incorporated

Figure 115. 0-5V Voltage Output

## 9.2 Typical Application

Figure 116 shows the schematic for a resistive bridge pressure-sensing application.

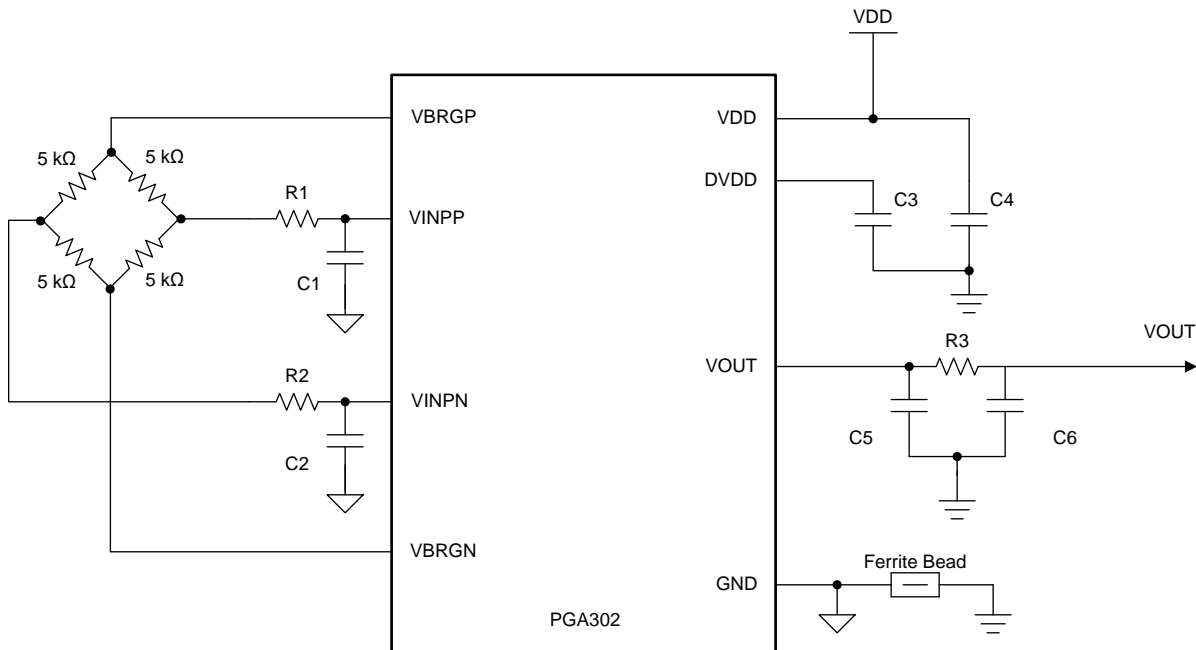

Figure 116. Application Schematic

### 9.2.1 Design Requirements

For this design example, use the parameters listed in Table 65 as the input parameters.

Table 65. Design Parameters

DESIGN PARAMETER	EXAMPLE VALUE
Input voltage range (VDD)	4.5 V to 5.5 V
Input voltage recommended	5 V
Bridge excitation voltage	2.5 V
Input mode	Differential
VINPP and VINPN voltage range	0.2 V to 4.2 V
VINPP and VINPN voltage range	5 kΩ

## 9.2.2 Detailed Design Procedure

Table 66 shows the recommended component values for the design shown in Figure 116.

**Table 66. Recommended Component Values for Typical Applications**

DESIGNATOR	VALUE	COMMENT
VINPP resistor (R1) VINPN resistor (R2)	0 Ω	These resistors are in place to determine the cutoff frequency of the lowpass filter created by R1/R2 and C1/C2. When using a resistive bridge these resistors should be 0 Ω (not used) and C1/C2 are calculated based on the bridge resistance.
VINPP capacitor (C1)	0.15 μF	$f_c(-3\text{dB}) = \frac{1}{2 \times \pi \times C_1 \times R_1}$ [Hz] Place as close to the VINPP pin as possible.
VINPN capacitor (C2)	0.15 μF	$f_c(-3\text{dB}) = \frac{1}{2 \times \pi \times C_2 \times R_2}$ [Hz] Place as close to the VINPN pin as possible.
VDD capacitor (C4)	0.1 μF	Place as close to the VDD pin as possible.
DVDD capacitor (C3)	0.1 μF	Place as close to the DVDD pin as possible.

To make use of the full range of the internal ADC it is important to carefully select the sensor to be paired with the PGA302. While the input pins can handle between 0.2 V and 4.2 V, it is good practice to make sure that the common-mode voltage of the sensor remains in middle of this range for differential signals. Note that the P Gain amplifier can be configured to measure half-bridge output, where the half bridge is connected to either VINPP or VINPN, and the remaining pin is internally connected to a voltage of VBRG/2.

To achieve the best performance, take the differential voltage range of the sensor into account. Using proper calibration with a digital compensation algorithm, any voltage range can be mapped to the full range of ADC output values, but the final measurement accuracy will be the highest if the analog voltage input matches the ADC's input range. The gain of the P Gain amplifier can be selected from 1.33 V/V to 200 V/V to aid in matching the input range of the ADC from –2.5 V to 2.5 V.

### 9.2.2.1 Application Data

Following is application data measured from a PGA302EVM-037 board. The PGA302 device has been used and was calibrated with three pressure points at one temperature (3P1T) using a resistive bridge emulator board with a schematic as pictured in Figure 117.

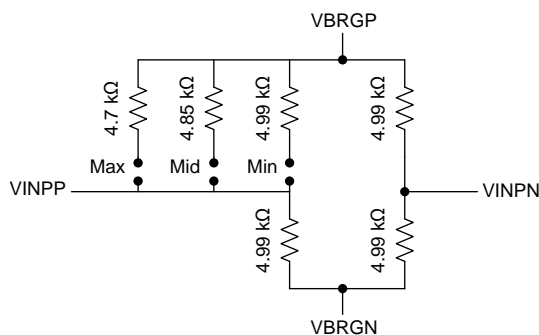

**Figure 117. Resistive Bridge Emulator Schematic**

For setup, the only parameter changed was to increase the PGAIN of the PGA302 device to 40 V/V. After the calibration was performed, the resulting VOUT output voltages were measured at each of the three pressure points and error was calculated based on the expected values as shown in Table 67. Error was calculated using the formula  $((V_{OUT} \text{ measured} - V_{OUT} \text{ Expected})/V_{OUT} \text{ range}) \times 100$  to account for the expected output range.

**Table 67. 3P1T Calibration Accuracy**

CALIBRATION POINT	VDD (V)	VINPP - VINPN (mV)	VOUT MEASURED (V)	VOUT EXPECTED (V)	ERROR (%FSR)
P1	4.8642	34.651	0.503	0.5	0.075
P2	4.8602	13.844	2.501	2.5	0.025
P3	4.8589	1.608	4.498	4.5	-0.05%

Additional testing was also done with varying calibration points of 3P3T and 4P4T to show accuracy data across temperature. [Table 68](#) includes 3P3T and 4P4T data at the P2 (2.5-V VOUT) pressure point only. The experimental setup is identical to that used to produce the 3P1T data shown in [Table 67](#) with the exception of the resistive bridge emulator which includes an extra pressure point for four possible calibration points.

**Table 68. 3P3T and 4P4T Calibration Accuracy**

CALIBRATION METHOD	VOUT VOLTAGE			ERROR, %FSR		
	-40°C	50°C	150°C	-40°C	50°C	150°C
3P3T	2.494	2.503	2.502	0.0125	0.2625	0.2875
4P4T	2.495	2.501	2.502	0.0375	0.2375	0.3125

### 9.2.3 Application Curves

[Table 69](#) lists the application curves also found in the [Typical Characteristics](#) section.

**Table 69. Table of Graphs**

GRAPH TITLE	FIGURE
Internal Temperature Sensor	<a href="#">Figure 3</a>
ADE and ADC Linearity Error	<a href="#">Figure 4</a>
AFE and ADC Linearity Error	<a href="#">Figure 5</a>
DAC Linearity Error	<a href="#">Figure 6</a>
Ratiometric Error vs VDD Supply	<a href="#">Figure 7</a>
AFE Gain vs Common-Mode Input	<a href="#">Figure 8</a>

## 10 Power Supply Recommendations

The PGA302 device has a single pin, VDD, for the input power supply, and has a voltage supply range of 4.5 V to 5.5 V. The maximum slew rate for the VDD pin is 5 V/ns as specified in the [Recommended Operating Conditions](#). Faster slew rates may generate a POR. A decoupling capacitor must be placed as close as possible to the VDD pin. For OWI communication, the VDD voltage can be >5.5 V during the OWI Activation period.

## 11 Layout

### 11.1 Layout Guidelines

At minimum, a two layer board is required for a typical pressure-sensing application. PCB layers must be separated by analog and digital signals. The pin map of the device is such that the power and digital signals are on the opposite side of the analog signal pins. Best practices for PGA302 device layout are as follows:

- The analog input signal pins, VINPP, VINPN, VINTP, and VINTN are the most susceptible to noise, and must be routed as directly to the sensor as possible. Additionally, each pair of positive and negative inputs must be routed in differential pairs with matching trace length, and both traces as close together as possible throughout their length. This routing is critical in reducing EMI and offset to provide the most accurate measurements.
- TI recommended separating the grounds to reduce noise at the analog input of the device. Capacitors to ground for ESD protection on the analog input signal pins must go first to this separate ground and be as close to the pins as possible to reduce the length of the ground wire. The analog input ground can be connected to the main ground with a ferrite bead, but a copper trace, a 0-Ω resistor can be used instead.
- The decoupling capacitors for DVDD and VDD must be placed as close to the pins as possible.
- All digital communication must be routed as far away from the analog input signal pins as possible. This includes the SCL and SDA pins, as well as the VDD pin when using OWI communication.

### 11.2 Layout Example

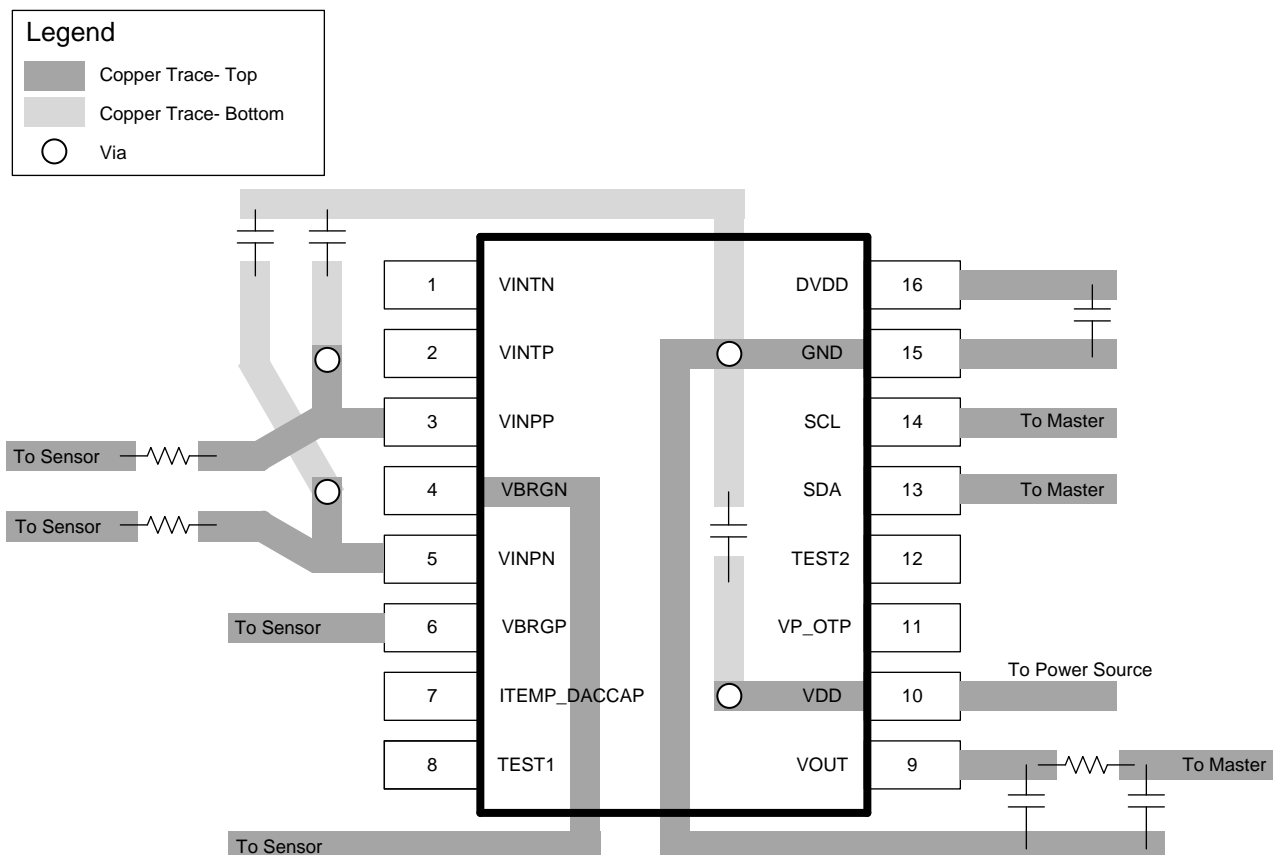

Figure 118. Layout Example

## 12 Device and Documentation Support

### 12.1 Receiving Notification of Documentation Updates

To receive notification of documentation updates, navigate to the device product folder on ti.com. In the upper right corner, click on *Alert me* to register and receive a weekly digest of any product information that has changed. For change details, review the revision history included in any revised document.

### 12.2 Community Resources

The following links connect to TI community resources. Linked contents are provided "AS IS" by the respective contributors. They do not constitute TI specifications and do not necessarily reflect TI's views; see TI's [Terms of Use](#).

**TI E2E™ Online Community** *TI's Engineer-to-Engineer (E2E) Community*. Created to foster collaboration among engineers. At e2e.ti.com, you can ask questions, share knowledge, explore ideas and help solve problems with fellow engineers.

**Design Support** *TI's Design Support* Quickly find helpful E2E forums along with design support tools and contact information for technical support.

### 12.3 Trademarks

E2E is a trademark of Texas Instruments.  
All other trademarks are the property of their respective owners.

### 12.4 Electrostatic Discharge Caution



These devices have limited built-in ESD protection. The leads should be shorted together or the device placed in conductive foam during storage or handling to prevent electrostatic damage to the MOS gates.

### 12.5 Glossary

[SLYZ022](#) — *TI Glossary*.

This glossary lists and explains terms, acronyms, and definitions.

## 13 Mechanical, Packaging, and Orderable Information

The following pages include mechanical, packaging, and orderable information. This information is the most current data available for the designated devices. This data is subject to change without notice and revision of this document. For browser-based versions of this data sheet, refer to the left-hand navigation.

**PACKAGING INFORMATION**

Orderable Device	Status (1)	Package Type	Package Drawing	Pins	Package Qty	Eco Plan (2)	Lead/Ball Finish (6)	MSL Peak Temp (3)	Op Temp (°C)	Device Marking (4/5)	Samples
PGA302EPWR	ACTIVE	TSSOP	PW	16	2000	Green (RoHS & no Sb/Br)	CU NIPDAU	Level-3-260C-168 HR	-40 to 150	PGA302	<a href="#">Samples</a>
PGA302EPWT	ACTIVE	TSSOP	PW	16	250	Green (RoHS & no Sb/Br)	CU NIPDAU	Level-3-260C-168 HR	-40 to 150	PGA302	<a href="#">Samples</a>

(1) The marketing status values are defined as follows:

**ACTIVE:** Product device recommended for new designs.

**LIFEBUY:** TI has announced that the device will be discontinued, and a lifetime-buy period is in effect.

**NRND:** Not recommended for new designs. Device is in production to support existing customers, but TI does not recommend using this part in a new design.

**PREVIEW:** Device has been announced but is not in production. Samples may or may not be available.

**OBSOLETE:** TI has discontinued the production of the device.

(2) **RoHS:** TI defines "RoHS" to mean semiconductor products that are compliant with the current EU RoHS requirements for all 10 RoHS substances, including the requirement that RoHS substance do not exceed 0.1% by weight in homogeneous materials. Where designed to be soldered at high temperatures, "RoHS" products are suitable for use in specified lead-free processes. TI may reference these types of products as "Pb-Free".

**RoHS Exempt:** TI defines "RoHS Exempt" to mean products that contain lead but are compliant with EU RoHS pursuant to a specific EU RoHS exemption.

**Green:** TI defines "Green" to mean the content of Chlorine (Cl) and Bromine (Br) based flame retardants meet JS709B low halogen requirements of <=1000ppm threshold. Antimony trioxide based flame retardants must also meet the <=1000ppm threshold requirement.

(3) MSL, Peak Temp. - The Moisture Sensitivity Level rating according to the JEDEC industry standard classifications, and peak solder temperature.

(4) There may be additional marking, which relates to the logo, the lot trace code information, or the environmental category on the device.

(5) Multiple Device Markings will be inside parentheses. Only one Device Marking contained in parentheses and separated by a "~" will appear on a device. If a line is indented then it is a continuation of the previous line and the two combined represent the entire Device Marking for that device.

(6) Lead/Ball Finish - Orderable Devices may have multiple material finish options. Finish options are separated by a vertical ruled line. Lead/Ball Finish values may wrap to two lines if the finish value exceeds the maximum column width.

**Important Information and Disclaimer:**The information provided on this page represents TI's knowledge and belief as of the date that it is provided. TI bases its knowledge and belief on information provided by third parties, and makes no representation or warranty as to the accuracy of such information. Efforts are underway to better integrate information from third parties. TI has taken and continues to take reasonable steps to provide representative and accurate information but may not have conducted destructive testing or chemical analysis on incoming materials and chemicals. TI and TI suppliers consider certain information to be proprietary, and thus CAS numbers and other limited information may not be available for release.

In no event shall TI's liability arising out of such information exceed the total purchase price of the TI part(s) at issue in this document sold by TI to Customer on an annual basis.





PW (R-PDSO-G16)

PLASTIC SMALL OUTLINE

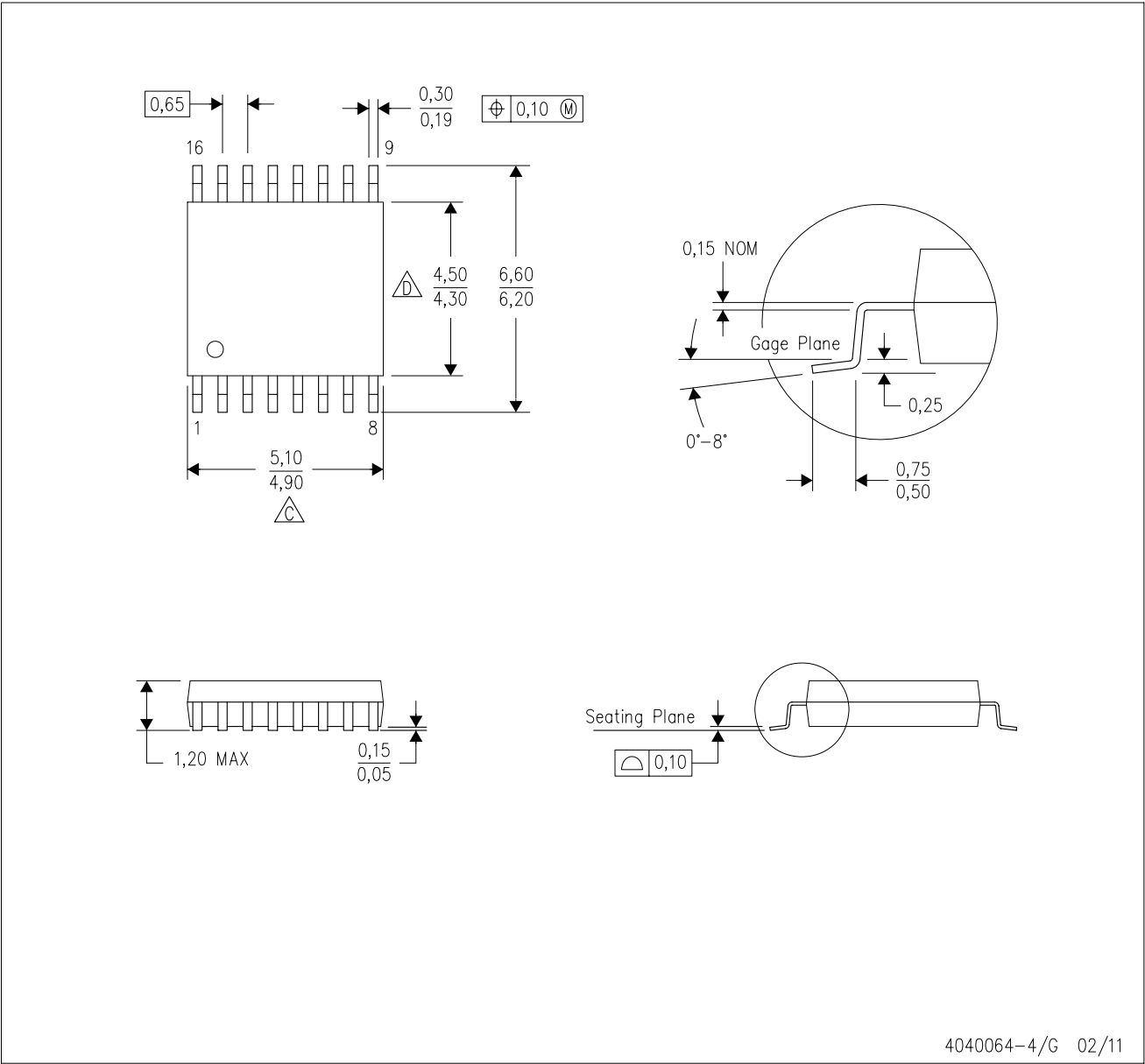

4040064-4/G 02/11

- NOTES:
- A. All linear dimensions are in millimeters. Dimensioning and tolerancing per ASME Y14.5M-1994.
  - B. This drawing is subject to change without notice.
  - C. Body length does not include mold flash, protrusions, or gate burrs. Mold flash, protrusions, or gate burrs shall not exceed 0,15 each side.
  - D. Body width does not include interlead flash. Interlead flash shall not exceed 0,25 each side.
  - E. Falls within JEDEC MO-153

## IMPORTANT NOTICE

Texas Instruments Incorporated (TI) reserves the right to make corrections, enhancements, improvements and other changes to its semiconductor products and services per JESD46, latest issue, and to discontinue any product or service per JESD48, latest issue. Buyers should obtain the latest relevant information before placing orders and should verify that such information is current and complete.

TI's published terms of sale for semiconductor products (<http://www.ti.com/sc/docs/stdterms.htm>) apply to the sale of packaged integrated circuit products that TI has qualified and released to market. Additional terms may apply to the use or sale of other types of TI products and services.

Reproduction of significant portions of TI information in TI data sheets is permissible only if reproduction is without alteration and is accompanied by all associated warranties, conditions, limitations, and notices. TI is not responsible or liable for such reproduced documentation. Information of third parties may be subject to additional restrictions. Resale of TI products or services with statements different from or beyond the parameters stated by TI for that product or service voids all express and any implied warranties for the associated TI product or service and is an unfair and deceptive business practice. TI is not responsible or liable for any such statements.

Buyers and others who are developing systems that incorporate TI products (collectively, "Designers") understand and agree that Designers remain responsible for using their independent analysis, evaluation and judgment in designing their applications and that Designers have full and exclusive responsibility to assure the safety of Designers' applications and compliance of their applications (and of all TI products used in or for Designers' applications) with all applicable regulations, laws and other applicable requirements. Designer represents that, with respect to their applications, Designer has all the necessary expertise to create and implement safeguards that (1) anticipate dangerous consequences of failures, (2) monitor failures and their consequences, and (3) lessen the likelihood of failures that might cause harm and take appropriate actions. Designer agrees that prior to using or distributing any applications that include TI products, Designer will thoroughly test such applications and the functionality of such TI products as used in such applications.

TI's provision of technical, application or other design advice, quality characterization, reliability data or other services or information, including, but not limited to, reference designs and materials relating to evaluation modules, (collectively, "TI Resources") are intended to assist designers who are developing applications that incorporate TI products; by downloading, accessing or using TI Resources in any way, Designer (individually or, if Designer is acting on behalf of a company, Designer's company) agrees to use any particular TI Resource solely for this purpose and subject to the terms of this Notice.

TI's provision of TI Resources does not expand or otherwise alter TI's applicable published warranties or warranty disclaimers for TI products, and no additional obligations or liabilities arise from TI providing such TI Resources. TI reserves the right to make corrections, enhancements, improvements and other changes to its TI Resources. TI has not conducted any testing other than that specifically described in the published documentation for a particular TI Resource.

Designer is authorized to use, copy and modify any individual TI Resource only in connection with the development of applications that include the TI product(s) identified in such TI Resource. NO OTHER LICENSE, EXPRESS OR IMPLIED, BY ESTOPPEL OR OTHERWISE TO ANY OTHER TI INTELLECTUAL PROPERTY RIGHT, AND NO LICENSE TO ANY TECHNOLOGY OR INTELLECTUAL PROPERTY RIGHT OF TI OR ANY THIRD PARTY IS GRANTED HEREIN, including but not limited to any patent right, copyright, mask work right, or other intellectual property right relating to any combination, machine, or process in which TI products or services are used. Information regarding or referencing third-party products or services does not constitute a license to use such products or services, or a warranty or endorsement thereof. Use of TI Resources may require a license from a third party under the patents or other intellectual property of the third party, or a license from TI under the patents or other intellectual property of TI.

TI RESOURCES ARE PROVIDED "AS IS" AND WITH ALL FAULTS. TI DISCLAIMS ALL OTHER WARRANTIES OR REPRESENTATIONS, EXPRESS OR IMPLIED, REGARDING RESOURCES OR USE THEREOF, INCLUDING BUT NOT LIMITED TO ACCURACY OR COMPLETENESS, TITLE, ANY EPIDEMIC FAILURE WARRANTY AND ANY IMPLIED WARRANTIES OF MERCHANTABILITY, FITNESS FOR A PARTICULAR PURPOSE, AND NON-INFRINGEMENT OF ANY THIRD PARTY INTELLECTUAL PROPERTY RIGHTS. TI SHALL NOT BE LIABLE FOR AND SHALL NOT DEFEND OR INDEMNIFY DESIGNER AGAINST ANY CLAIM, INCLUDING BUT NOT LIMITED TO ANY INFRINGEMENT CLAIM THAT RELATES TO OR IS BASED ON ANY COMBINATION OF PRODUCTS EVEN IF DESCRIBED IN TI RESOURCES OR OTHERWISE. IN NO EVENT SHALL TI BE LIABLE FOR ANY ACTUAL, DIRECT, SPECIAL, COLLATERAL, INDIRECT, PUNITIVE, INCIDENTAL, CONSEQUENTIAL OR EXEMPLARY DAMAGES IN CONNECTION WITH OR ARISING OUT OF TI RESOURCES OR USE THEREOF, AND REGARDLESS OF WHETHER TI HAS BEEN ADVISED OF THE POSSIBILITY OF SUCH DAMAGES.

Unless TI has explicitly designated an individual product as meeting the requirements of a particular industry standard (e.g., ISO/TS 16949 and ISO 26262), TI is not responsible for any failure to meet such industry standard requirements.

Where TI specifically promotes products as facilitating functional safety or as compliant with industry functional safety standards, such products are intended to help enable customers to design and create their own applications that meet applicable functional safety standards and requirements. Using products in an application does not by itself establish any safety features in the application. Designers must ensure compliance with safety-related requirements and standards applicable to their applications. Designer may not use any TI products in life-critical medical equipment unless authorized officers of the parties have executed a special contract specifically governing such use. Life-critical medical equipment is medical equipment where failure of such equipment would cause serious bodily injury or death (e.g., life support, pacemakers, defibrillators, heart pumps, neurostimulators, and implantables). Such equipment includes, without limitation, all medical devices identified by the U.S. Food and Drug Administration as Class III devices and equivalent classifications outside the U.S.

TI may expressly designate certain products as completing a particular qualification (e.g., Q100, Military Grade, or Enhanced Product). Designers agree that it has the necessary expertise to select the product with the appropriate qualification designation for their applications and that proper product selection is at Designers' own risk. Designers are solely responsible for compliance with all legal and regulatory requirements in connection with such selection.

Designer will fully indemnify TI and its representatives against any damages, costs, losses, and/or liabilities arising out of Designer's non-compliance with the terms and provisions of this Notice.