

Optical Sensor
Product Data Sheet
LTR-381RGB-WA

Spec No. :DS86-2017-0037
Effective Date: 03/03/2018
Revision: -

LITE-ON DCC

RELEASE

BNS-OD-FC001/A4

OPTICAL SENSOR LTR-381RGB-WA

Description

The LTR-381RGB-WA is an integrated low voltage I2C ambient light sensor (ALS) and a color sensor (CS) in a single 2x2mm miniature ChipLED lead-free surface mount package.

With the advanced RGB color sensor, this sensor converts light (Red, Green, Blue, and IR) intensity to a digital output signal capable of direct I2C interface. The ALS provides a linear response over a wide dynamic range, which is well suited to applications under very low or bright ambient brightness.

The sensor has a programmable interrupt with hysteresis to response to events and that removes the need to poll the sensor for a reading which improves system efficiency. This CMOS design and factory-set one time trimming capability ensure minimal sensor-to-sensor variations for ease of manufacturability to the end customers.

Application

Control brightness and color of display panel in mobile, computing, and consumer devices.

Features

- I²C interface (Standard mode @100kHz or Fast mode @400kHz)
- Ambient Light / Advanced RGB in ultra-small chipled package
- Very low power consumption with sleep mode capability
- Operating voltage ranges: 1.7V to 3.6V
- Operating temperature ranges: -40 to +85 °C
- Built-in temperature compensation circuit
- Programmable interrupt function for ALS with upper and lower thresholds
- RoHS and Halogen free compliant

- **RGB/ALS Features**
 - 16 to 20 bits effective resolution
 - Wide dynamic range with linear response
 - Close to human eye spectral response
 - Automatic rejection for 50Hz/60Hz lighting flicker

Ordering Information

Part Number	Packaging Type	Package	Quantity
LTR-381RGB-WA	Tape and Reel	6-pin chipled package	2500

Part No. : LTR-381RGB-WA
BNS-OD-FC002/A4

OPTICAL SENSOR LTR-381RGB-WA

1. Outline Dimensions

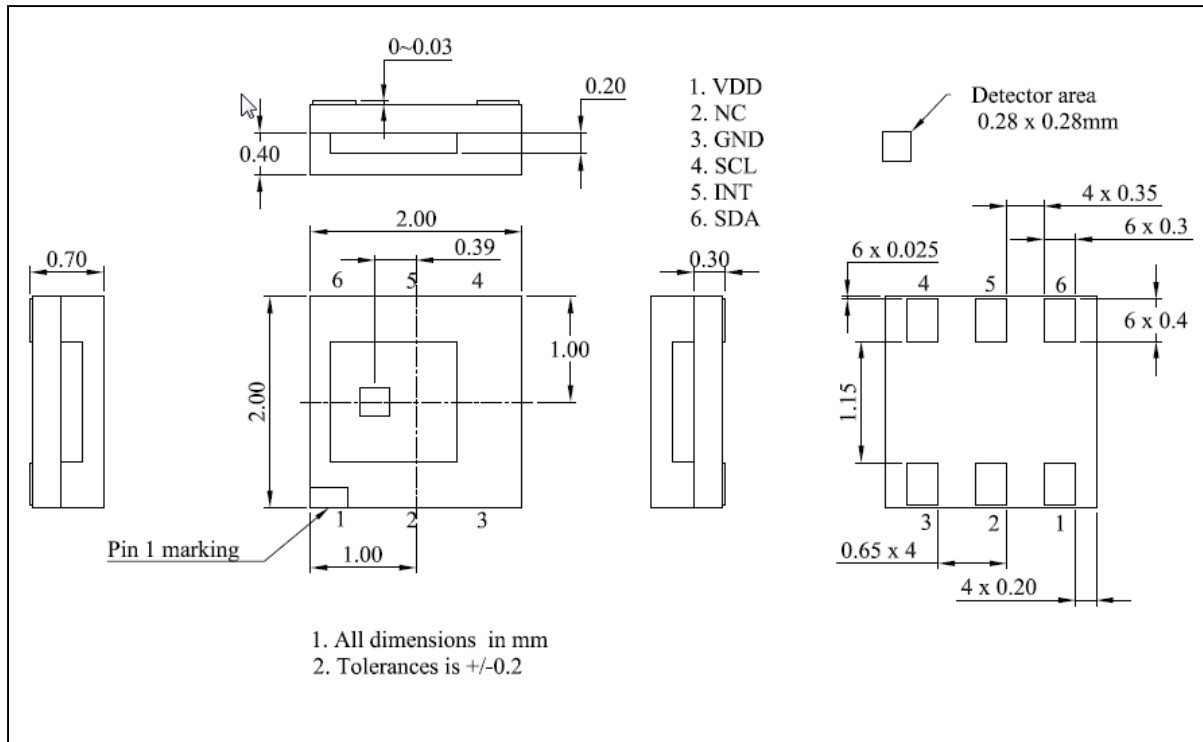

OPTICAL SENSOR LTR-381RGB-WA

2. Functional Block Diagram

LTR-381RGB-WA contains different photodiodes for ALS/CS (red, green, blue, and IR channel) measurement. The photodiode currents are converted to digital values by ADCs. The sensor also includes some peripheral circuits such as an internal oscillator, a current source, voltage reference, and internal fuses to store trimming information.

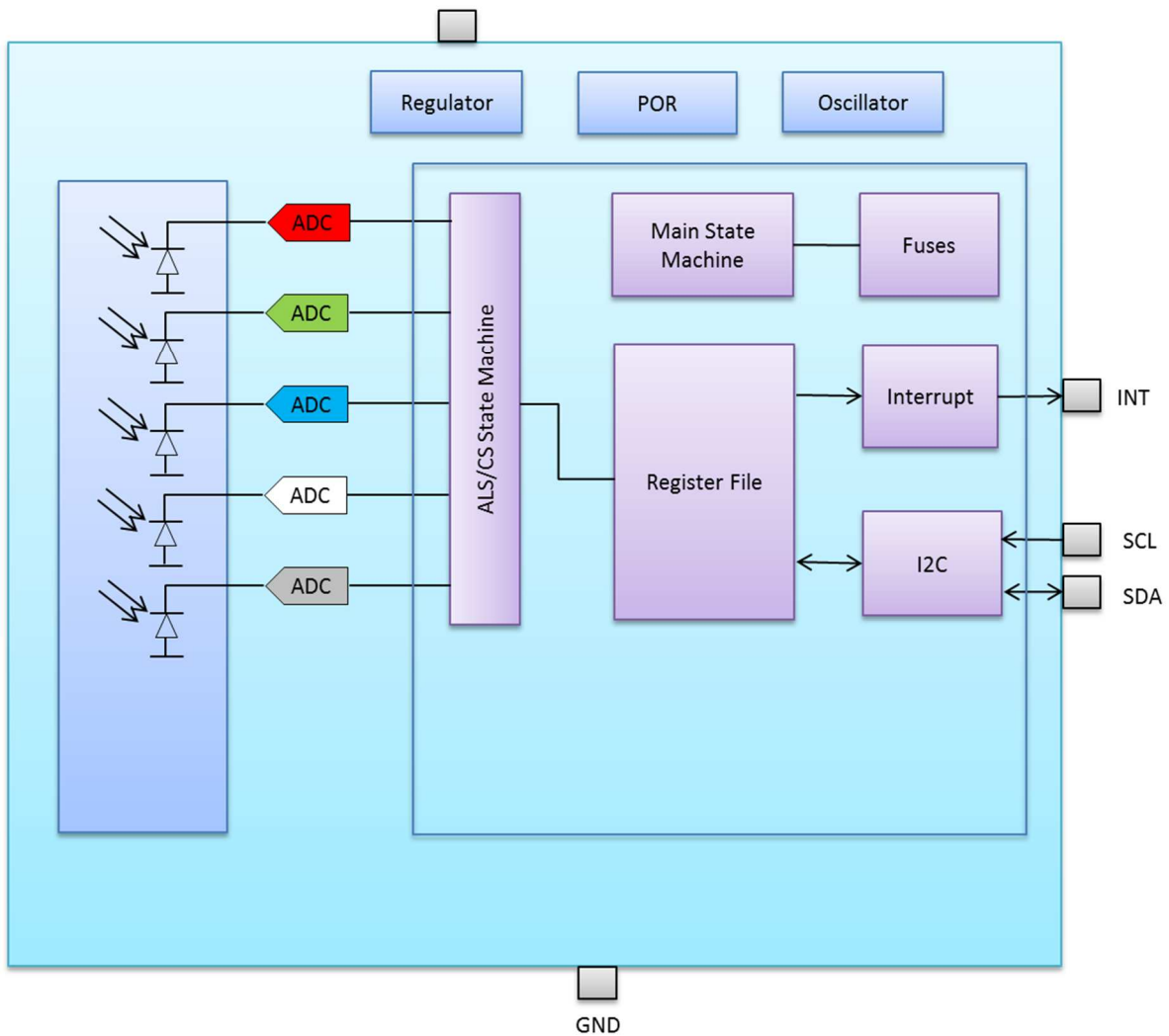

OPTICAL SENSOR LTR-381RGB-WA

3. Application Circuit

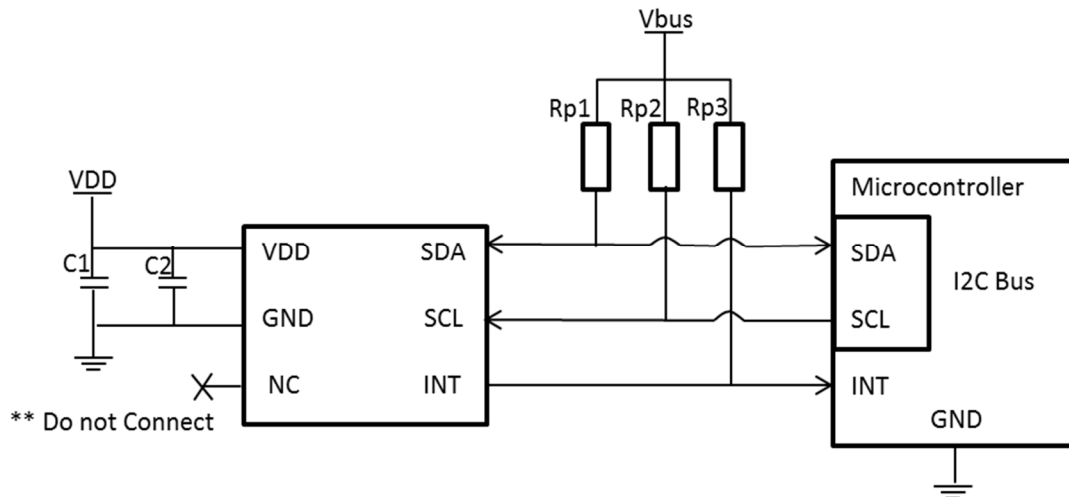

I/O Pins Configuration Table

Pin	I/O Type	Symbol	Description
1	Supply	VDD	Power Supply Voltage
2		NC	Reserved for internal test. Do not connect at application circuit level.
3	Ground	GND	Ground
4	I	SCL*	I ² C serial clock. This pin is an open drain input.
5	O	INT*	Level Interrupt Pin. This pin is an open drain output.
6	I/O	SDA*	I ² C serial data. This pin is an open drain input / output.

* Note: For noisy environment, add 10pF capacitor from signal to GND for additional noise filtering.

Recommended Application Circuit Components

Component	Recommended Value
Rp1, Rp2, Rp3 [1]	1 kΩ to 10 kΩ
C1	0.1uF
C2	1uF

Notes:

[1] Selection of pull-up resistors value is dependent on bus capacitance values. For more details, please refer to I²C Specifications: http://www.nxp.com/documents/user_manual/UM10204.pdf

OPTICAL SENSOR LTR-381RGB-WA

4. Rating and Specification

4.1. Absolute Maximum Rating at Ta=25°C

Parameter	Symbol	Min.	Max.	Unit
Supply Voltage	VDD		3.63	V
Digital Voltage Range	SCL, SDA, INT	-0.5	3.63	V
Storage Temperature	T _{stg}	-40	95	°C
Electrostatic Discharge Protection ^{Note 1} (Human Body Model JESD22-A114)	V _{HBM}	2000		V

Note:

- ESD V_{HBM} for pin 2 (NC) is 1000V. This pin is reserved for internal test, do not connect at application circuit level.
- Exceeding these ratings could cause damage to the sensor. All voltages are with respect to ground. Currents are positive into, negative out of the specified terminal.

4.2. Recommended Operating Conditions

Description	Symbol	Min.	Typ.	Max.	Unit
Supply Voltage	VDD	1.7		3.6	V
Interface signal input high	V _{I2Chigh}	1.5		VDD	V
Interface signal input low	V _{I2Clow}	0		0.4	V
Operating Temperature	T _{ope}	-40		85	°C

4.3. Electrical Specifications (VDD = 3.0V, Ta=25°C , unless otherwise noted)

Parameter	Min.	Typ.	Max.	Unit	Condition
ALS Active Supply Current		120		µA	Default duty cycle, VDD=3.0V, Gain 3x
CS Active Supply Current		120		µA	Default duty cycle, VDD=3.0V
Standby Current		1.2		µA	Standby Mode
Wakeup Time from Standby		0.5	10	ms	From Standby to Active mode where measurement can start

OPTICAL SENSOR LTR-381RGB-WA

4.4. Characteristics Ambient Light/Color Sensor (VDD = 3.0V, Ta=25°C, unless otherwise noted)

Parameter	Min.	Typ.	Max.	Unit	Condition
ALS/CS Resolution	16		20	Bit	Programmable for 16, 17, 18, 19, 20 Bit
Dark Level Count		0	5	Count	0 Lux, 18-bit resolution
Lux Accuracy	-10		+10	%	Direct illumination
Color temperature Accuracy	-5		+5	%	Based on XYZ coordinate, no window.
50/60 Hz flicker noise error	-5		+5	%	
Temperature Dependency	-0.25		+0.25	%/°C	At 100 Lux
Voltage Dependency	-5		+5	%	At 100 Lux, At operating voltage ranges
Integration time	25		400	ms	With 50/60Hz Rejection

4.5. Typical Device Parameter

(VDD = 3.0V, Ta=25°C, Default power-up settings, unless otherwise noted)

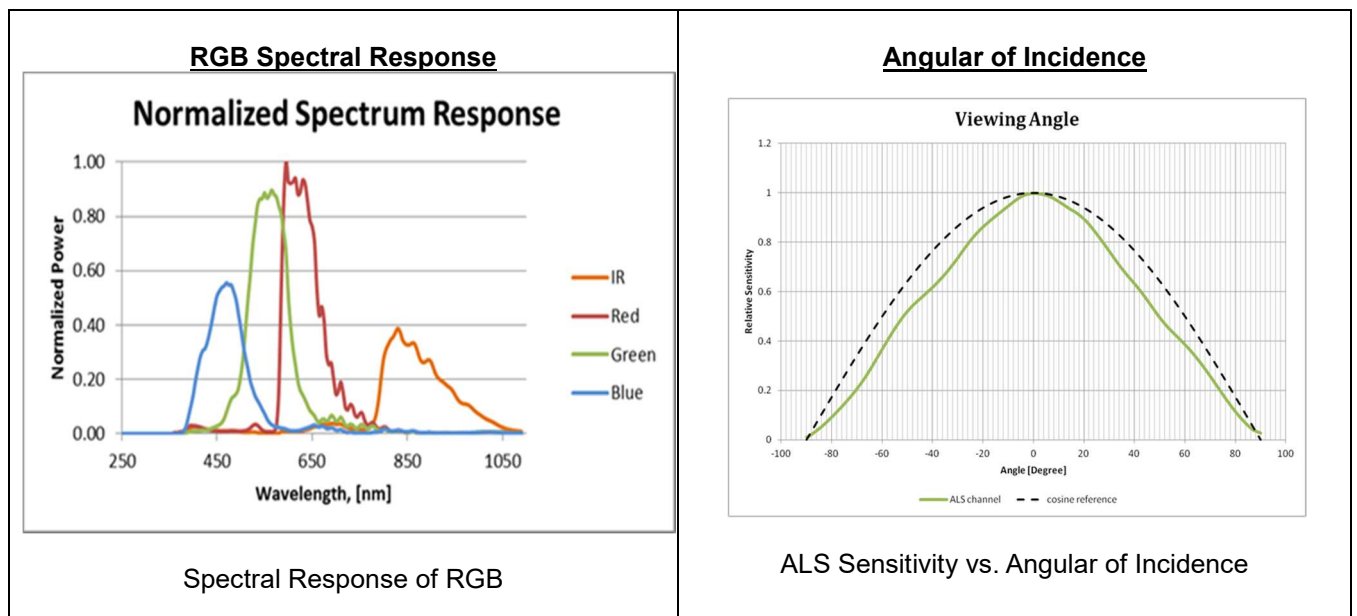

OPTICAL SENSOR LTR-381RGB-WA

4.8. AC Electrical Characteristics

All specifications are at VBus = 1.7V, T_{ope} = 25°C, unless otherwise noted.

Parameter	Symbol	Min.	Max.	Unit
SCL clock frequency	f_{SCL}	1	400	kHz
Bus free time between a STOP and START condition	t_{BUF}	1.3		us
Hold time (repeated) START condition. After this period, the first clock pulse is generated	$t_{HD;STA}$	0.6		us
LOW period of the SCL clock	t_{LOW}	1.3		us
HIGH period of the SCL clock	t_{HIGH}	0.6		us
Set-up time for a repeated START condition	$t_{SU;STA}$	0.6		us
Set-up time for STOP condition	$t_{SU;STO}$	0.6		us
Rise time of both SDA and SCL signals	t_r	30	300	ns
Fall time of both SDA and SCL signals	t_f	30	300	ns
Data hold time	$t_{HD;DAT}$	0.3	0.9	us
Data setup time	$t_{SU;DAT}$	100		ns
Pulse width of spikes which must be suppressed by the input filter	t_{SP}	0	50	ns

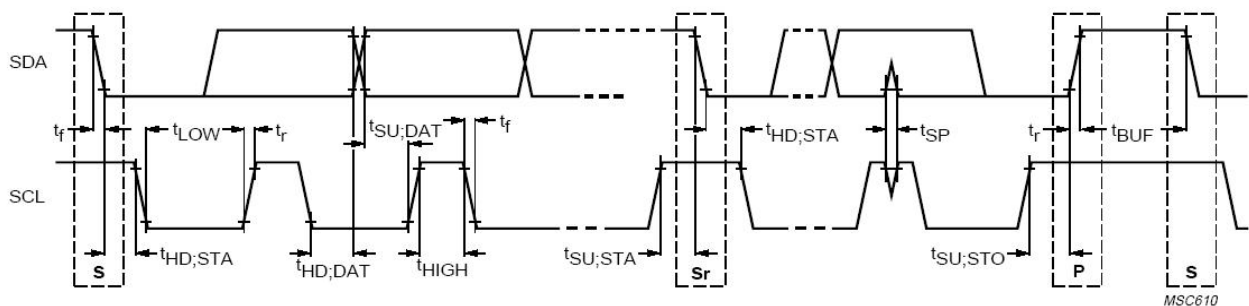

Definition of timing for I²C bus

OPTICAL SENSOR LTR-381RGB-WA

5. Principle of Operation

I²C Protocols

• I²C Write Protocol (type 1):

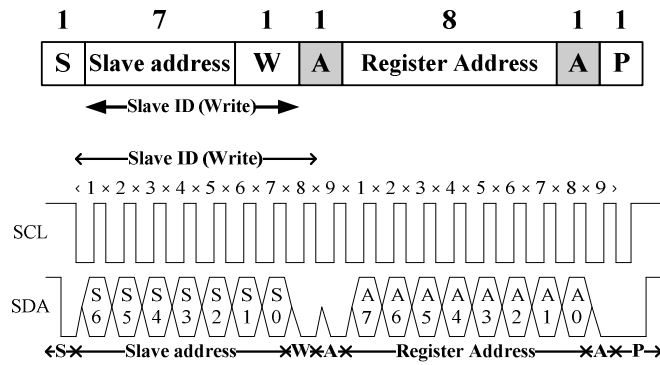

• I²C Write Protocol (type 2):

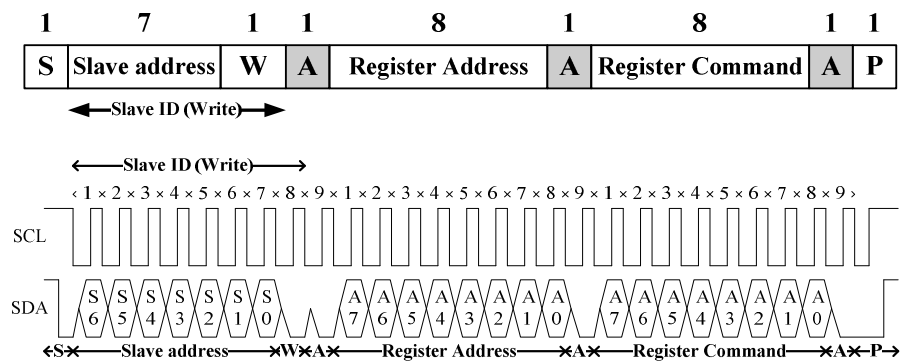

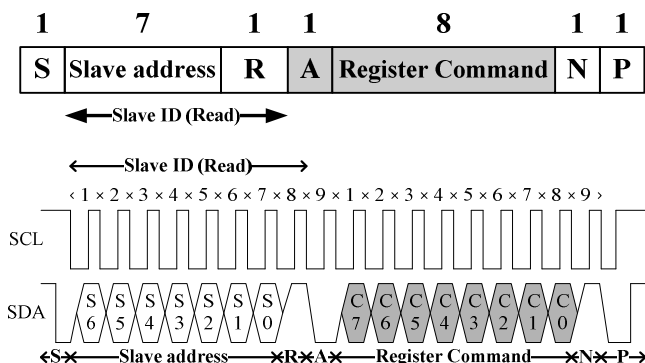

• I²C Read Protocol:

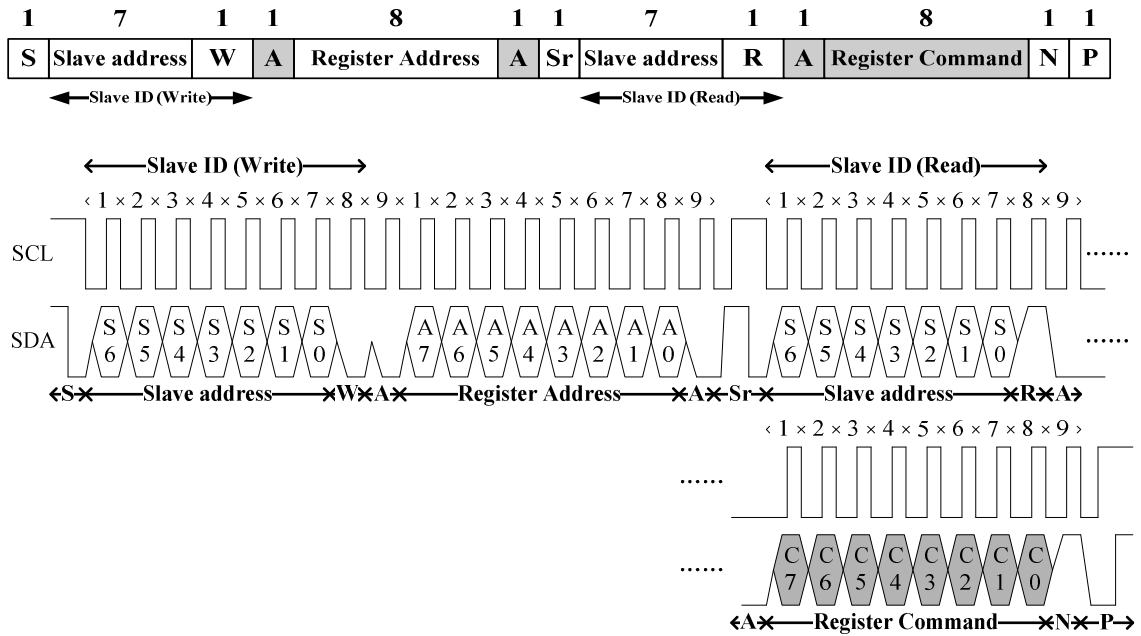

OPTICAL SENSOR LTR-381RGB-WA

I²C Read (Combined format) Protocol:



A Acknowledge (0 for an ACK)
S Start condition
P Stop condition
W Write (0 for writing)
 Slave-to-master

N Non-Acknowledge(1 for an NACK)
Sr Repeated Start condition
R Read (1 for read)
 Master-to-Slave

I²C Slave Address

The device has a 7-bit slave address of 0x53. A read/write bit should be appended to the slave address by the master device to properly communicate with the device.

I ² C Slave Address (Default)									
Command Type	(0x53)							W/R	value
	Bit 7	Bit 6	Bit 5	Bit 4	Bit 3	Bit 2	Bit 1	Bit 0	
Write	1	0	1	0	0	1	1	0	0xA6H
Read	1	0	1	0	0	1	1	1	0xA7H

OPTICAL SENSOR LTR-381RGB-WA

6. Register Set

Addr	R/W	Register Name	Description	Reset Value
0x00	R/W	MAIN_CTRL	Operation mode control, SW reset	0x00
0x01-0x03	R	Reserved	--	--
0x04	R/W	ALS_CS_MEAS_RATE	ALS/CS measurement rate and resolution in Active Mode	0x22
0x05	R/W	ALS_CS_GAIN	ALS/CS analog Gain	0x01
0x06	R	PART_ID	Part number ID and revision ID	0xC2
0x07	R	MAIN_STATUS	Power-On status, Interrupt status, Data status	0x20
0x08-0x09	R	Reserved	--	--
0x0A	R	CS_DATA_IR_0	CS IR ADC measurement data, LSB	0x00
0x0B	R	CS_DATA_IR_1	CS IR ADC measurement data	0x00
0x0C	R	CS_DATA_IR_2	CS IR ADC measurement data, MSB	0x00
0x0D	R	CS_DATA_GREEN_0	CS green / ALS ADC measurement data, LSB	0x00
0x0E	R	CS_DATA_GREEN_1	CS green / ALS ADC measurement data	0x00
0x0F	R	CS_DATA_GREEN_2	CS green / ALS ADC measurement data, MSB	0x00
0x10	R	CS_DATA_BLUE_0	CS blue ADC measurement data, LSB	0x00
0x11	R	CS_DATA_BLUE_1	CS blue ADC measurement data	0x00
0x12	R	CS_DATA_BLUE_2	CS blue ADC measurement data, MSB	0x00
0x13	R	CS_DATA_RED_0	CS red ADC measurement data, LSB	0x00
0x14	R	CS_DATA_RED_1	CS red ADC measurement data	0x00
0x15	R	CS_DATA_RED_2	CS red ADC measurement data, MSB	0x00
0x16-0x18	R	Reserved	--	--
0x19	R/W	INT_CFG	Interrupt configuration	0x10
0x1A	R/W	INT_PST	Interrupt persist setting	0x00
0x1B-0x20	R	Reserved	--	--
0x21	R/W	ALS_THRES_UP_0	ALS interrupt upper threshold, LSB	0xFF
0x22	R/W	ALS_THRES_UP_1	ALS interrupt upper threshold, intervening bits	0xFF
0x23	R/W	ALS_THRES_UP_2	ALS interrupt upper threshold, MSB	0x0F
0x24	R/W	ALS_THRES_LOW_0	ALS interrupt lower threshold, LSB	0x00
0x25	R/W	ALS_THRES_LOW_1	ALS interrupt lower threshold, intervening bits	0x00
0x26	R/W	ALS_THRES_LOW_2	ALS interrupt lower threshold, MSB	0x00

OPTICAL SENSOR LTR-381RGB-WA

MAIN_CTRL Register (0x00) (Read/Write)

This register controls the operation modes of CS/ALS, which can be set to either standby or active mode. When writing to this register, it will cause a stop to any ongoing measurements (CS/ALS) and start new measurement.

0x00	MAIN_CTRL (default = 0x00)							
	B7	B6	B5	B4	B3	B2	B1	B0
	<i>Reserved</i>			<i>SW Reset</i>	<i>Reserved</i>	<i>CS Mode</i>	<i>ALS CS Enable</i>	<i>Reserved</i>

Field	Bits	Default	Description	
Reserved	7:5	000	--	Must write 000
SW Reset	4	0	0	Software reset is NOT triggered (default)
			1	Software reset is triggered
Reserved	3	0	--	Must write 0
CS Mode	2	0	0	ALS mode: ALS, IR and Temperature Compensation Channels activated (default)
			1	CS mode: All Light Sensor channels activated (RGB+IR+COMP)
ALS/CS Enable	1	0	0	ALS standby (default)
			1	ALS active
Reserved	0	0	--	Must write 0

OPTICAL SENSOR LTR-381RGB-WA

ALS_CS_MEAS_RATE Register (0x04) (Read/Write)

This register controls ALS/CS measurement resolution, Gain setting and measurement rate. When the measurement rate is programmed to be faster than possible for the programmed ADC measurement, the rate will be lowered than programmed (maximum speed).

0x04	ALS_CS_MEAS_RATE (default = 0x22)							
	B7	B6	B5	B4	B3	B2	B1	B0
	<i>Reserved</i>	<i>ALS/CS Resolution/Bit Width</i>			<i>Reserved</i>	<i>ALS/CS Measurement Rate</i>		

Field	Bits	Default	Description	
Reserved	7	0	Must write 0	
ALS/CS Resolution	6:4	010	000	20 Bit, Conversion time = 400ms
			001	19 Bit, Conversion time = 200ms
			010	18 Bit, Conversion time = 100ms(default)
			011	17 Bit, Conversion time = 50ms
			100	16 Bit, Conversion time = 25ms
			101/110/111	Reserved
Reserved	3	0	Must write 0	
ALS/CS Measurement Rate	2:0	010	000	25ms
			001	50ms
			010	100ms (default)
			011	200ms
			100	500ms
			101	1000ms
			110/111	2000ms

OPTICAL SENSOR LTR-381RGB-WA

ALS_CS_GAIN Register (0x05) (Read/Write)

This register controls ALS/CS measurement Gain Range.

0x05	ALS_CS_GAIN (default = 0x01)							
	B7	B6	B5	B4	B3	B2	B1	B0
	<i>Reserved</i>					<i>ALS/CS Gain Range</i>		

Field	Bits	Default	Description	
Reserved	7:3	00000	Must write 00000	
ALS/CS Gain Range	2:0	001	000	Gain Range: 1
			001	Gain Range: 3 (default)
			010	Gain Range: 6
			011	Gain Range: 9
			100	Gain Range: 18

PART_ID Register (0x06) (Read Only)

This register defines the part number and revision identification of the sensor.

0x06	PART_ID (default = 0xC2)							
	B7	B6	B5	B4	B3	B2	B1	B0
	<i>Part Number ID</i>				<i>Reserved</i>			
Field	Bits	Default	Description					
Part Number ID	7:4	1100	Part Number ID					
Reserved	3:0	0010	--					

OPTICAL SENSOR LTR-381RGB-WA

MAIN_STATUS Register (0x07) (Read Only)

This register stores the information about the ALS/CS interrupts and data status. The interrupt status in Bit 4 determines if the ALS/CS interrupt criteria are met in Normal Interrupt Mode: It triggers when the CS/ALS is above the upper or below the lower threshold for a specified number of consecutive measurements in respective interrupt persist settings. For details interrupt behavior, refer to Section 10.

0x07	MAIN_STATUS (default = 0x00)							
	B7	B6	B5	B4	B3	B2	B1	B0
	<i>Reserved</i>		<i>Power ON Status</i>	<i>ALS/CS Interrupt Status</i>	<i>ALS/CS Data Status</i>	<i>Reserved</i>		

Field	Bits	Default	Description	
Reserved	7:6	00		
Power On Status	5	1	0	Normal
			1	Part went through a power-up event, either because the part was turned on or because there was a power supply voltage disturbance. A value of 1 is the default for the first register read after power-on-reset. The flag is cleared after the flag is read.
ALS/CS Interrupt Status	4	0	0	Interrupt is NOT triggered (default)
			1	Interrupt is triggered and will be cleared after read
CS/ALS Data Status	3	0	0	CS/ALS data is old data (Data has been read)
			1	CS/ALS data is new data (Data has not been read and will be cleared after read)
Reserved	2:0	000		

OPTICAL SENSOR LTR-381RGB-WA

CS_DATA_IR Register (0x0A / 0x0B / 0x0C) (Read Only)

The Color Sensor IR Channel digital output data are expressed as a 16 to 20 bit unsigned integer data. When I2C read operation is active and points to any of the register address between 0x07 and 0x18, all 3 registers will be locked until the I2C read operation has been completed or the specified address range is left. This is to ensure that the data in the registers is from the same measurement even if an additional measurement cycle ends during the read operation. New measurement data is stored into temporary registers and the CS_DATA_IR registers will be updated as soon as there is no on-going I2C read operation to the address range 0x07 to 0x18.

0x0A	CS_DATA_IR_0 (default = 0x00)							
	B7	B6	B5	B4	B3	B2	B1	B0
	<i>CS DATA IR, Low</i>							

0x0B	CS_DATA_IR_1 (default = 0x00)							
	B7	B6	B5	B4	B3	B2	B1	B0
	<i>CS DATA IR, Middle</i>							

0x0C	CS_DATA_IR_2 (default = 0x00)							
	B7	B6	B5	B4	B3	B2	B1	B0
	<i>Reserved</i>				<i>CS DATA IR, High</i>			

Field	Address	Bits	Default	Description
CS Data IR, Low	0x0A	7:0	0000 0000	CS Data (IR) lower byte data
CS Data IR, Middle	0x0B	7:0	0000 0000	CS Data (IR) Middle byte data
CS Data IR, High	0x0C	7:4	0000	Reserved
		3:0	0000	CS Data (IR) Higher byte data

OPTICAL SENSOR LTR-381RGB-WA

CS_DATA_GREEN Register (0x0D / 0x0E / 0x0F) (Read Only)

The Color Sensor Green Channel digital output data are expressed as a 16 to 20 bit unsigned integer data. When I2C read operation is active and points to any of the register address between 0x07 and 0x18, all 3 registers will be locked until the I2C read operation has been completed or the specified address range is left. This is to ensure that the data in the registers is from the same measurement even if an additional measurement cycle ends during the read operation. New measurement data is stored into temporary registers and the CS_DATA_GREEN registers will be updated as soon as there is no on-going I2C read operation to the address range 0x07 to 0x18.

0x0D	CS_DATA_GREEN_0 (default = 0x00)							
	B7	B6	B5	B4	B3	B2	B1	B0
	<i>CS DATA GREEN, Low</i>							

0x0E	CS_DATA_GREEN_1 (default = 0x00)							
	B7	B6	B5	B4	B3	B2	B1	B0
	<i>CS DATA GREEN, Middle</i>							

0x0F	CS_DATA_GREEN_2 (default = 0x00)							
	B7	B6	B5	B4	B3	B2	B1	B0
	<i>Reserved</i>				<i>CS DATA GREEN, High</i>			

Field	Address	Bits	Default	Description
CS Data Green, Low	0x0D	7:0	0000 0000	CS Data (Green) lower byte data
CS Data Green, Middle	0x0E	7:0	0000 0000	CS Data (Green) Middle byte data
CS Data Green, High	0x0F	7:4	0000	Reserved
		3:0	0000	CS Data (Green) Higher byte data

OPTICAL SENSOR LTR-381RGB-WA

CS_DATA_BLUE Register (0x10 / 0x11 / 0x12) (Read Only)

The Color Sensor Blue Channel digital output data are expressed as a 16 to 20 bit unsigned integer data. When I2C read operation is active and points to any of the register address between 0x07 and 0x18, all 3 registers will be locked until the I2C read operation has been completed or the specified address range is left. This is to ensure that the data in the registers is from the same measurement even if an additional measurement cycle ends during the read operation. New measurement data is stored into temporary registers and the CS_DATA_BLUE registers will be updated as soon as there is no on-going I2C read operation to the address range 0x07 to 0x18.

0x10	CS_DATA_BLUE_0 (default = 0x00)							
	B7	B6	B5	B4	B3	B2	B1	B0
	<i>CS DATA BLUE, Low</i>							
0x11	CS_DATA_BLUE_1 (default = 0x00)							
	B7	B6	B5	B4	B3	B2	B1	B0
	<i>CS DATA BLUE, Middle</i>							

0x12	CS_DATA_BLUE_2 (default = 0x00)							
	B7	B6	B5	B4	B3	B2	B1	B0
	<i>Reserved</i>				<i>CS DATA BLUE, High</i>			

Field	Address	Bits	Default	Description
CS Data Blue, Low	0x10	7:0	0000 0000	CS Data (Blue) lower byte data
CS Data Blue, Middle	0x11	7:0	0000 0000	CS Data (Blue) Middle byte data
CS Data Blue, High	0x12	7:4	0000	Reserved
		3:0	0000	CS Data (Blue) Higher byte data

OPTICAL SENSOR LTR-381RGB-WA

CS_DATA_RED Register (0x13 / 0x14 / 0x15) (Read Only)

The Color Sensor Red Channel digital output data are expressed as a 16 to 20 bit unsigned integer data. When I2C read operation is active and points to any of the register address between 0x07 and 0x18, all 3 registers will be locked until the I2C read operation has been completed or the specified address range is left. This is to ensure that the data in the registers is from the same measurement even if an additional measurement cycle ends during the read operation. New measurement data is stored into temporary registers and the CS_DATA_RED registers will be updated as soon as there is no on-going I2C read operation to the address range 0x07 to 0x18.

0x13	CS_DATA_RED_0 (default = 0x00)							
	B7	B6	B5	B4	B3	B2	B1	B0
	<i>CS DATA RED, Low</i>							

0x14	CS_DATA_RED_1 (default = 0x00)							
	B7	B6	B5	B4	B3	B2	B1	B0
	<i>CS DATA RED, Middle</i>							

0x15	CS_DATA_RED_2 (default = 0x00)							
	B7	B6	B5	B4	B3	B2	B1	B0
	<i>Reserved</i>				<i>CS DATA RED, High</i>			

Field	Address	Bits	Default	Description
CS Data Red, Low	0x13	7:0	0000 0000	CS Data (Red) lower byte data
CS Data Red, Middle	0x14	7:0	0000 0000	CS Data (Red) Middle byte data
CS Data Red, High	0x15	7:4	0000	Reserved
		3:0	0000	CS Data (Red) Higher byte data

OPTICAL SENSOR LTR-381RGB-WA

INT_CFG Register (0x19) (Read/Write)

This register controls the operation of the interrupt pin and functions. CS/ALS has independent interrupt signal and CS/ALS interrupt is active low. CS/ALS interrupt is enabled by Bit 2.

0x19	INT_CFG (default = 0x10)							
	B7	B6	B5	B4	B3	B2	B1	B0
	Reserved		ALS INT SELECT		Reserved	ALS INT PIN ENABLE	Reserved	

Field	Bits	Default	Description	
Reserved	7:6	00	Must write 00	
ALS Interrupt Select	4:5	01	00	IR Channel
			01	ALS/Green Channel(default)
			10	Red Channel
			11	Blue Channel
Reserved	3	0	Must write 0	
ALS Interrupt Pin Enable	2	0	0	ALS interrupt disabled (default)
			1	ALS interrupt enabled
Reserved	1:0	00	Must write 00	

OPTICAL SENSOR LTR-381RGB-WA

INT_PST Register (0x1A) (Read/Write)

This register controls the N number of times the measurement data is outside the range defined by the upper and lower threshold limits before asserting the interrupt.

0x1A	INT_PST (default = 0x00)							
	B7	B6	B5	B4	B3	B2	B1	B0
	<i>ALS/CS Persist</i>				<i>Reserved</i>			

Field	Bits	Default	Description	
ALS/CS Persist	7:4	0000	0000	Every ALS value out of threshold range asserts an interrupt (default)
			0001	2 consecutive ALS values out of threshold range assert an interrupt
		
			1111	16 consecutive ALS values out of threshold range assert an interrupt
Reserved	3:0	0000	0000	Must write 0000

OPTICAL SENSOR LTR-381RGB-WA

ALS_THRES Register (0x21 / 0x22 / 0x23 / 0x24 / 0x25 / 0x26) (Read/Write)

The ALS_THRES_UP (up to 20-bits) and ALS_THRES_LOW (up to 20-bits) registers determines the upper and lower limit of the interrupt threshold value respectively. Interrupt will be triggered if measurement data in CS_DATA_GREEN registers is exceeding the upper and lower limits.

0x21	ALS_THRES_UP_0 (default = 0xFF)							
	B7	B6	B5	B4	B3	B2	B1	B0
	ALS Upper Threshold, Low							

0x22	ALS_THRES_UP_1 (default = 0xFF)							
	B7	B6	B5	B4	B3	B2	B1	B0
	ALS Upper Threshold, Mid							

0x23	ALS_THRES_UP_2 (default = 0x0F)							
	B7	B6	B5	B4	B3	B2	B1	B0
	Reserved				ALS Upper Threshold, High			

0x24	ALS_THRES_LOW_0 (default = 0x00)							
	B7	B6	B5	B4	B3	B2	B1	B0
	ALS Lower Threshold, Low							

0x25	ALS_THRES_LOW_1 (default = 0x00)							
	B7	B6	B5	B4	B3	B2	B1	B0
	ALS Lower Threshold, Mid							

0x26	ALS_THRES_LOW_2 (default = 0x00)							
	B7	B6	B5	B4	B3	B2	B1	B0
	Reserved				ALS Lower Threshold, High			

Field	Address	Bits	Default	Description
ALS Upper Threshold, Low	0x21	7:0	1111 1111	ALS upper interrupt threshold, Low byte
ALS Upper Threshold, Mid	0x22	7:0	1111 1111	ALS upper interrupt threshold, Mid byte

**OPTICAL SENSOR
LTR-381RGB-WA**

ALS Upper Threshold, High	0x23	7:4	0000	Reserved
		3:0	1111	ALS upper interrupt threshold, High byte
ALS Lower Threshold, Low	0x24	7:0	0000 0000	ALS lower interrupt threshold, Low byte
ALS Lower Threshold, Mid	0x25	7:0	0000 0000	ALS lower interrupt threshold, Mid byte
ALS Lower Threshold, High	0x26	7:4	0000	Reserved
		3:0	0000	ALS lower interrupt threshold, High byte

OPTICAL SENSOR LTR-381RGB-WA

7 Application Information

7.1. Lux Formula

Lux_Calc is the calculated lux reading based on the output ADC from ALS DATA regardless of light sources.

$$Lux_{Calc} = \frac{0.74 \times CS_{Green_DATA}}{(GAIN \times INT)} \times \left[1 - C_1 \left(\frac{CS_{IR_DATA}}{CS_{Green_DATA}} \right) \right] \times W_{FAC}$$

Where :

1. CS_Green_DATA = Data stored in the registers (Address: 0x0D-0x0F)
2. CS_IR_DATA = Data stored in the registers (Address: 0x0A-0x0C)
3. C₁ = 0.033 constant coefficient.
4. For device under tinted window with coated-ink of flat transmission rate at 400-600nm wavelength, window factor is to compensate light loss due to the lower transmission rate from the coated-ink.
 - a. WFAC = 1 for NO window / clear window glass.
 - b. WFAC >1 device under tinted window glass. Calibrate under white LED.
5. The Gain factors & Integration time factors:

ALS Gain	GAIN
X1	1
X3	3
X6	6
X9	9
X18	18

Resolution (bit) / Integration Time (ms)	INT
16-bit, 25ms	0.25
17-bit, 50ms	0.5
18-bit, 100ms	1
19-bit, 200ms	2
20-bit, 400ms	4

OPTICAL SENSOR LTR-381RGB-WA

7.2 Device Operation (State Machine and Interrupt Features)

State Machine

Below diagram is the main state machine of LTR-381RGB-WA.

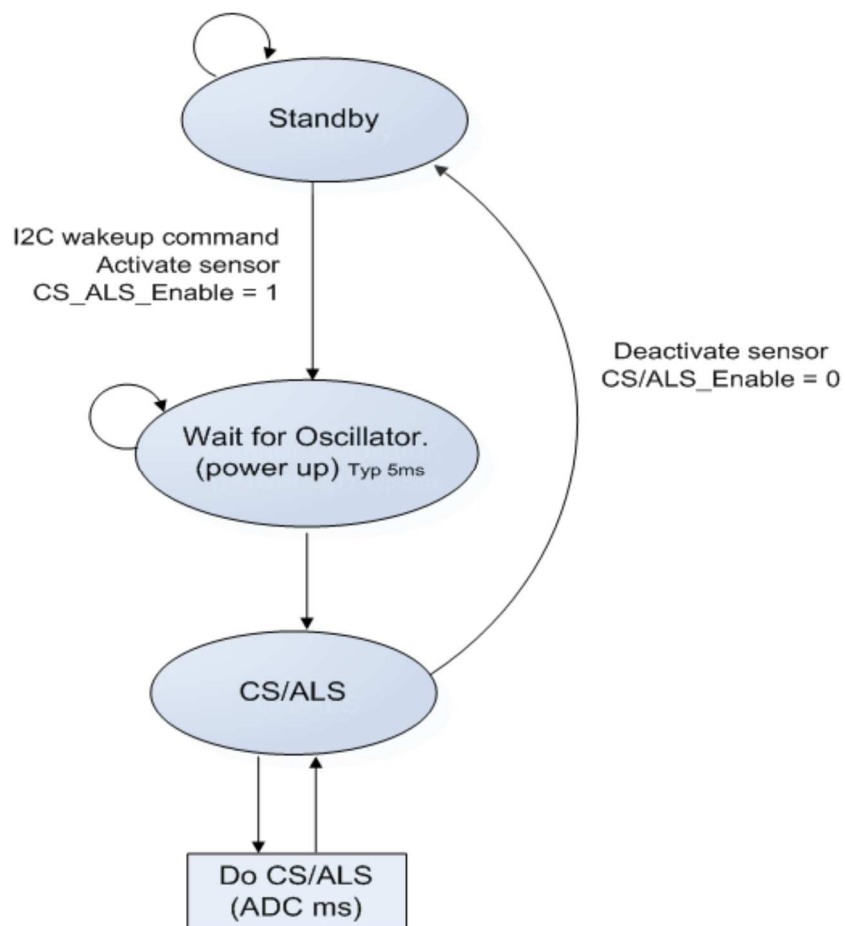

During the CS/ALS Operation, CS/ALS measurements can be activated by setting the CS_ALS_Enable bit to 1. As soon as the CS/ALS sensors become activated through an I2C command, the internal support blocks are powered on. Once the voltages and currents are settled (typically after 5ms), the state machine checks for trigger events from a measurement scheduler to start CS/ALS conversions according to the selected measurement repeat rates. Once CS_ALS_Enable is changed back to 0, a running conversion on the respective channel will be completed and the relevant ADCs and support blocks will move to power-down state.

OPTICAL SENSOR LTR-381RGB-WA

Interrupt Features

This device generates independent ALS/CS interrupt signal that can be multiplexed and output to the INT output pin. The interrupt conditions are always evaluated after completion of a new conversion of the ALS channels. ALS/CS interrupts is active low at the INT pin.

ALS/CS Interrupt

The ALS/CS interrupt is enabled by Bit 2 (ALS INT Pin Enabled) of INT_CFG register (0x19). The ALS/CS interrupt source can be any of the four CS channels (R, G, B and IR). The source is selected by Bit 4 and 5 (ALS INT Select) of INT_CFG register.

The INT is set when the data of the selected interrupt source is above the upper or below the lower threshold for a specified number of consecutive measurements set in ALS/CS Persist in INT_PST register (0x1A).

The Interrupt signal is also stored in MAIN_STATUS register (0x07) as flag bit in Bit 4 (ALS/CS INT Status). This status flag bit is cleared by reading the MAIN_STATUS register. A cleared flag will also clear the interrupt signal on the INT pin.

OPTICAL SENSOR LTR-381RGB-WA

8 Pseudo Codes Examples

MAIN_CTRL Register

// This defines the operating modes of the CS/ALS
// Default settings is 0x00 (CS Mode = ALS, ALS/CS standby)

```
Register_Addr = 0x00           // MAIN_CTRL register
Command = 0x06                // ALS in Active Mode, CS mode = CS
WriteByte(Slave_Addr, Register_Addr, Command);
```

ALS_CS_MEAS_RATE Register

// This controls the ALS/CS measurement resolution and measurement rate.
// Default setting of the register is 0x22 (Resolution = 18 Bit, Measurement rate of 100ms)

```
Register_Addr = 0x04           // ALS_CS_MEAS_RATE register
Command = 0x41                // Resolution = 16 bit, Meas Rate =50ms
                                // Command =0x25,Resolution = 18 bit, Meas Rate =1000ms
                                // Command =0x02, Resolution = 20 bit, Meas Rate =100ms
WriteByte(Slave_Addr, Register_Addr, Command)
```

ALS_CS_GAIN Register

// This controls the ALS/CS Gain Range.
// Default setting of the register is 0x01 (Gain Range = 3)

```
Register_Addr = 0x05           // ALS_CS_GAIN register
Command = 0x00                // Gain = 1
                                // Command =0x04, Gain = 18
WriteByte(Slave_Addr, Register_Addr, Command)
```

MAIN_STATUS Register (Read Only)

// This Register contains the information on Interrupt, ALS/CS data status.

```
Register_Addr = 0x07           // MAIN_STATUS register address
Data = ReadByte(Slave_Addr, Register_Addr)

Power_ON_Status = Data & 0x20 // If 0x20 Part went through power-up event
                                // If 0x00 Normal
ALS/CS_Interrupt_Status = Data & 0x10 // If 0x10 Interrupt triggered
                                // If 0x00 Interrupt condition not fulfilled
ALS/CS_Data_Status = Data & 0x08 // If 0x08 ALS/CS data is new
                                // If 0x00 Old (previously read) Data
```

CS_DATA_IR Registers (Read Only)

//The register 0x0A contains CS_IR ADC lower byte data.
//The register 0x0B contains CS_IR ADC 1 middle byte data.
//The register 0x0C contains CS_IR ADC 2 upper byte data.
//These registers should be read as a group, with the lower address being read first.

```
Register_Addr = 0x0A           // CS_DATA_IR_0 low byte address
Data0=ReadByte(Slave_Addr, Register_Addr)
Register_Addr = 0x0B           // CS_DATA_IR_1 middle byte address
Data1=ReadByte(Slave_Addr, Register_Addr)
Register_Addr = 0x0C           // CS_DATA_IR_2 upper byte address
Data2=ReadByte(Slave_Addr, Register_Addr)
```

OPTICAL SENSOR LTR-381RGB-WA

CS_IR_Data =(Data2<<16)| (Data1 << 8) | Data0 // Shift and combine all register data to get CS_IR ADC Data

CS_DATA_GREEN Registers (Read Only)

// The register 0x0D contains CS_GREEN ADC lower byte data.
 // The register 0x0E contains CS_GREEN ADC 1 upper byte data.
 // The register 0x0F contains CS_GREEN ADC 2 (top) upper byte data.
 // These registers should be read as a group, with the lower address being read first.

Register_Addr = 0x0D // CS_DATA_GREEN_0 low byte address
 Data0=ReadByte(Slave_Addr, Register_Addr)
 Register_Addr = 0x0E // CS_DATA_GREEN_1 middle byte address
 Data1=ReadByte(Slave_Addr, Register_Addr)
 Register_Addr = 0x0F // CS_DATA_GREEN_2 upper byte address
 Data2=ReadByte(Slave_Addr, Register_Addr)
 CS_GREEN_ADC_Data =(Data2<<16)| (Data1 << 8) | Data0
 // Shift and combine all registers to get CS_GREEN ADC Data

CS_DATA_BLUE Registers (Read Only)

// The register 0x10 contains CS_BLUE ADC lower byte data.
 // The register 0x11 contains CS_BLUE ADC 1 upper byte data.
 // The register 0x12 contains CS_BLUE ADC 2 (top) upper byte data.
 // These registers should be read as a group, with the lower address being read first.

Register_Addr = 0x10 // CS_DATA_BLUE_0 low byte address
 Data0=ReadByte(Slave_Addr, Register_Addr)
 Register_Addr = 0x11 // CS_DATA_BLUE_1 middle byte address
 Data1=ReadByte(Slave_Addr, Register_Addr)
 Register_Addr = 0x12 // CS_DATA_BLUE_2 upper byte address
 Data2=ReadByte(Slave_Addr, Register_Addr)
 CS_BLUE_ADC_Data =(Data2<<16)| (Data1 << 8) | Data0
 // Shift and combine all registers to get CS_BLUE ADC Data

CS_DATA_RED Registers (Read Only)

//The register 0x13 contains CS_RED ADC lower byte data.
 //The register 0x14 contains CS_RED ADC 1 upper byte data.
 //The register 0x15 contains CS_RED ADC 2 (top) upper byte data.
 //These registers should be read as a group, with the lower address being read first.

Register_Addr = 0x13 // CS_DATA_RED_0 low byte address
 Data0=ReadByte(Slave_Addr, Register_Addr)
 Register_Addr = 0x14 // CS_DATA_RED_1 middle byte address
 Data1=ReadByte(Slave_Addr, Register_Addr)
 Register_Addr = 0x15 // CS_DATA_RED_2 upper byte address
 Data2=ReadByte(Slave_Addr, Register_Addr)
 CS_RED_ADC_Data =(Data2<<16)| (Data1 << 8) | Data0
 // Shift and combine all registers to get CS_RED ADC Data

INT_CFG Register

//This register controls the operation of the interrupt pins and options to trigger interrupt for ALS/CS.
 //The default value for this INT_CFG register is 0x10 (Interrupts inactive for both ALS/CS)

Register_Addr = 0x19 // INT_CFG Register address
 Command = 0x14 // Interrupt CH = ALS, ALS Interrupt Enable, Normal trigger mode.

WriteByte(Slave_Addr, Register_Addr, Command)

OPTICAL SENSOR LTR-381RGB-WA

INTERRUPT_PERSIST Register

// This register sets the ALS/CS persist level.
// The default setting is 0x00. Interrupt at every ALS/CS reading outside set thresholds.

```
Register_Addr = 0x1A           // INT_PST register
Command = 0x00                // Interrupt for every ALS outside threshold
                               // Command =0x10           Subsequent 2 ALS outside threshold range
                               // Command =0x30           Subsequent 4 ALS outside threshold range
```

WriteByte(Slave_Addr, Register_Addr, Command)

ALS_THRES Registers

//The register 0x21 contains CS/ALS Interrupt upper threshold lower byte data (ALS_THRES_UP_0)
//The register 0x22 contains CS/ALS Interrupt upper threshold 1 upper byte data (ALS_THRES_UP_1)
//The register 0x23 contains CS/ALS Interrupt upper threshold 2 upper byte data (ALS_THRES_UP_2)

//The register 0x24 contains CS/ALS Interrupt lower threshold lower byte data (ALS_THRES_LOW_0)
//The register 0x25 contains CS/ALS Interrupt lower threshold 1 upper byte data (ALS_THRES_LOW_1)
//The register 0x26 contains CS/ALS Interrupt lower threshold 2 upper byte data (ALS_THRES_LOW_2)

```
// To set ALS Upper threshold for Interrupt
Upper_Threshold_Value=1000           // Example 1000
Data2 = Upper_Threshold_Value >> 16 // Shift right to extract the 2 upper byte
Data1 = Upper_Threshold_Value >> 8  // Shift right to extract the 1 upper byte
Data0 = Upper_Threshold_Value & 0xFF // Mask to extract lower byte.
```

```
Register_Addr = 0x21           // ALS_THRES_UP_0 Register address
WriteByte(Slave_Addr, Register_Addr, Data0)
Register_Addr = 0x22           // ALS_THRES_UP_1 Register address
WriteByte(Slave_Addr, Register_Addr, Data1)
Register_Addr = 0x23           // ALS_THRES_UP_2 Register address
WriteByte(Slave_Addr, Register_Addr, Data2)
```

```
// To set ALS Lower threshold for Interrupt
Lower_Threshold_Value=100       // Example 100
Data2 = Lower_Threshold_Value >> 16 // Shift right to extract the 2 upper byte
Data1 = Lower_Threshold_Value >> 8  // Shift right to extract the 1 upper byte
Data0 = Lower_Threshold_Value & 0xFF // Mask to extract lower byte.
```

```
Register_Addr = 0x24           // CS/ALS_THRES_LOW_0 Register address
WriteByte(Slave_Addr, Register_Addr, Data0)
Register_Addr = 0x25           // CS/ALS_THRES_LOW_1 Register address
WriteByte(Slave_Addr, Register_Addr, Data1)
Register_Addr = 0x26           // CS/ALS_THRES_LOW_2 Register address
WriteByte(Slave_Addr, Register_Addr, Data2)
```

OPTICAL SENSOR LTR-381RGB-WA

9 Recommended Leadfree Reflow Profile

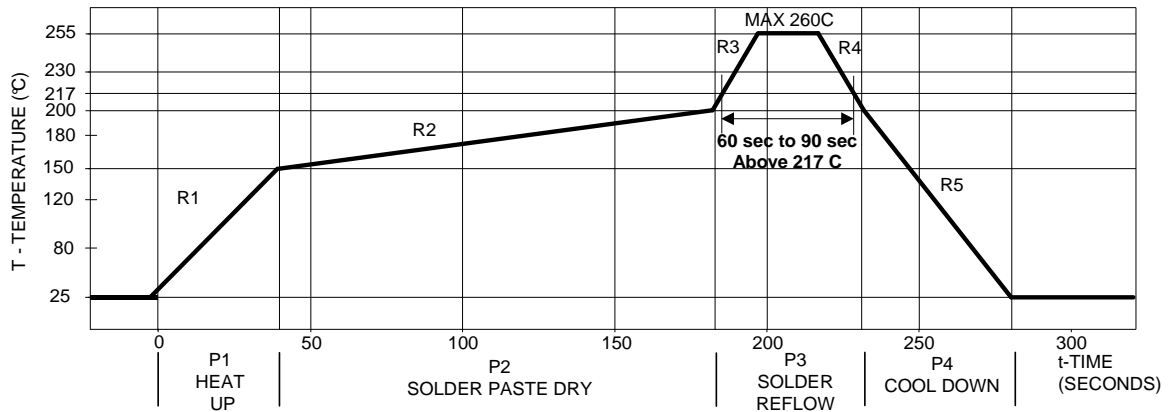

Process Zone	Symbol	ΔT	Maximum $\Delta T/\Delta t$ or Duration
Heat Up	P1, R1	25°C to 150°C	3°C/s
Solder Paste Dry	P2, R2	150°C to 200°C	100s to 180s
Solder Reflow	P3, R3	200°C to 260°C	3°C/s
	P3, R4	260°C to 200°C	-6°C/s
Cool Down	P4, R5	200°C to 25°C	-6°C/s
Time maintained above liquid's point , 217°C		> 217°C	60s to 90s
Peak Temperature		260°C	-
Time within 5°C of actual Peak Temperature		> 255°C	20s
Time 25°C to Peak Temperature		25°C to 260°C	8mins

It is recommended to perform reflow soldering no more than twice.

OPTICAL SENSOR LTR-381RGB-WA

10 Moisture Proof Packaging

All LTR-381RGB-WA are shipped in moisture proof package. Once opened, moisture absorption begins. This part is compliant to JEDEC J-STD-033A Level 3.

Time from Unsealing to Soldering

After removal from the moisture barrier bag, the parts should be stored at the recommended storage conditions and soldered within seven days. When the moisture barrier bag is opened and the parts are exposed to the recommended storage conditions for more than seven days, the parts must be baked before reflow to prevent damage to the parts.

Recommended Storage Conditions

Storage Temperature	10°C to 30°C
Relative Humidity	Below 60% RH

Baking Conditions

Package	Temperature	Time
In Reels	60°C	48 hours
In Bulk	100°C	4 hours

Baking should only be done once.

OPTICAL SENSOR LTR-381RGB-WA

11 Recommended Land Pattern

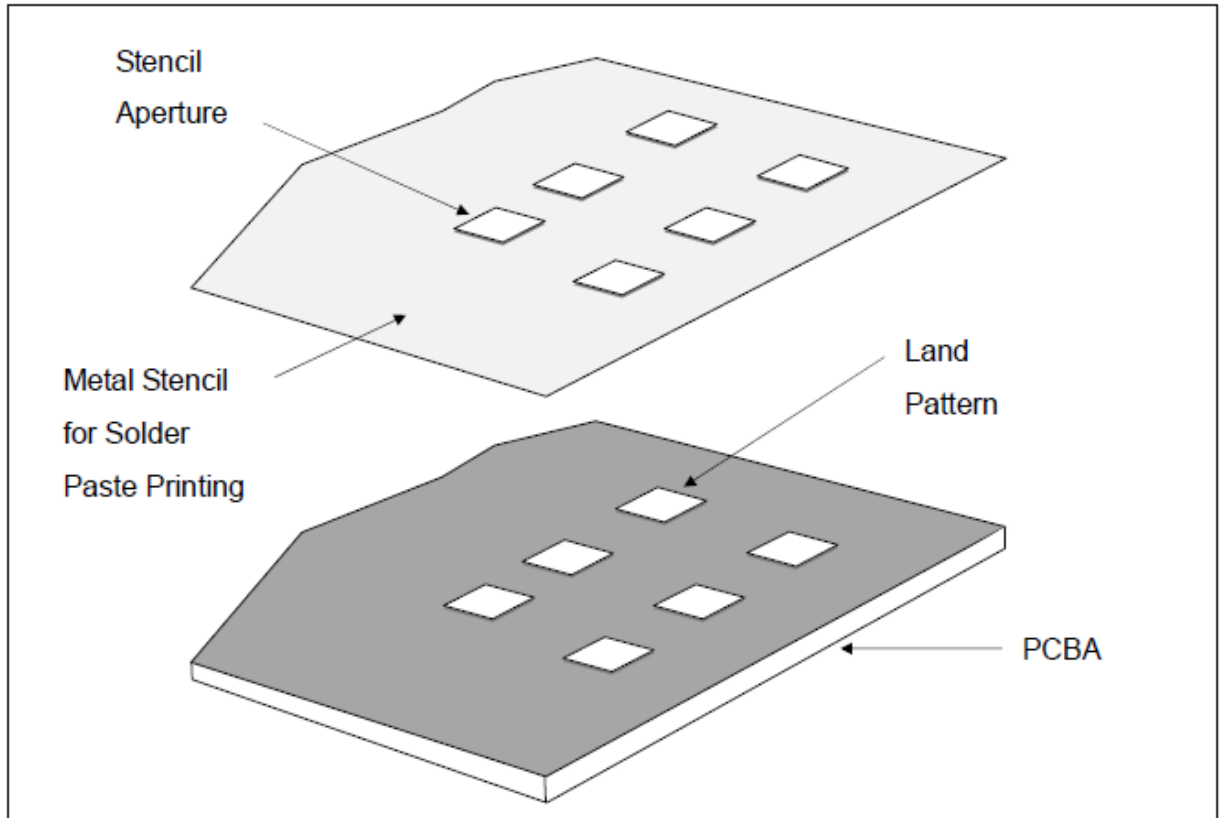

Recommended Land Pattern for LTR-381RGB-WA

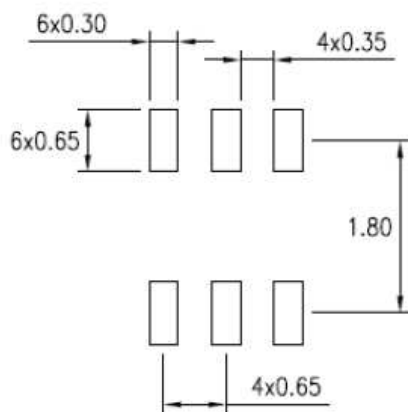

Note: All dimensions are in millimeters

OPTICAL SENSOR LTR-381RGB-WA

12 Metal Stencil Aperture

It is recommended that the metal stencil used for solder paste printing has a thickness (t) of 0.11mm (0.004 inches / 4 mils) or 0.127mm (0.005 inches / 5 mils).

The stencil aperture opening is recommended to be 0.3mm x 0.65mm which has the same dimension as the land pattern. This is to ensure adequate printed solder paste volume and yet no shorting.

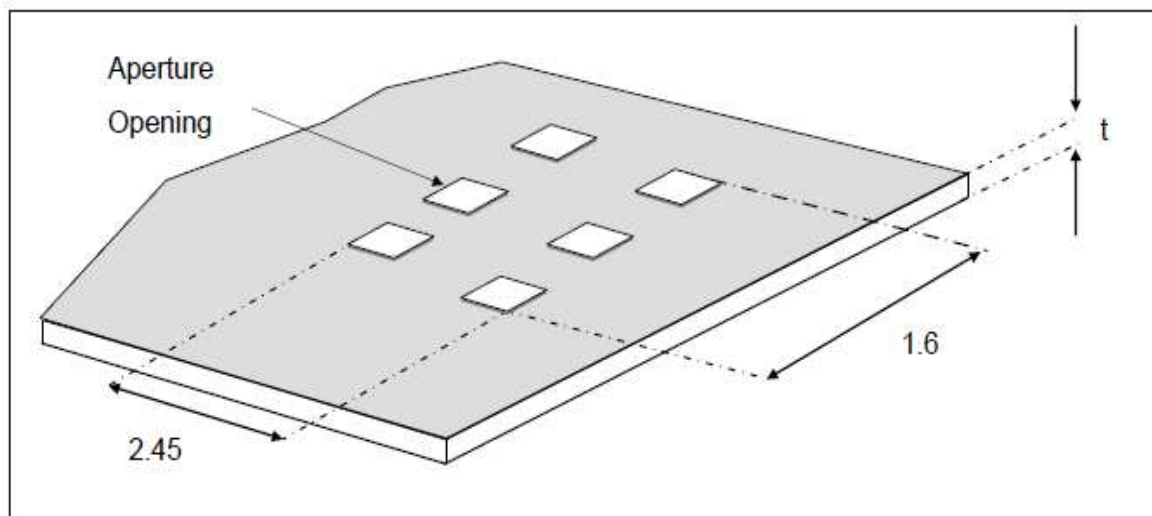

Note:

1. All dimensions are in millimeters

OPTICAL SENSOR LTR-381RGB-WA

13 Tape and Reel Dimensions

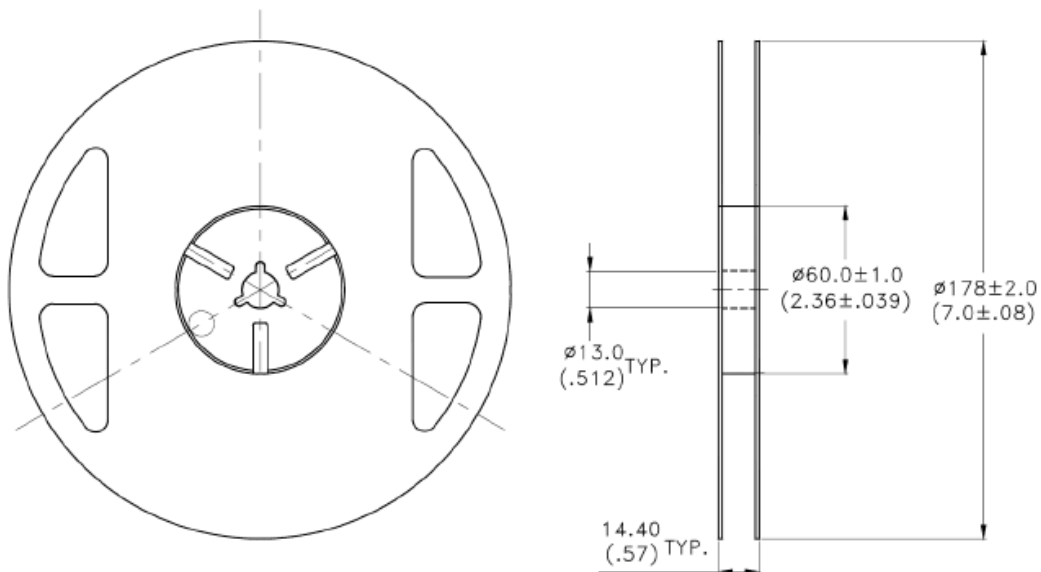
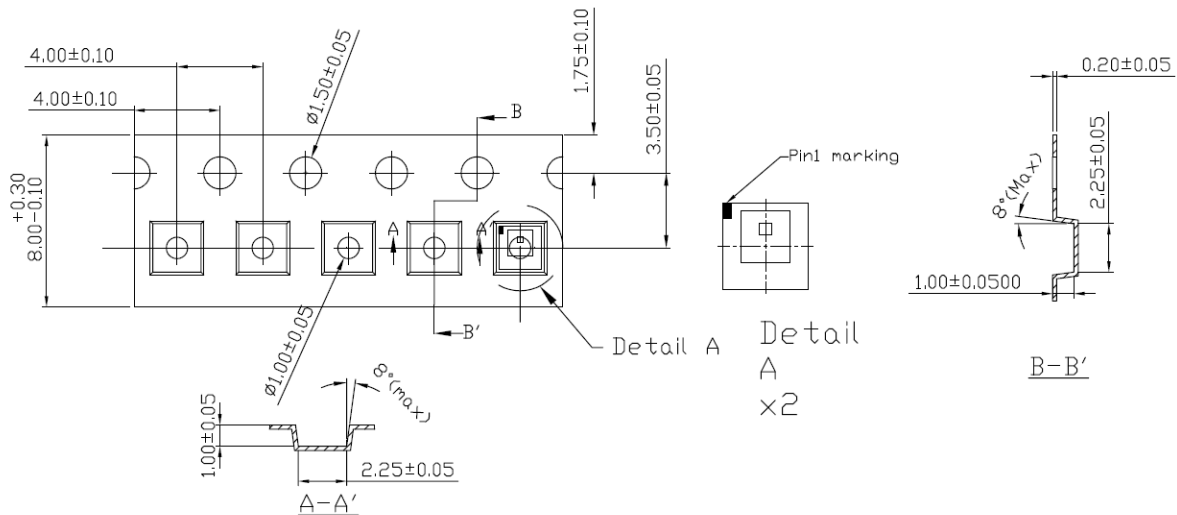

Notes:

1. All dimensions are in millimeters (inches)
2. Empty component pockets sealed with top cover tape
3. 7 inch reel - 2500 pieces per reel
4. In accordance with ANSI/EIA 481-1-A-1994 specifications

**OPTICAL SENSOR
LTR-381RGB-WA**

Revision Table:

Version	Update	Page	Date
1.0	Datasheet as created	Total 34	04-Jul-17
1.1	Update datasheet (Remove extra info and update integration time)	5,6	6-Jul-17
1.2	Update VHBM info	5	7-Jul-17