

## DESCRIPTION

The PT2467 provides an integrated motor driver for cameras, consumer products, toys and other application with low-voltage or battery-powered motion control.

The PT2467 can supply up to 1A of output DC current. It operates on a motor power supply (VM) from 0 to 12V and a device power supply voltage (VCC) of 1.8V to 6V.

The PT2467 has a PWM (IN1-IN2) input interface Full protections are integrated with over-current protection, under-voltage lockout and over-temperature shutdown.

## FEATURE

- H-Bridge Motor Driver
  - DC Motor or Other Loads
  - Low On-Resistance : HS+LS 1Ω
- 1-A Maximum DC Drive Current
- Separate Motor and Logic Supply
  - Motor VM : 0 to 12V
  - Logic VCC : 1.8V to 6V
- Low-Power Sleep Mode
  - 10nA with IVM and IVCC
- Small Package and Footprint
  - 8-Pin DFN with Thermal PAD(2.0 X 2.0 mm)
  - 8-Pin SOP
- Protection Features
  - VCC Under-Voltage Lockout
  - Over-Current Protection
  - Thermal Shutdown

## APPLICATION

- Cameras
- DSLR Lenses
- Consumer Products
- Toys
- Robotics

## BLOCK DIAGRAM

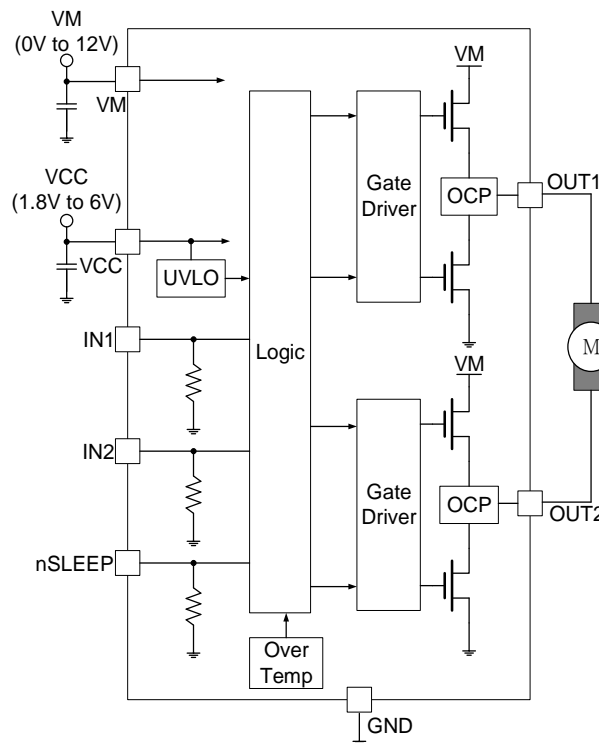

**Figure 1. Function Block Diagram**

# APPLICATION CIRCUIT

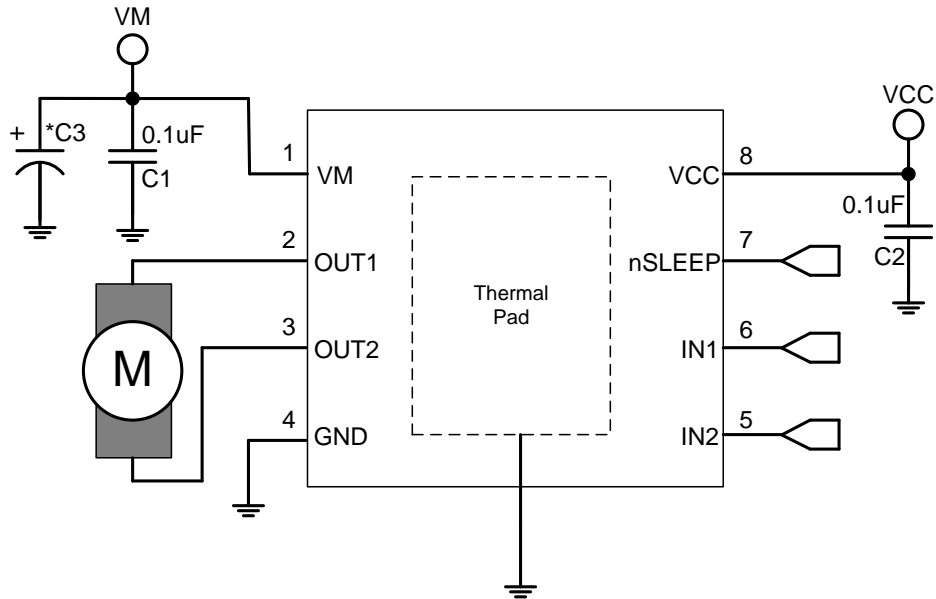

Figure 2. Schematic of Application

The recommended  $C_3$  is 10 $\mu\text{F}$  above. Details are referred to at the chapter "Power Supply Recommendations".

## ORDER INFORMATION

Valid Part Number	Package Type	Top Code
PT2467-S	SOP 8	PT2467-S
PT2467	DFN 8	PT2467

## PIN DESCRIPTION

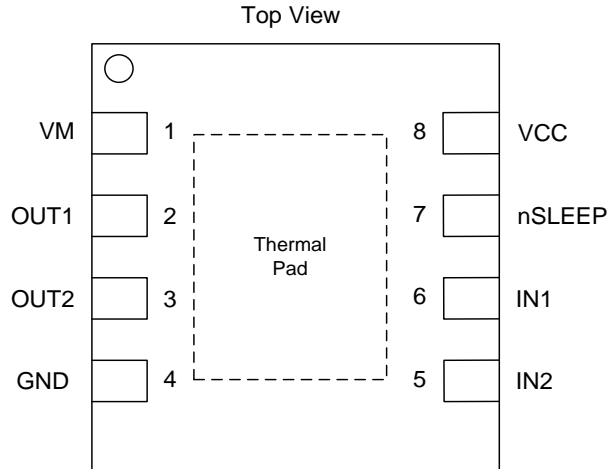

Pin Name	I/O	Description	Pin No.
VM	Power	Motor power supply	1
OUT1	Output	Motor output 1	2
OUT2	Output	Motor output 2	3
GND	Power	Ground	4
IN2	Input	Input 2	5
IN1	Input	Input 1	6
nSLEEP	Input	Sleep mode input	7
VCC	Power	Logic power supply	8

# FUNCTION DESCRIPTION

## BRIDGE CONTROL

The PT2467 is controlled using a PWM input interface, also called an IN-IN interface. Each output is controlled by a corresponding input pin.

nsleep	IN1	IN2	Out1	Out2	Function (DC Motor)
0	X	X	Z	Z	Coast
1	0	0	Z	Z	Coast
1	0	1	L	H	Reverse
1	1	0	H	L	Forward
1	1	1	L	L	Brake

**Table 1. Control Logic**

## PROTECTION MANAGEMENT

The PT2467 is fully protected against VCC under-voltage, overcurrent, and over-temperature events

Fault	Condition	H-Bridge	Recovery
VCC Under-Voltage	VCC < 1.6V	Disable	VCC>1.8V
Over-Current	IOUT > 1.9A (MIN)	Disable	tRETRY
Thermal Shutdown	TJ > 150°C (MIN)	Disable	TJ < 150°C

**Table 2. Fault Behavior**

## FUNCTIONAL MODES

The PT2467 is active unless the nSLEEP pin is brought logic low. In sleep mode, the H-bridge FETs are disabled Hi-Z. The PT2467 is brought out of sleep mode automatically if nSLEEP is brought logic high.

Mode	Condition	H-Bridge
Operating	nSLEEP pin=1	Operating
Sleep Mode	nSLEEP pin=0	Disabled
Fault Encountered	Any fault condition met	Disabled

**Table 3. Operation Modes**

## POWER SUPPLY RECOMMENDATIONS

Having appropriate local bulk capacitance is an important factor in motor-drive system design. It is generally beneficial to have more bulk capacitance.

The amount of local bulk capacitor needed depends on the following factors,

- The highest current required by the motor system.
- The power-supply capacitance and ability to source current
- The amount of parasitic inductance between the power supply and motor system
- The acceptable voltage ripple
- The type of motor used (brushed dc, brushless dc, stepper)
- The motor braking method.

The inductance between the power supply and motor drive system limits the rate at which current can change from the power supply. If the local bulk capacitance is too small, the system responds to excessive current demands or dumps from the motor with a change in voltage. When adequate bulk capacitance is used, the motor voltage remains stable and high current can be quickly supplied.

The voltage rating for bulk capacitors should be higher than the operating voltage, to provide margin for cases when the motor transfers energy to supply. The recommended C3 is 10uF above.

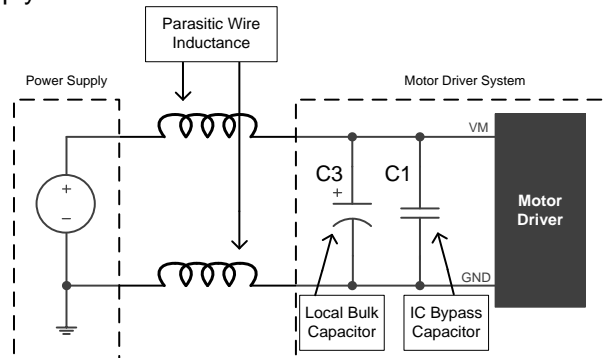

Figure 3. Motor Driver System with External Power Supply

## PCB LAYOUT

The VM and VCC should be bypassed to GND using low-ESR ceramic capacitors with recommended value of 0.1uF. These capacitors should be placed as close to the VM and VCC as possible with a thick trace or ground plane connection to GND.

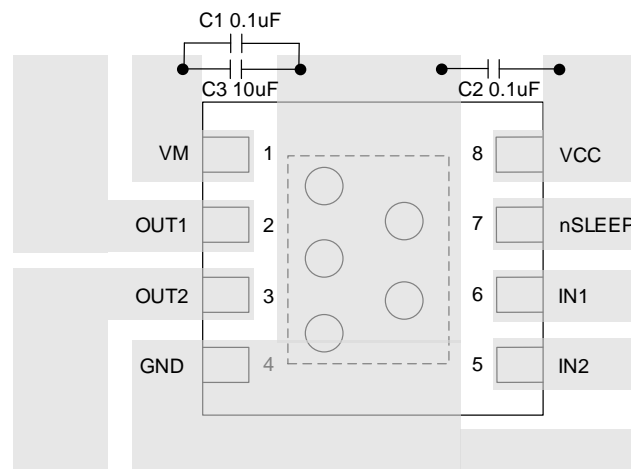

Figure 4. Simplified Layout Example

## ABSOLUTE MAXIMUM RATINGS

Parameters		Min	Max	Unit
Motor Power Supply Voltage , VM		-0.3	13	V
Logic Power Supply Voltage , VCC		-0.3	6.5	V
Operating Temperature, Top		-40	150	°C
Storage Temperature, Tstg		-40	150	°C
Operation Humidity		20	85	%
Storage Humidity		20	90	%
ESD	All Pins	HBM	±4	KV
		MM	±0.4	KV
		CDM*	±1.5	KV

\*CDM test is based on ANSI/ESDA/JEDEC JS-002-2014

## RECOMMENDED OPERATING CONDITIONS

Parameters		Min	Max	Unit
VM	Motor Power Supply Voltage	0	12	V
VCC	Logic Power Supply Voltage	1.8	6	V
I <sub>OUT</sub>	Motor Peak Current	0	1	A
f <sub>PWM</sub>	Externally Applied PWM Frequency	0	250	KHz
V <sub>LOGIC</sub>	Logic Level Input Voltage	0	6	V
T <sub>A</sub>	Operating Ambient Temperature	-40	85	°C

## PACKAGE THERMAL CHARACTERISTICS

### PACKAGE: DFN

Parameter	Symbol	Value	Unit
From chip conjunction dissipation to external environment	$\theta_{JA}$	75.6	°C/W

### PACKAGE: SOP, 150MIL

Parameter	Symbol	Value	Unit
From chip conjunction dissipation to external environment	$\theta_{JA}$	113.9	°C/W



# ELECTRICAL CHARACTERISTICS

TA=25°C , over recommended operating conditions unless otherwise noted

Symbol	Parameter	Test Conditions	Min	Typ	Max	Unit
<b>POWER SUPPLIES(VM, VCC)</b>						
VM Current						
I <sub>VM1</sub>	VM coast current	VM=5V ; VCC=3V ; No PWM Coast Mode		70		μA
I <sub>VM2</sub>	VM F/R current	VM=5V ; VCC=3V ; No PWM Forward/Reverse Mode		350		μA
I <sub>VM3</sub>	VM brake current	VM=5V ; VCC=3V ; No PWM Brake Mode		70		μA
I <sub>VM4</sub>	VM PWM current	VM=5V ; VCC=3V PWM=50KHz		280		μA
I <sub>VMQ</sub>	VM sleep current	VM=5V ; VCC=3V nSLEEP=0		5		nA
VCC Current						
I <sub>VCC1</sub>	VCC coast current	VM=5V ; VCC=3V ; No PWM Coast Mode		380		μA
I <sub>VCC2</sub>	VCC F/R current	VM=5V ; VCC=3V ; No PWM Forward/Reverse Mode		500		μA
I <sub>VCC3</sub>	VCC brake current	VM=5V ; VCC=3V ; No PWM Brake Mode		550		μA
I <sub>VCC4</sub>	VCC PWM current	VM=5V ; VCC=3V PWM=50KHz		450		μA
I <sub>VCCQ</sub>	VCC sleep current	VM=5V ; VCC=3V nSLEEP=0		2		nA
<b>CONTROL INPUTS (IN1, IN2, nSLEEP)</b>						
V <sub>IL</sub>	Input logic low voltage				0.3*VCC	V
V <sub>IH</sub>	Input logic high voltage		0.5*VCC			V
I <sub>IL</sub>	Input logic low current	VIN=0V			5	μA
I <sub>IH</sub>	Input logic high current	VIN=3.3V			50	μA
R <sub>PD</sub>	Pulldown resistance	IN1 IN2 nSLEEP		100		KΩ
<b>MOTOR DRIVER OUTPUTS (OUT1, OUT2)</b>						
r <sub>DS(ON)</sub>	HS + LS FETs on-resistance	VM=5V ; VCC=3V ; I <sub>o</sub> =800mA		700		mΩ
I <sub>OFF</sub>	Off-state leakage current	VO <sub>UT</sub> =0V		5		nA
<b>PROTECTION CIRCUITS</b>						
V <sub>UVLO</sub>	VCC under-voltage lockout	VCC falling		1.6		V
		VCC rising		1.8		V
I <sub>OC</sub>	Over-current protection trip level		1.2		2	A
t <sub>RETRY</sub>	Over-current retry time			1		mS
T <sub>TSD</sub>	Thermal shutdown temperature	Die temperature		160		°C

# TIMING REQUIREMENTS

TA=25°C, VM=5V, VCC=3V, RL=20Ω

Time	Parameter	Max	Unit
t1	Output enable time	700	nS
t2	Output disable time	700	nS
t3	Delay time, INx high to OUTx high	380	nS
t4	Delay time, INx low to OUTx low	380	nS
t5	Output rise time	280	nS
t6	Output fall time	280	nS
twake	Wake time , nSLEEP rising edge to part active	10	μS

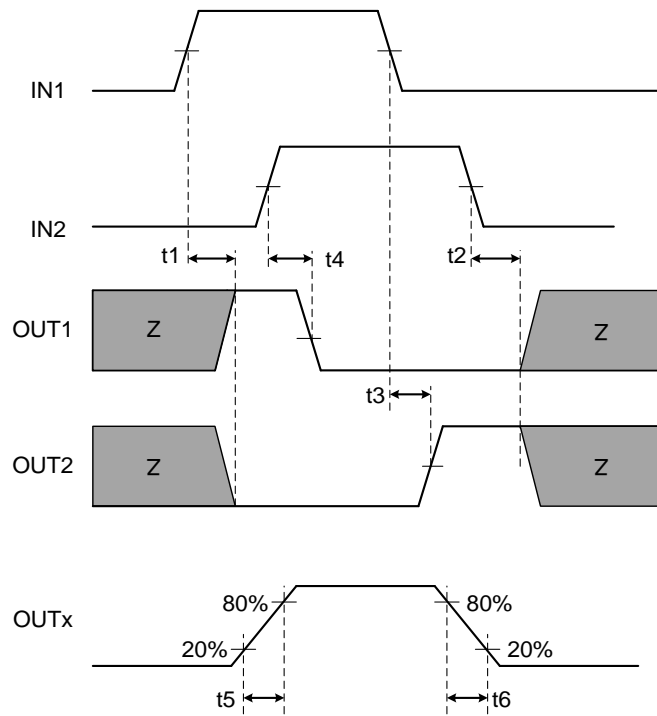
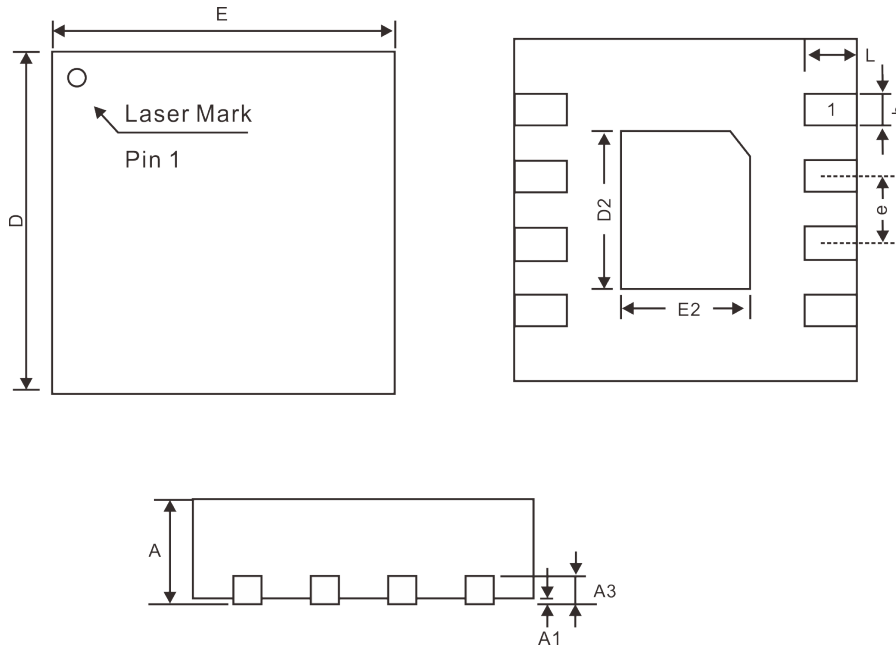

Figure 5. Input and Output Timing



# PACKAGE INFORMATION

## 8-PIN, DFN



Symbol	Dimensions(mm)		
	Min.	Nom.	Max.
A	0.70	0.75	0.80
A1	0.00	0.02	0.05
A3	0.20 REF		
b	0.18	0.25	0.30
D	2.00 BSC		
E	2.00 BSC		
e	0.50 BSC		
D2	1.50	1.60	1.65
E2	0.80	0.90	0.95
L	0.25	0.30	0.35

Note: Refer to JEDEC MO-229

**8 PINS, SOP, 150MIL**

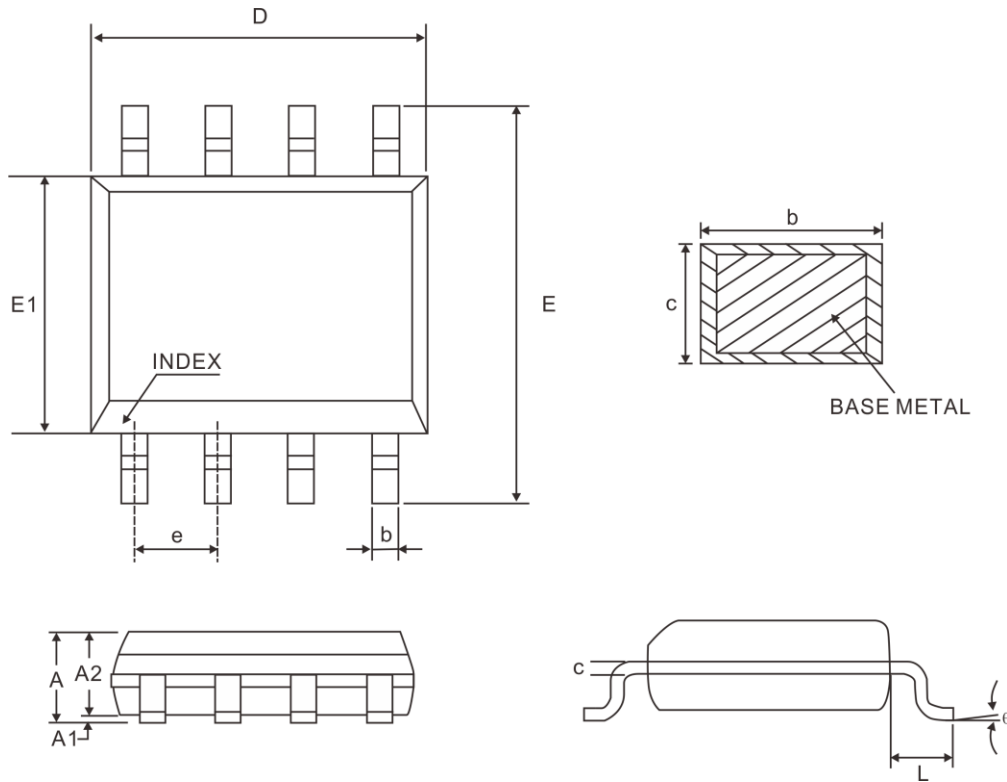

Symbol	Dimensions(mm)		
	Min.	Nom.	Max.
A	-	-	1.75
A1	0.10	-	0.25
A2	1.25	-	-
b	0.31	-	0.51
c	0.10	-	0.25
D	4.90 BSC		
E	6.00 BSC		
E1	3.90 BSC		
e	1.27BSC		
L	0.40	-	1.27
$\theta$	0°	-	8°

- Notes:
1. Refer to JEDEC MS-012 AA
  2. All dimensions are in millimeter

## **IMPORTANT NOTICE**

Princeton Technology Corporation (PTC) reserves the right to make corrections, modifications, enhancements, improvements, and other changes to its products and to discontinue any product without notice at any time.

PTC cannot assume responsibility for use of any circuitry other than circuitry entirely embodied in a PTC product. No circuit patent licenses are implied.

Princeton Technology Corp.  
2F, 233-1, Baociao Road,  
Sindian Dist, New Taipei City 23145, Taiwan  
Tel: 886-2-66296288  
Fax: 886-2-29174598  
<http://www.princeton.com.tw>