



LC3030

High Efficiency Low Noise PFM Step-up DC/DC Converter

DESCRIPTION

LC3030 series are CMOS-based PFM step-up DC-DC Converter. The converter can start up by supply voltage as low as 0.8V, and capable of delivering maximum 200mA output current at 3.3V output with 1.8V input Voltage. Quiescent current drawn from power source is as low as 5.5uA. All of these features make LC3030 series be suitable for the portable devices, which are supplied by a single battery to four-cell batteries.

To reduce the noise caused by the switch regulator, LC3030 is well considerate in circuit design and manufacture, so that the interferer to other circuits by the device is reduced greatly.

LC3030 integrates stable reference circuits and trimming technology, so it can afford high precision and low temperature-drift coefficient of the output voltage.

LC3030 is available in SOT-23-3, TSOT-23-3, SOT-23-5, SOT-89-3 and TO-92 packages, which are PB free. And in 5-pin packages, such as SOT-23-5, the device can be switch on or off easily by CE pin, to minimize the standby supply current.

TYPICAL APPLICATION

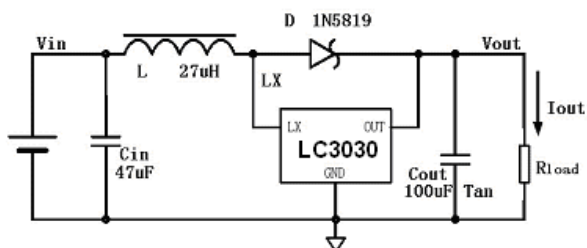

FEATURES

- Deliver 200mA at 3.3V output voltage with 1.8V input voltage
- Low start-up voltage (when the output current is 1mA)-----0.8V
- Output voltage can be adjusted from 2.5V~6.0V (In 0.1V step)
- Output voltage accuracy ----- $\pm 2\%$
- Low temperature-drift coefficient of the output voltage----- $\pm 100\text{ppm}/^\circ\text{C}$
- Only three external components are necessary: an inductor, a Schottky diode and an output filter capacitor
- High power conversion efficiency-----85%
- Low quiescent current drawn from power source----- $< 5.5\mu\text{A}$

APPLICATIONS

- Power Source for PDA, DSC, MP3 Player, Electronic toy and wireless mouse
- Power Source for a Single or Dual-cell Battery-Powered Equipments
- Power Source for LED

ELECTRICAL CHARACTERISTICS

LC3030CC3TR33 Output Voltage VS. Output Current

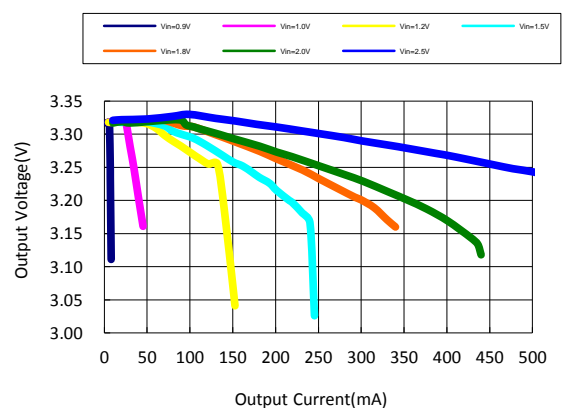

ORDERING INFORMATION

LC3030   

Code	Description
1	Temperature&Rohs: C: -40~85°C, Pb Free Rohs Std.
2	Package type: B3: SOT-23-3 B3A: TSOT-23-3 B5: SOT-23-5 C3: SOT-89-3 H: TO-92
3	Packing type: TR: Tape&Reel (Standard) BG: Bag (TO-92)
4	Output voltage: e.g. 25=2.5V 33=3.3V 60=6.0V

ABSOLUTE MAXIMUM RATING

Parameter	Value	
Input voltage range	-0.3V-12V	
Input voltage	-0.3V-(Vout+0.3)	
CE pin voltage	-0.3V-(Vout+0.3)	
Lx pin output current	0.7A	
Operating junction temperature (T _j)	125°C	
Ambient temperature (T _A)	-40°C -85°C	
Power dissipation	SOT-23-3	250mW
	TSOT-23-3	250mW
	SOT-23-5	250mW
	SOT-89-3	500mW
	TO-92	500mW
Storage temperature (T _S)	-40°C -150°C	
Lead temperature & time	260°C, 10S	



Note:

Exceed these limits to damage to the device.
Exposure to absolute maximum rating conditions may affect device reliability.

PIN CONFIGURATION

CE	Chip enable (active high)
GND	Ground
OUT	Output feedback pin, power supply for internal
Lx	Switching pin
NC	No connection

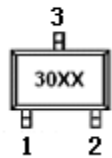
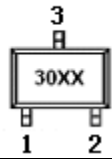
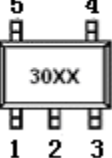
MARKING INFORMATION

Product classification		LC3030CB3TR□□
Marking		SOT-23-3
30XX	30:product code	
	XX: output voltage	
Product classification		LC3030CB3ATR□□
Marking		TSOT-23-3
30XX	30:product code	
	XX: output voltage	
Product classification		LC3030CB5TR□□
Marking		SOT-23-5
30XX	30:product code	
	XX: output voltage	
Product classification		LC3030CC3TR□□
Marking		SOT-89-3
LAXX YYBZZ	LA: product code	
	XX: output voltage	
	YY: LOT NO.	
	B: FAB code	
	ZZ: date code	
Product classification		LC3030CHBG□□
Marking		TO-92
LAXX YYBZZ	LA: product code	
	XX: output voltage	
	YY: LOT NO.	
	B: FAB code	
	ZZ: date code	

RECOMMENDED WORK CONDITIONS

Item	Min	Recommended	Max.	Unit
Input voltage range	0.8		V_{OUT}	V
Inductor	10	27	100	μ H
Input capacitor	0	≥ 10		μ F
Output capacitor	47	100	220	μ F
Ambient temperature	-40		85	$^{\circ}$ C

ELECTRICAL CHARACTERISTICS

Symbol	Parameter	Conditions	Min	Typ	Max	Unit
V_{OUT}	Output voltage		2.45	2.5	2.55	V
			2.646	2.7	2.754	
			2.94	3.0	3.06	
			3.234	3.3	3.366	
			3.528	3.6	3.672	
			3.92	4.0	4.08	
			4.9	5.0	5.1	
			5.88	6.0	6.12	
V_{IN}	Input voltage				7	V
I_{IN}	Input current	$I_{OUT}=0mA, V_{IN}=V_{OUT}*0.6$		12	15	μ A
V_{START}	Start-up voltage	$I_{OUT}=1mA, V_{IN}: 0 \rightarrow 2V$		0.8	0.9	V
V_{HOLD}	Hold-on voltage	$I_{OUT}=1mA, V_{IN}: 2 \rightarrow 0V$	0.6	0.7		V
I_{DD}	Quiescent current drawn from power source	Without external components, $V_{OUT}=V_{OUT}*1.05$		4	7	μ A
R_{SWON}	Switch ON resistance			0.4	0.5	Ω
I_{LXLEAK}	LX leakage current	$V_{OUT}=V_{LX}=6V$		0.5	5	μ A
V_{CEH}	CE "H" threshold voltage	$V_{CE}: 0 \rightarrow 2V$	0.8			V
V_{CEL}	CE "H" threshold voltage	$V_{CE}: 2 \rightarrow 0V$			0.3	V
F_{OSC}	Oscillator frequency	LX on "L" side, $V_{OUT}=V_{OUT}*0.96$		350		KHz
MAX_{DTY}	Oscillator duty cycle	On(V_{LX} "L")side	70	75	80	%
η	Efficiency			85		%

Note:

1. Diode: Schottky type, such as: 1N5817, 1N5819, 1N5822
2. Inductor: 27 μ H($R < 0.5\Omega$)
3. Capacitor: 00 μ F(Tantalum type)

BLOCK DIAGRAM

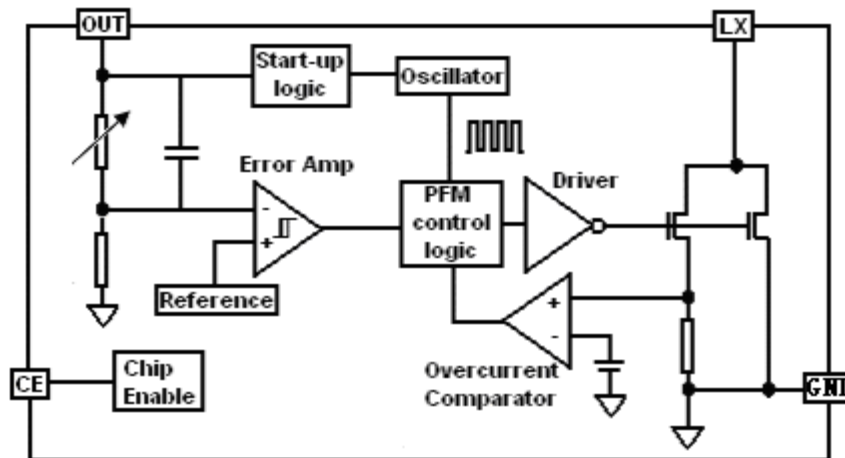

Note: CE pin is only available on 5 pins packages.

DETAILED DESCRIPTION

The LC3030 series are boost structure, voltage-type Pulse-Frequency Modulation (PFM) step-up DC-DC converter. Only three external components are necessary: an inductor, an output filter capacitor and a schottky diode. And the converter's low noise and low ripple output voltage can be adjusted from 2.5V to 5.0V, 0.1V step. By using the depletion technics, the quiescent current drawn from power source is lower than 7uA. The high efficiency device consists of resistors for output voltage detection and trimming, a start-up voltage circuit, an oscillator, a reference circuit, a PFM control circuit, a switch protection circuit and a driver transistor.

The PFM control circuit is the core of the LC3030 IC. This block controls power switch on duty cycle to stabilize output voltage by calculating results of other blocks which sense input voltage, output voltage, output current and load conditions. In PFM modulation system, the frequency and pulse width is fixed. The duty cycle is adjusted by skipping pulses, so that switch on-time is changed based on the conditions such as input voltage, output current and load. The oscillate block

inside LC3030 provides fixed frequency and pulse width wave.

The reference circuit provides stable reference voltage to output stable output voltage. Because internal trimming technology is used, the chip output change less than $\pm 2\%$. At the same time, the problem of temperature-drift coefficient of output voltage is considered in design, so temperature-drift coefficient of output voltage is less than 100ppm/ $^{\circ}\text{C}$.

High-gain differential error amplifier guarantees stable output voltage at difference input voltage and load. In order to reduce ripple and noise, the error amplifier is designed with high band-with.

Though at very low load condition, the quiescent current of chip do affect efficiency certainly. The four main energy loss of Boost structure DC-DC converter in full load are the ESR of inductor, the voltage of Schottky diode, on resistor of internal N-channel MOSFET and its driver. In order to improve the efficiency, LC3030 integrates low on-resistor N-channel MOSFET and well design driver circuits. The switch energy loss is limited at very low level.

SELECTION THE EXTERNAL COMPONENTS

Thus it can be seen, the inductor and schottky diode affect the conversion efficiency greatly. The inductor and the capacitor also have great influence on the output voltage ripple of the converter. So it is necessary to choose a suitable inductor, a capacitor and a right schottky diode, to obtain high efficiency, low ripple and low noise. Before discussion, we define

$$D \equiv \frac{V_{out} - V_{in}}{V_{out}}$$

Inductor selection

Above all, we should define the minimum value of the inductor that can ensure the boost DC-DC to operate in the continuous current-mode condition.

$$L_{min} \geq \frac{D(1-D)^2 R_L}{2f}$$

The above expression is got under conditions of continuous current mode, neglect Schottky diode's voltage, ESR of both inductor and capacitor. The actual value is greater than it. If inductor's value is less than L_{MIN} , the efficiency of DC-DC converter will drop greatly, and the DC-DC circuit will not be stable.

Secondly, consider the ripple of the output voltage,

$$\Delta I = \frac{D \cdot V_{in}}{L f}$$

$$I_{max} = \frac{V_{in}}{(1-D)^2 R_L} + \frac{D V_{in}}{2L f}$$

If inductor value is too small, the current ripple through it will be great. Then the current through diode and power switch will be great. Because the power switch on chip is not ideal switch, the energy of switch will improve. The efficiency will fall.

Thirdly, in general, smaller inductor values supply more output current while larger values start up with lower input voltage and acquire high efficiency.

An inductor value of 3uH to 1mH works well in most applications. If DC-DC converter delivers large output current (for example: output current is great than 50mA), large inductor value is recommended in order to improve efficiency. If DC-DC must output very large current at low input supply voltage, small inductor value is recommended.

The ESR of inductor will affect efficiency greatly. Suppose ESR value of inductor is r_L , R_{load} is load resistor, then the energy can be calculated by following expression:

$$\Delta \eta \approx \frac{r_L}{R_{load}(1-D)^2}$$

For example: input voltage 1.5V, output voltage is 3.0V, $R_{LOAD}=20\Omega$, $r_L=0.5\Omega$, the energy loss is 10%.

Consider all above, inductor value of 47uH、ESR<0.5Ω is recommended in most applications. Large value is recommended in high efficiency applications and smaller value is recommended.

Capacitor selection

Ignore ESR of capacitor, the ripple of output voltage is:

$$r = \frac{\Delta V_{out}}{V_{out}} = \frac{D}{R_{load} C f}$$

So large value capacitor is needed to reduce ripple. But too large capacitor value will slow down system reaction and cost will improve. So 100uF capacitor is recommended. Larger capacitor value will be used in large output current system. If output current is small (<10mA), small value is needed.

Consider ESR of capacitor, ripple will increase:

$$r' = r + \frac{I_{max} \cdot R_{ESR}}{V_{out}}$$

When current is large, ripple caused by ESR will be main factor. It may be greater than 100mV. The ESR will affect efficiency and increase energy loss. So low-ESR capacitor (for example: tantalum capacitor) is recommend or connect two or more filter capacitors in parallel.

Diode selection

Rectifier diode will affect efficiency greatly, Though a common diode (such as 1N4148) will work well for light load, it will reduce about 5%~10% efficiency for heavy load, For optimum performance, a Schottky diode (such as 1N5817、1N5819、1N5822) is recommended.

Input capacitor

If supply voltage is stable, the DC-DC circuit can output low ripple, low noise and stable voltage without input capacitor. If voltage source is far away from DC-DC circuit, input capacitor value greater than 10uF is recommended.

TEST CIRCUITS

Output voltage test circuit
($I_{LOAD}=1mA$)

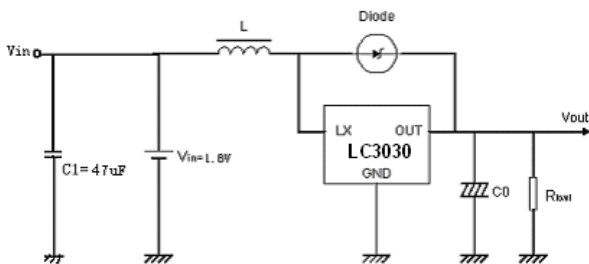

Quiescent current test circuit
($V_{OUT}=V_{OUT_NOM} * 1.05, R=1K\Omega, C=0.1uF$)

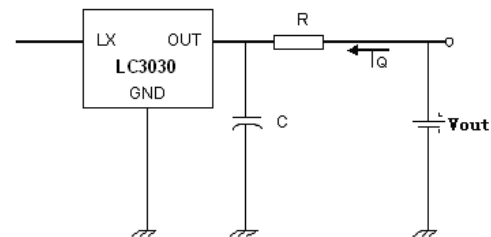

Start-up voltage test circuit
($I_{LOAD}=1mA$)

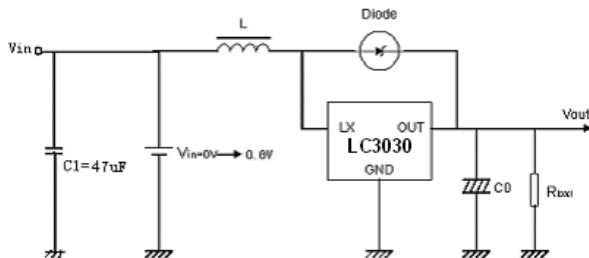

Oscillator frequency and duty cycle test circuit
($V_{IN}=V_{OUT} * 0.95, R=1K\Omega$)

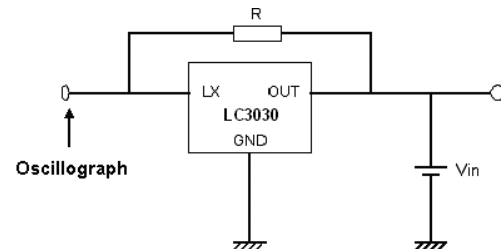

Hold-on voltage test circuit
($I_{LOAD}=1mA$)

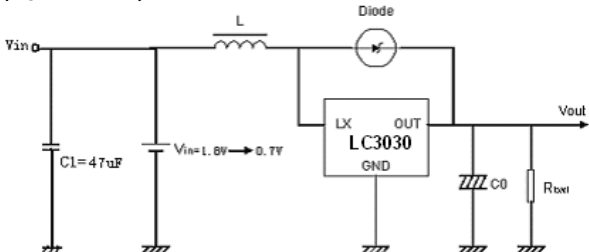

TYPICAL PERFORMANCE CHARACTERISTICS

Recommended operating conditions: $C_{IN}=47\mu F$, $C_{OUT}=47\mu F$, $T_{OPT}=25\text{ }^{\circ}\text{C}$. unless otherwise noted)

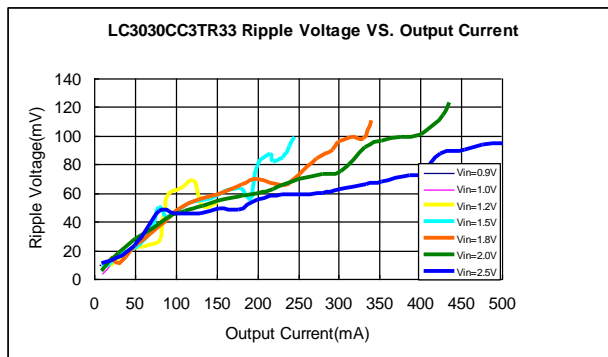
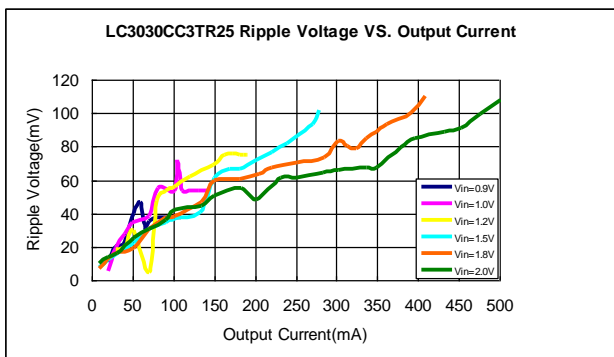
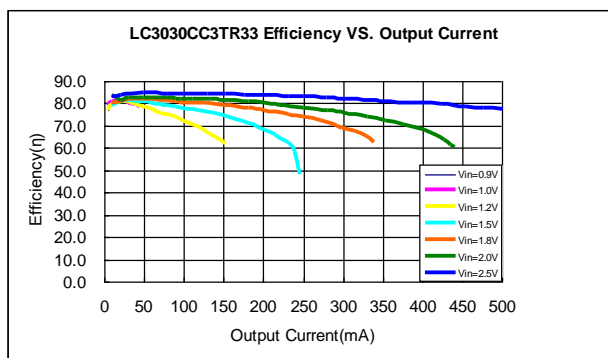
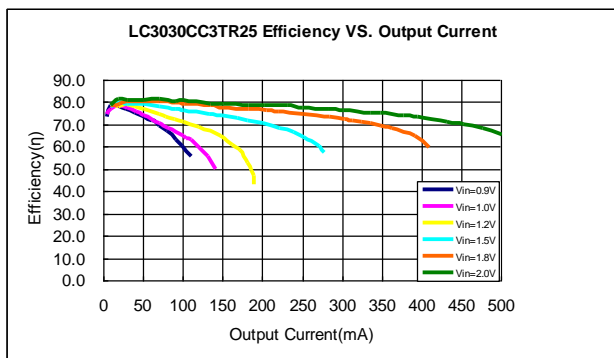
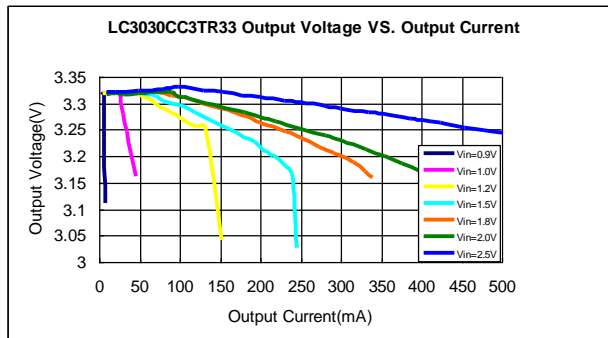
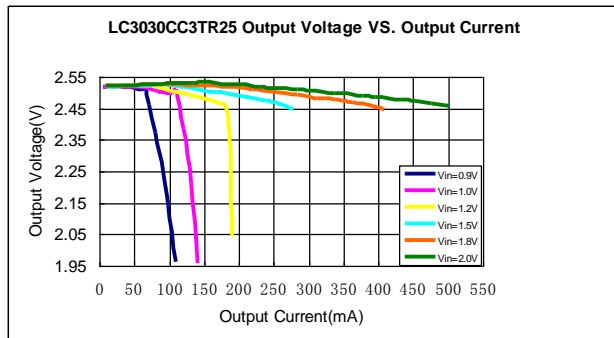

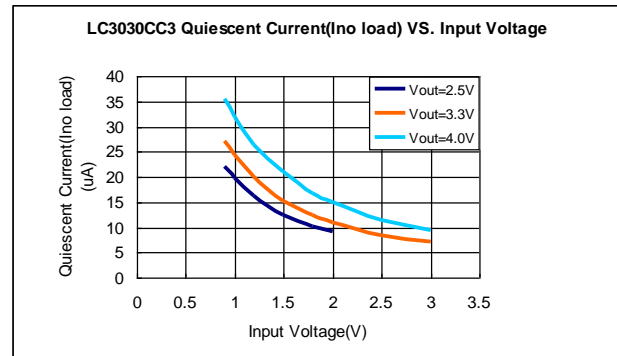
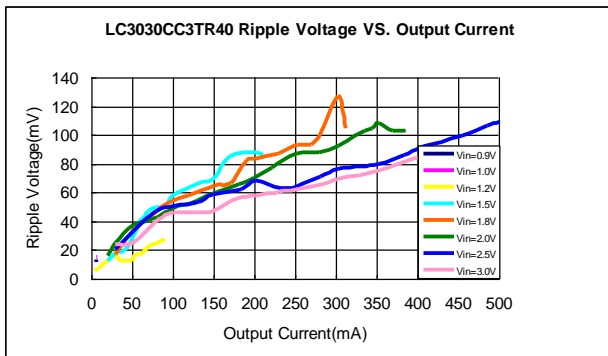
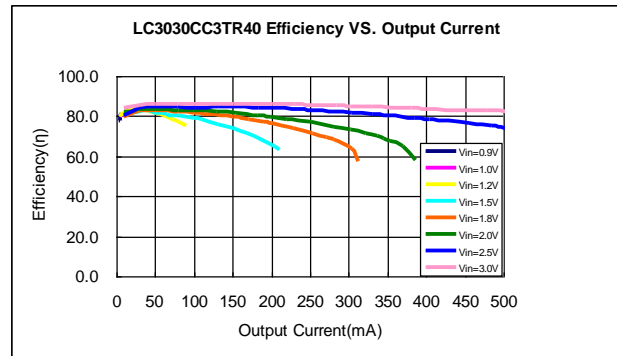
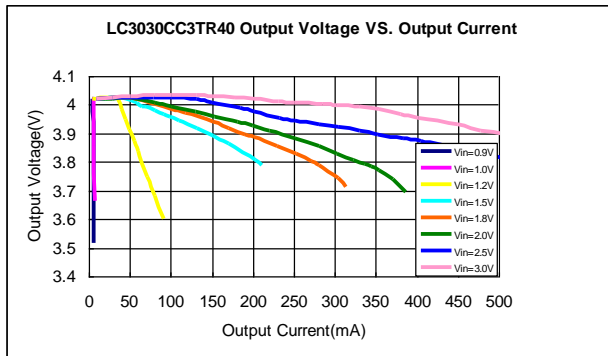

PACKAGE OUTLINE

Package	SOT-23-3	Devices per reel	3000pcs
Package dimension:			
<p>Technical drawing of the SOT-23-3 package. The top view shows a width of 2.9 ± 0.2 mm and a lead spacing of 1.9 ± 0.2 mm. The side view shows a height of 2.8 ± 0.3 mm and a lead height of 1.6 ± 0.2 mm. The cross-sectional view shows a lead width of 0.16 mm (tolerance $+0.1, -0.06$), a lead thickness of 0.2 mm (MIN.), and a lead angle of 0 to 0.1 degrees. Other dimensions include a lead length of 1.1 mm (tolerance $+0.2, -0.1$), a total lead length of 1.4 mm (MAX.), and a lead width of 0.8 mm. The top view also shows a lead width of 0.4 ± 0.1 mm and a lead height of 0.95 mm for each lead.</p>			
Unit: mm			

Package	TSOT-23-3	Devices per reel	3000pcs
Package dimension:			
<p>Technical drawing of the TSOT-23-3 package. The top view shows a width of 2.900 ± 0.05 mm and a lead spacing of 1.900 ± 0.05 mm. The side view shows a height of 2.400 ± 0.05 mm and a lead height of 1.300 ± 0.05 mm. The cross-sectional view shows a lead width of 0.100 mm (tolerance $+0.05, -0.01$), a lead thickness of 0.080 ± 0.02 mm, and a lead angle of $2 \times 7^\circ$. Other dimensions include a lead length of 0.400 ± 0.03 mm, a total lead length of 0.550 ± 0.05 mm, and a lead width of 0.400 ± 0.05 mm. The top view also shows a lead width of 0.400 ± 0.03 mm and a lead height of 0.550 ± 0.05 mm. The side view shows a lead width of 0.400 ± 0.05 mm and a lead height of 1.000 ± 0.05 mm. The cross-sectional view shows a lead width of 0.2 mm (MIN.), a lead thickness of 0.08 mm (R0.08), and a lead angle of $2 \times 7^\circ$. The top view also shows a lead width of 0.400 ± 0.03 mm and a lead height of 0.550 ± 0.05 mm. The side view shows a lead width of 0.400 ± 0.05 mm and a lead height of 1.000 ± 0.05 mm. The cross-sectional view shows a lead width of 0.2 mm (MIN.), a lead thickness of 0.08 mm (R0.08), and a lead angle of $2 \times 7^\circ$.</p>			
Unit: mm			

Package	SOT23-5	Devices per reel	3000pcs
---------	---------	------------------	---------

Package dimension:

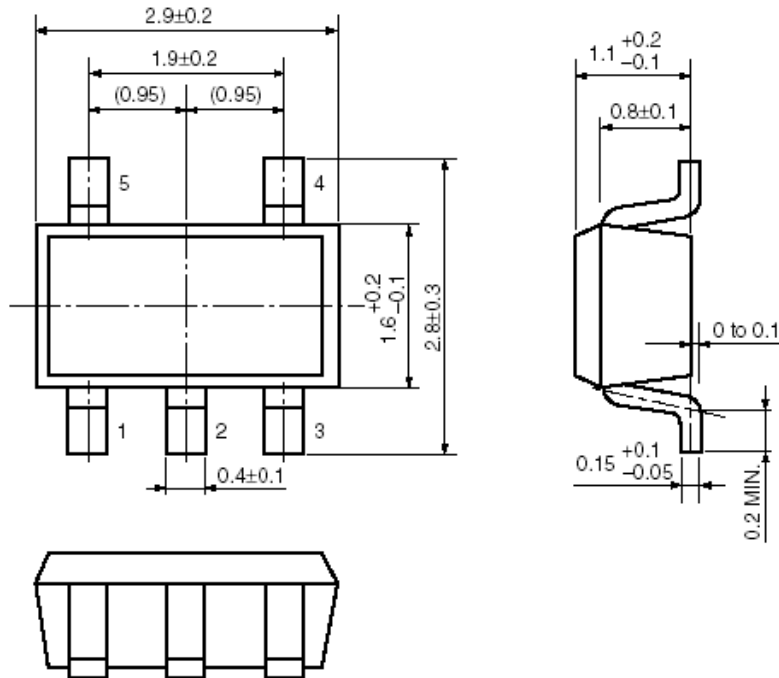

Unit: mm

Package	SOT-89-3	Devices per reel	1000pcs
---------	----------	------------------	---------

Package dimension:

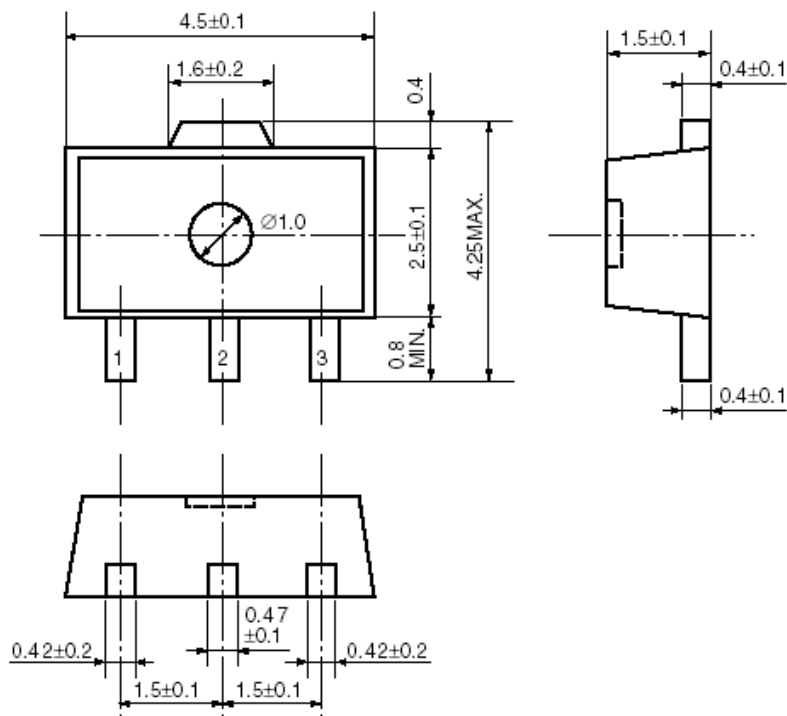

Unit: mm

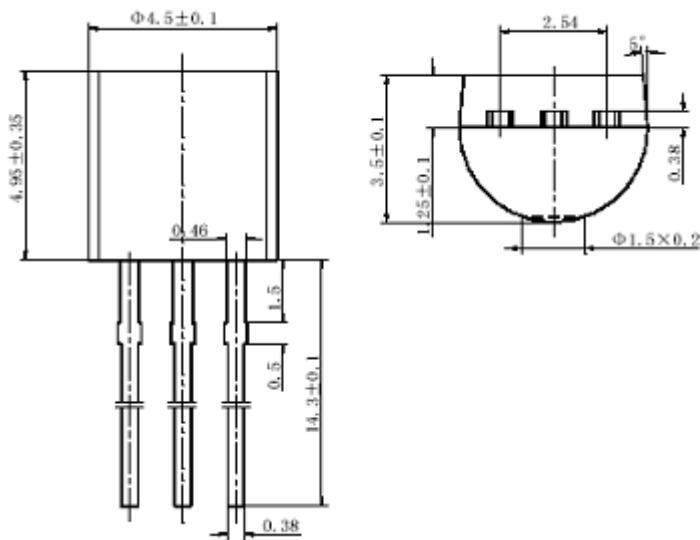
Package	TO-92	Devices per Bag	1000pcs
<p data-bbox="164 322 384 353">Package dimension:</p>  <p data-bbox="164 976 272 1003">Unit: mm</p> <p>The drawing shows two views of the TO-92 package. The left view is a side profile showing a cylindrical body with a diameter of $\Phi 4.5 \pm 0.1$ mm and a height of 4.95 ± 0.35 mm. The leads are spaced 0.46 mm apart. The lead length is 1.5 mm, and the lead diameter is 0.5 mm. The total length of the package including leads is 14.3 ± 0.1 mm. The bottom lead thickness is 0.38 mm. The right view is a top-down view of the package, showing a circular body with a diameter of $\Phi 1.5 \times 0.2$ mm. The lead spacing is 2.54 mm. The lead length is 3.5 ± 0.1 mm. The lead diameter is 0.38 mm. The lead angle is 5°. The distance from the center of the package to the lead tip is 1.25 ± 0.1 mm.</p>			